



OUTDOOR LINEAR 8 BURNER SYSTEM

Natural Gas









www.acucraft.com

888-317-6499



Complies with ANSI Z21.97-2014 / CSA 2.41-2014

 DANGER 	CARBON MONOXIDE HAZARD This appliance can produce carbon monoxide which has no odor. Using it in an enclosed space can kill you. Never use this appliance in an enclosed space as a camper, tent, car or home.	 WARNING Improper installation, adjustment, alteration, service, or maintenance can cause injury or property damage. Read the installation, operating and maintenance instructions thoroughly before installing or servicing this equipment.
 DANGER If you smell gas: 1. Shut off gas to appliance. 2. Extinguish any open flame. 3. If odor continues, keep away from the appliance and immediately call your gas supplier or fire department.		 WARNING Do not store or use gasoline or other flammable vapors and liquids in the vicinity of this or any other appliance. An LP-cylinder not connected for use shall not be stored in the vicinity of this or any other appliance.
 WARNING: For Outdoor Use Only		
INSTALLER: Leave this manual with the appliance. CONSUMER: Retain this manual for future reference.		

Installation/Operator's Manual

Rev5

TABLE OF CONTENTS

Introduction	pg 3
Safety / Warnings	pg 4
Installation Guide	
System Illustration	pg 5-9
Wiring Diagrams	pg 10
Connecting the Gas Valve & Ignition System	pg 11
Installing the Media	pg 12
Operation Guide	
Instructions	pg 13
Lighting Instructions.....	pg 14
Troubleshooting	pg 15-16
Caution	pg 17
Maintenance & Care	pg 18
Specifications	pg 19-20
Notes	pg 21
Warranty	pg 22

INTRODUCTION

Dedication to innovation, honesty, excellence, and hard work ensure that we can provide solutions to each and every one of our customers.

Our team stays up-to-date on all the latest trends and technologies to ensure we can provide customers with the perfect solution for their project. Our passion for excellence paves the way for our world-class products, systems & customer service. Our goal is to revolutionize the fireplace industry not by being the biggest, but by being the best. We push ourselves to do more than we think we are capable of. We are a family first organization, and we strive to be good stewards locally, nationally, and internationally.

Please review this manual carefully before installing your new fireplace.

Model: Outdoor Linear 8 Burner System (NG)



Acucraft Fireplaces
19672 172nd Street
Big Lake, MN 55309

www.acucraft.com 888-317-6499

SAFETY



WARNING

This appliance should be inspected before use and at least annually by a qualified service person. More frequent cleaning may be required as necessary. It is imperative that the control compartment, burners and circulating air passageways of the appliance be kept clean.



DANGER

Carbon monoxide poisoning may lead to death!

Carbon Monoxide Poisoning: Early signs of carbon monoxide poisoning resemble the flu, with headaches, dizziness, or nausea. If you have these signs, the system may not be working properly.

Get fresh air at once! Have the system serviced. Some people are more affected by carbon monoxide than others. These include pregnant women, people with heart or lung disease or anemia, those under the influence of alcohol, and those at high altitudes.

Natural Gas: Natural gas is odorless. An odor making agent is added to the gas. The odor helps you detect a gas leak. However, the odor added to the gas can fade. Gas may be present even though no odor exists.

Make certain you read and understand all warnings. Keep this manual for reference. It is your guide to safe and proper operation of this appliance.

HIGH ALTITUDE INSTALLATIONS:

The appliance is rated for installation up to 4500' (1372m) above sea level. Above 4500' the appliance must be de-rated at the factory for the appropriate altitude.

LOCAL CODES

Install and use the system with care. Follow local codes. In the absence of local codes, use the latest edition of *The National Fuel Gas Code ANSI Z223.1/NFPA 54* available from:

- American National Standards Institute Inc., 1430 Broadway, New York, NY 10018
- National Fire Protection Association Inc., Batterymarch Park, Quincy, MA 02269.



WARNING

Any change to this appliance or its controls can be dangerous.

1. This appliance, as supplied, is only for use with the type of gas indicated on the rating plate.
2. When an appliance is for connection to a fixed piping system, the installation must conform with local codes, or in the absence of local codes with the *National Fuel Gas Code, ANSI Z223.1/NFPA 54, or International Fuel Gas Code, Natural Gas Installation Code CSA B149.1.*
3. Keep the appliance area clear and free from combustible materials, gasoline and other flammable vapors and liquids.
4. Do not burn solid fuel in the fireplace after installing the appliance. Do not use this appliance to cook food or burn paper or other objects.
5. **Children and adults should be alerted to the hazards of high surface temperatures and should stay away to avoid burns or clothing ignition.**
6. **Clothing or other flammable materials should not be hung from the appliance, or placed on or near the appliance.**
7. **Young children should be carefully supervised when they are in the area of the appliance.**
8. The appliance, when installed, must be electrically grounded in accordance with local codes or, in the absence of local codes, with the *National Electrical Code, ANSI/NFPA 70*, if applicable.
9. **Do not use appliance if any part has been under water. Immediately call a qualified service technician to inspect the room appliance and to replace any part of the control system and any gas control which has been under water.**
10. Inspect the burner before each use of the system. The burner must be replaced prior to the appliance being put into operation if it is evident that the burner is damaged. For replacement please contact Acucraft at: 763-263-3156 or service@acucraft.com.
11. Turn the appliance off and let cool before servicing, installing, or repairing. **Any guard or other protective device removed for servicing the appliance must be replaced prior to operating the appliance.** Only a qualified service person should install, service, or repair the appliance.

INSTALLATION GUIDE

Note: The installation of this product must conform with local codes or, in the absence of local codes, the current **National Fuel Gas Code - ANZI Z223.1 (NFPA 54)** Installation Code. Please check local codes before installation.

NOTE TO INSTALLER:

1. This appliance is for **OUTDOOR USE ONLY**. **DO NOT** install or use this appliance inside a building, garage or any other enclosed area, including recreational vehicles and/or boats. **This unit must be installed in such a manner that the combustion air intake at the base of the unit remains clear and free of all obstructions at all times and during all weather conditions.**
2. **FOR NATURAL GAS:** The minimum inlet pressure is 0.25 psi and the maximum inlet gas-supply pressure is 2.0 psi. The normal operating inlet pressure is 7" WC. **DO NOT INSTALL THIS UNIT IF MINIMUM PRESSURE IS NOT AVAILABLE OR IF MAXIMUM PRESSURE IS EXCEEDED.**
3. Gas piping system must be sized to provide minimum inlet pressure at the maximum flow rate (BTU/hr). 45,000 to 60,000 BTU's based on the desired flame height. Undue pressure loss will occur if the pipe is too small, or the run is too long.
4. The appliance and its appliance main gas valve must be disconnected from the gas supply piping system during any pressure testing of that system at test pressures in excess of 1/2 psi (3.5 k/Pa). The appliance must be isolated from the gas valve supply piping system by closing the equipment shutoff valve during any pressure testing of the gas supply piping system at test pressures equal to or less than 1/2 psi (3.5 k/Pa).



WARNING

If the information in these instructions is not followed exactly, a fire or explosion may result causing property damage, personal injury or loss of life.

- Do not store or use gasoline or other flammable vapors and liquids in the vicinity of this or any other appliance.
- **WHAT TO DO IF YOU SMELL GAS**
 - Do not try to light any appliance
 - Do not touch any electrical switch; do not use any phone in your building
 - Immediately call gas supplier from a neighbor's phone. Follow the gas supplier's instructions.
 - If you cannot reach your gas supplier, call the fire department.
- Installation and service must be performed by a qualified installer, service agency or the gas supplier.

INSTALLATION GUIDE

INSTALLATION SAFETY GUIDELINES

1. Installation and repair should be done by a qualified service person. The appliance should be inspected before use and at least annually by a qualified service person. More frequent cleaning may be required as necessary. It is imperative that the control compartment, burners and circulating air passageways of the appliance be kept clean.
2. Carefully inspect for shipping damage. If any parts are damaged, call Acucraft at 763-263-3156.
3. Correct installation and proper placement of the unit and decorative media is crucial to safe performance of the unit. See installation instructions for further information.
4. A listed manual gas shutoff device must be installed prior to the location of the fireplace.

TO INSTALL THE BURNER

The installation of this appliance must conform with local codes or, in the absence of local codes, with the *National Fuel Gas code, ANSI Z223.1/NFPA54*, or the *Natural Gas and Propane Installation Code, CSA B149.1*.

Final assembly of this fireplace on site consists of the following main steps:

1. Positioning and securing of the fire pit
2. Connecting the gas valve and ignition system
3. Installing fireplace media and fireplace glass panes, if applicable

POSITIONING THE FIREPLACE

- The burner is designed to sit directly on non-combustible materials
- Identify the location of the fire pit
- Set the burner over the incoming gas line

Note: The appliance should be positioned in a manner that planned gas line access is available with adequate clearance for servicing from the top of the fire pit.

Clearances must be in accordance with local installation codes and requirements of the gas supplier.

INSTALLATION GUIDE

GAS INFORMATION

Fuel - Before making gas connections ensure appliance being installed is compatible with the available gas type.

Gas Pressure - Proper Input Pressures are required for optimum appliance performance. Gas line sizing requirements need to be made following NFPA51.

Pressure Requirements for Appliance (Natural Gas)

Minimum Inlet Pressure: 0.25 psi

Nominal Operating Inlet Pressure: 7" WC (NG)

Maximum Inlet Pressure: 2.0 psi

Gas Connection - Have the gas supply line installed in accordance with local building codes, if any. If not, follow ANSI 223.1. Installation should be done by a qualified installer approved and/or licensed as required by locality.

Note: A listed manual gas shutoff device must be installed prior to the location of the appliance.

Startup - A small amount of air will be in the gas supply lines. When first lighting appliance it will take a short time for air to purge from the lines. Subsequent lighting of the appliance will not require such purging.



WARNING

Check for Gas Leaks after installation complete

- Check all fittings and connections
- Do not use open flame to check for leaks
- Check for leaks with a commercially available, non-corrosive leak check solution

Electrical Information

Note: The 24 volt transformer supplied is to be located in a remote location away from the fire feature in an approved weatherproof electrical junction box and installed in accordance with local codes.

Recommended Wire Size

No less than 12 gauge wire for all installations

Note: There are numerous electrical devices that can be used to turn the fire feature on and off. Devices such as wall switches and remote control devices that are used should be UL listed and approved devices for turning high voltage (110 v electrical power) on and off. This high voltage electrical power shall be connected to the supplied 24 volt AC transformer by a qualified electrical installer.

INSTALLATION GUIDE

Installation – Natural Gas

Note: Installation should be done by a qualified service technician that is locally licensed.

1. In the photo at right there is a bowl with both a gas riser and an electrical conduit stubbed up inside the bowl. In this photo the gas riser is centered whereas the electrical is off center. It is preferred to stub the gas riser centered in order to ensure the fire ring is centered in the bowl once installation is complete.

NOTE: Drainage **MUST** be provided in the bottom of the bowl. Drainage can be obtained by making a simple hole as shown at right or providing a drain line next to the gas and electrical conduit.

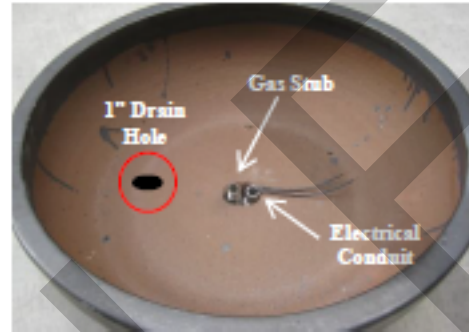

2. Apply pipe dope to the gas stub and thread the AWEIS onto the gas riser as shown in the photo at right.

NOTE: Leak Test – it is highly recommended to perform a gas leak test at this point in the install. Turn on the gas supply and then, using a soapy water solution spray the bottom of the AWEIS where it is connected to the gas line to ensure no leaks exist.

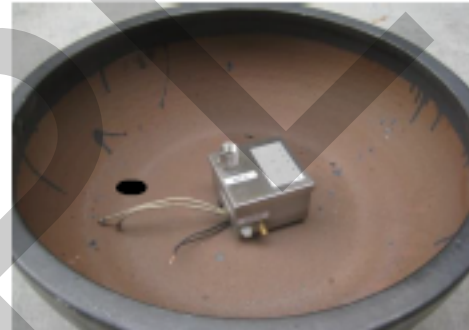

3. Electrical Connections / Orifice Install. In the photo at right the wires protruding from the AWEIS have been connected to the two wires from the electrical conduit using appropriate sized wire nuts.

In addition a short pipe nipple and the Natural Gas Orifice (supplied) are installed using either Teflon tape or gas plumbing pipe dope.



4. On the side of the AWEIS there are two connections for the Pilot Burner Assembly as shown in the photo at right. The white 'quick connect' is the electrical connection and the brass plumbing fitting is the gas connection. There is a label next to these connections, "Attach Pilot Burner Here".



5. The photo at right shows the AWEIS after the Pilot Burner Assembly has been connected.

NOTE: The electrical connection for the Pilot Burner Assembly is a shaped connection thereby ensuring it can only be connected the correct way. On the Pilot Burner Assembly side of the connection there is a locking clip on the quick connect that will 'lock' the connection in place. Therefore after making the connection lightly tug on the connection to ensure it is in fact 'locked' in place.



INSTALLATION GUIDE

6. Install the Heat Deflector Shield. Notice the heat shield has a notch on one side. Position the Pilot Burner in the notch **ONLY** when using either a 6" or 18" fire ring. For all other burner sizes attach the Pilot Burner to the heat shield on the opposite side of the notch as shown in photo at right. Use the two screws that came with the heat shield to attach the Pilot Burner to the heat shield.



7. Install Fire Ring using either Teflon tape or gas plumbing pipe dope. Holes in the Fire Ring **MUST FACE UP**.



SAMPLE

INSTALLATION GUIDE

Attachment 1 Automated Pool Controller Wiring

**Wiring When
2 Fire Features
Turned On & Off
with One Button**

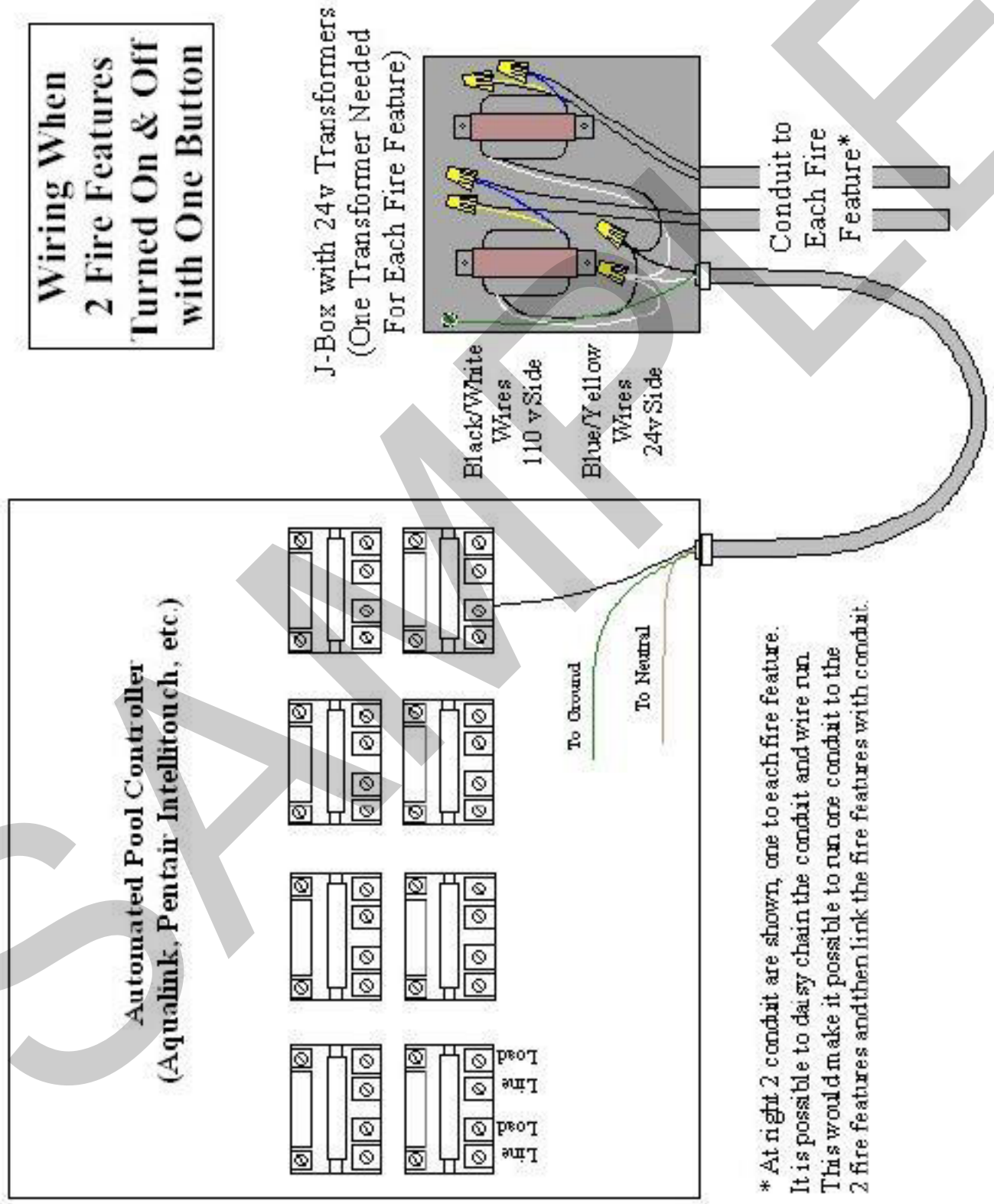

* At night 2 conduit are shown, one to each fire feature. It is possible to daisy chain the conduit and wire run. This would make it possible to run one conduit to the 2 fire features and then link the fire features with conduit.

INSTALLATION GUIDE



Control Box

Connection of the ignition system to the burner. On the side of the AWEIS there are two connections for the pilot burner assembly. The white “quick connect” is the electrical connection and the brass plumbing fitting is the gas connection. There is a label next to these connections, “Attached Pilot Burner Here.”

Connection of the wiring harness/pilot tubing extension is shown to the bottom of the igniter.

Pilot Assembly Mount

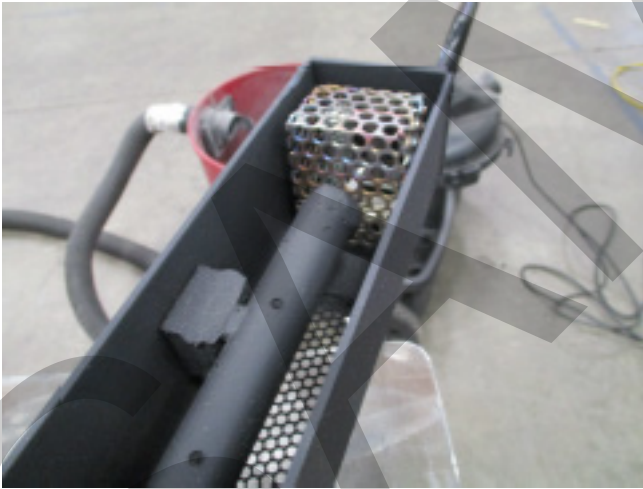

INSTALLATION GUIDE

Installation of fireplace media and glass panels:

This fireplace burner requires a layer of 1/4" glass media to cover the burner tube, allowing proper dissipation of the gas flow and propagation of the flame. This should be spread evenly across and completely covering the burner located inside of the square burner tray.

Carefully place the glass media over the top of the burner and mesh media tray located inside of the square burner tray, allowing glass to fill void alongside tube and to cover over the top of the tube with approximately 1/4" of the 1/4" glass media.



The photo to the left shows the finished look that should be achieved with the glass media over the burner.

INSTALLATION GUIDE

OPERATING INSTRUCTIONS



WARNING

Do NOT use this appliance if any part has been under water. Immediately call a qualified service technician to inspect the appliance and to replace any part of the control system and any gas control which has been under water.



WARNING

Fire Risk / Burn Risk / HOT! DO NOT TOUCH
SEVERE BURNS MAY RESULT - CLOTHING IGNITION MAY RESULT

- Keep children away.
- CAREFULLY SUPERVISE children in the same area as the appliance.
- Alert children and adults to hazards of high temperatures.
- Clothing or other flammable materials should not be hung from the appliance or placed on or near the appliance.



WARNING

This appliance should be inspected before use and at least annually by a qualified service person. More frequent cleaning may be required as necessary. It is imperative that control compartment, burners and circulating air passageways of the appliance be kept clean.



CAUTION

It is NOT recommended outdoor fire features be operated when wind exceeds 25 mph.

INSTALLATION GUIDE

LIGHTING INSTRUCTIONS

1. Prior to turning appliance on, visually inspect fire feature to ensure debris such as leaves or other combustible material has not collected inside the feature which could burn and emit embers once the fire feature is turned on. Also ensure any person standing close to the fire feature is aware that you will be turning the fire feature on prior to actually turning it on.
2. Turn the fire feature on by turning on the electrical device used to power the fire feature:
 - Sequence of Operation during Ignition:
 - Power is applied
 - Hot Surface Igniter (Glow Plug) becomes hot and Pilot Gas Valve opens
 - Within 10 seconds of power application Pilot Flame should be visible (at night only)
 - Within 10 seconds of Pilot Flame Ignition burner element (fire ring/burner bar) should ignite
3. Turn fire feature off by turning off the electrical device used to power the fire feature.

INSTALLATION GUIDE

TROUBLESHOOTING

Q: I installed the Electronic Ignition System, turned it on and nothing happened.

A: When this occurs it is usually due to an electrical wiring/power issue. Check all your electrical connections thoroughly to ensure all wires at the transformer and inside the fire feature are connected properly. If it appears all wiring is connected properly, disconnect the wires at the fire feature, attach a Multi-meter to the wires to confirm a minimum of 24 volts when the fire feature is turned on. If you determine that you do not have a minimum of 24 volts at the fire feature conduct the same test at the transformer to ensure the transformer is in fact producing a minimum of 24 volts. If you do have a minimum of 24 volts at the fire feature contact Acucraft for further assistance: 763-263-3156.

Q: I installed the Electronic Ignition System, turned it on and I can see the glow plug glowing orange and I can hear gas flowing but it will not ignite.

A: There are two possible causes to this problem: Air in the Gas Line or not enough Electrical Current to the fire feature.

Air in the Gas Line. If a new gas line was installed and the air was never purged from it prior to installing the Electronic Ignition System then it may take several times of turning the fire feature on and off before the air is purged from the gas line. Here is how our system works: after you turn it on the glow plug will come on first followed by the Pilot Gas Valve opening 4 seconds later. For the next 180 seconds (3 minutes) the glow plug will cycle on and off every 30 seconds while the Pilot Gas Valve will remain on the entire time. Therefore if you are attempting to purge air from the gas line, turn the system on and leave it on for approximately 3 minutes. Usually when purging air from a new gas line you will need to cycle the power several times as described above before gas begins to flow. If at any point you smell gas but still don't have ignition, attempt to light the Pilot flame with a handheld lighter. If the flame ignites when you light it by hand, go to the section below: "Electrical Current."

Electrical Current. If you have determined that air in the gas line is not the problem then most likely the failure to ignite is due to the fact that the glow plug is not getting hot enough to ignite the gas. The reason a glow plug will not get hot enough is due to the fact that it is not getting enough 'amps.' Often times when troubleshooting electricians will check the electrical power and when they see they have a minimum of 24 volts they think everything is fine electrically so there must be a problem with the Electronic Ignition System. The problem is not due to the volts but rather the amps. The number of amps reaching the fire feature is heavily dependent on the gauge wire used between the transformer and the fire feature. Our Install Instructions require no less than 12 gauge wire be run for all fire features. Often times we learn that in many cases less than 12 gauge wire has been used and herein lies the cause of the problem. *(Continued on next page)*

INSTALLATION GUIDE

TROUBLESHOOTING

1. CAUTION. Turn off the gas supply prior to the next step.
2. Using a clamp on the ammeter, clamp the ammeter around one of the wires providing power to the Electronic Ignition System.
3. Turn the fire feature on.
4. The amps you should see will range between 1.4 to 1.6 amps initially. Four seconds after being turned on the amps will jump to approximately 2.0 amps.

If you do not see the amps listed above AND the wire gauge used was less than 12 gauge wire - change the wiring. Otherwise contact Acucraft for further assistance: 763-263-3156.

INSTALLATION GUIDE

CAUTION

- Due to high temperatures, the appliance should be located out of traffic and away from furniture and draperies
- Children and adults should be alerted to the hazards of high surface temperatures and should stay away to avoid burns or clothing ignition
- Young children should be carefully supervised when they are in the same room as the appliance. Toddlers, young children and others may be susceptible to accidental contact burns. A physical barrier is recommended if there are at-risk individuals in the house. To restrict access to a fireplace or stove, install an adjustable safety gate to keep toddlers, young children and other at-risk individuals out of the room and away from hot surfaces
- Clothing or other flammable material should not be placed on or near the appliance
- Installation and repair should be done by a qualified service person. The appliance should be inspected before use and at least annually by a professional service person. More frequent cleaning may be required due to excessive lint from carpeting, bedding material, etc. It is imperative that control compartments, burners, and circulating air passageways of the appliance be kept clean
- Do not use this appliance if any part has been under water. Immediately call a qualified service technician to inspect the appliance and to replace any part of the control system and any gas control which has been under water
- This appliance is only intended for operation in temperatures above 32° F
- When shutting the unit down - be sure to TURN THE CONTROL VALVE FULLY OFF
- Every time you use the unit, make sure that:
 - The area around the unit is clear and free from combustible materials, gasoline and other flammable vapors and liquids
 - There is no blockage of the airflow through the vent openings
- **WARNING: HOT WHILE IN OPERATION AND FOLLOWING OPERATION. Serious injury can occur! DO NOT** throw trash, paper, or other flammable materials onto the unit. **DO NOT** leave in operation when unattended

INSTALLATION GUIDE

MAINTENANCE AND GENERAL CARE

- Examination and inspection of the appliance and all components including the burner, should be performed annually by a qualified service technician
- Examination and visual check of the burner & flame should be performed periodically to ensure proper operation
- Replacement of worn, broken, or non-functioning components should be left to a qualified service technician
- If glass panels suffer any type of impact, immediately cease use of fire pit until a qualified technician can assess the integrity of the panels and determine if they need replacement before continued use
- The area around the appliance must be kept clear and free from combustible materials, gasoline, and other flammable vapors and liquids
- The unit should be inspected regularly. Excessive debris can build up on this unit from leaves, dirt, or other debris. It is critical that all control components, burners, burner screen and vent opening be kept clean and free of all obstructions.



WARNING

- Follow lighting instructions provided in this manual.
- Never use abrasive cleaners to clean the glass.
- Do not clean appliance when hot.
- Clean the tempered glass with a basic household glass cleaner. Never use glass cleaner that contains ammonia, as it may etch the tempered glass.

PRODUCT SPECIFICATIONS

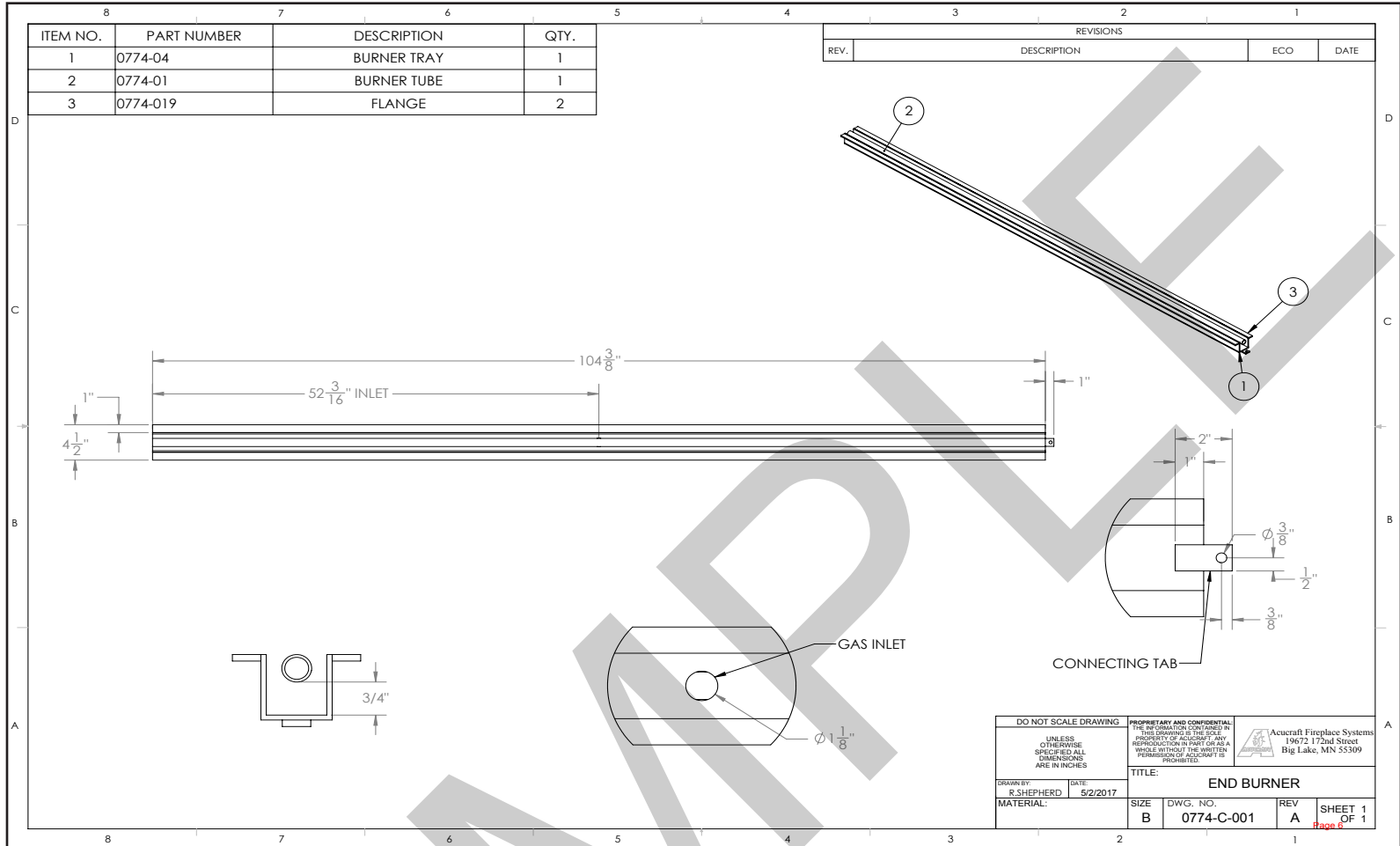

SPECIFICATIONS

Depth = 2 1/2"
 Length = 138 1/2"
 Width = 4 1/2"
 Appx Weight. = 200 lbs.
 Gas Type = Natural Gas
 Electrical = Single 15 AMP service

NATURAL GAS
 Input Rating (BTU/hr) 0-1370 m = 125,000 BTUs/hr.
 Minimum inlet pressure (in.w.c.) = 7.0 in. W.C.
 Maximum inlet pressure (in.w.c.) = 10.5 in. W.C.

Based on testing that was performed, the following results have been recorded.
 Minimum Clearances to combustibles
 Unit to back wall of enclosure = 4 feet
 Unit to sidewall of enclosure = 4 feet
 Unit top to enclosure top = 8 feet

PRODUCT SPECIFICATIONS

MANUFACTURER: OUTDOOR DECORATIVE GAS APPLIANCE		Serial #/En Série: 0774-C-001
Acucraft Fireplaces MODEL/ MODELE: Outdoor Linear 8 Burner System 19672 172nd St Big Lake, MN 55309 (763) 263-3156		
GAS / TYPE DE GAZ:		Natural Gas (Gaz naturel)
INPUT RATING (ENTRÉE NOTE) (Btu/hr) 0-610m:		125,000
ORIFICE SIZE (DIMENSIONS DE L'ORIFICE) (DMS) 0-610m:		P
INPUT RATING (ENTRÉE NOTE) (Btu/hr) 610-1370m:		125,000
ORIFICE SIZE (DIMENSIONS DE L'ORIFICE) (DMS) 610-1370m:		$5/16$
MANIFOLD PRESSURE (PRESSION D'ADMISSION) (in. wc/kPa):		3.5/(0.9)
MINIMUM INLET PRESSURE (MINIMUM PRESSION D'ENTRÉE) (in. wc/kPa): 7.0/(1.74)		
<p>For Outdoor Use Only. If Stored Indoors, Detach and Leave Cylinder Outdoors. Pour utilisation à l'extérieur seulement. Si l'appareil est entreposé à l'intérieur enlever les bouteilles et les laisser à l'extérieur.</p>		
Follow installation instruction. Suivez les instructions d'installation.	Minimum clearances to combustibles:	Unit to back wall of enclosure: 4 feet Unit to sidewall of enclosure: 4 feet Unit top to enclosure cap: 8 feet
CERTIFIED FOR CANADA/ CERTIFIÉ POUR LE CANADA ANSI Z21.97, CSA 2.41-2014		Lab Test
<p style="text-align: center;">DO NOT REMOVE THIS LABEL N'ENLEVEZ PAS CETTE ETIQUETTE</p>		

NOTES

SAMPLE

WARRANTY

ALL WARRANTIES EFFECTIVE DATE OF SHIPMENTS

The Warranty

Acucraft warrants the gas appliance to be free from defects in materials and workmanship at the time of manufacture. On all gas appliances, there is a **lifetime warranty** on the firebox. There is a **five-year warranty** on the main burner. A **one-year warranty** is given to the pilot burner, gas control valve, glass media and logs, and other gas components.

No Warranty

Acucraft does not warrant any finish or plating on the system or any part thereof. Glass and refractory lining are exempt from warranty as well.

Remedy and Exclusions

The coverage of this warranty is limited to all components of the gas appliance manufactured by Acucraft. If the components of the gas appliance covered by this warranty are found to be defective within the time stated. Acucraft, at its option, will replace or repair defective components of the gas appliance manufactured by Acucraft at no charge, and may also choose pay for reasonable labor costs incurred in repairing components requiring approval prior to work commencing. This warranty covers only parts and labor as provided above. In no case shall Acucraft be responsible for materials, components, or construction which are not manufactured or supplied by Acucraft, or for the labor necessary to install, repair or remove such materials, components or construction. All replacement or repair components will be shipped F.O.B. back to Acucraft. A warranty credit will be issued upon receipt and testing of defective parts.

Qualifications to the Warranty

The gas appliance warranty outlined above is further subject to the following qualifications:

- (1) The gas appliance must be installed in accordance with Acucraft installation instructions and local building codes. The warranty on this Acucraft gas appliance covers only the component parts manufactured by Acucraft. The use of components manufactured by others with the Acucraft gas appliance could create serious safety hazards, and may result in the denial of certification by recognized national safety agencies, and could be in violation of local building codes. This warranty does not cover any damages occurring from the use of any components not manufactured or supplied by Acucraft.
- (2) The Acucraft gas appliance must be subjected to normal use. The gas appliances are designed to burn gas only. Burning conventional fireplace fuels such as wood, coal or any other solid fuel will cause damage to the gas appliance, will produce excessive temperatures and will result in a fire hazard.

Limitations on Liability

It is expressly agreed and understood that Acucraft's sole obligation, and purchaser's exclusive remedy under this warranty, under any other warranty, expressed or implied, or in contract, tort or otherwise, shall be limited to replacement, repair, or refund, as specified above.

In no event shall Acucraft be responsible for any incidental or consequential damages caused by defect in its products, whether such damage occurs or is discovered before or after replacement or repair, and whether or not such damage is caused by Acucraft negligence. Some states do not allow the exclusion or limitation of incidental or consequential damages, so the above limitation or exclusion may not apply to you. The duration or any implied warranty with respect to this Acucraft gas appliance is limited to the duration of the foregoing warranty. Some states do not allow limitation on how long an implied warranty lasts, so the above may not apply to you.

Investigation of Claims against Warranty

- Acucraft reserves the right to investigate any and all claims against this warranty and to decide upon method of settlement.
- Acucraft is not responsible for work done without consent.
- Acucraft shall in no event be responsible for any warranty work done without first obtaining Acucraft's written consent.
- Resellers have no authority to alter this warranty.
- Acucraft employees and resellers have no authority to make any warranties nor to authorize any remedies in addition to or inconsistent with those stated above.

How to Register a Claim against Warranty

In order for any claim under this warranty to be valid, Acucraft must be notified of the claimed defect by emailing service@acucraft.com, as soon as reasonably possible after the defect is discovered. Claims against this warranty must include the date of installation, and a description of the defect.

In order to validate your warranty you must complete the warranty form at www.acucraft.com/warranty within thirty (30) days of receiving your fireplace. Without a warranty validation you will not be able to submit any warranty claims for your Acucraft appliance.

SAMPLE



FIRE IS OUR PASSION

www.acucraft.com 888-317-6499

Acucraft Fireplaces
19672 172nd Street
Big Lake, MN 55309