

8 7 6 5 4 3 2 1

REVISIONS			
REV.	DESCRIPTION	ECO	DATE
A	INITIAL RELEASE	AR	12/19/2017
B	STRUCTURAL BEAMS AND MOUNTS ADDED	RS	1/4/2018
C	HOOD DIMS ADJUSTED; DUCTING ADJUSTED	RS	1/16/2018
D	INTAKES MOVED TO SAME SIDE OF UNIT	RS	1/19/2018
E	TUBE STEEL TRIM ADJUSTMENT MADE	RS	1/26/2018
F	TUBE STEEL TRIM ADJUSTMENT MADE	RS	1/29/2018
G	HEIGHTS ADJUSTED FOR HEARTH HEIGHT AND ANCHOR BOLTS	RS	2/15/2018
H	BOTTOM ADJUSTED TO ALLOW HEARTH TO COME TO DESIRED HEIGHT.	RS	2/19/2018

D
C
B
A

D
C
B
A

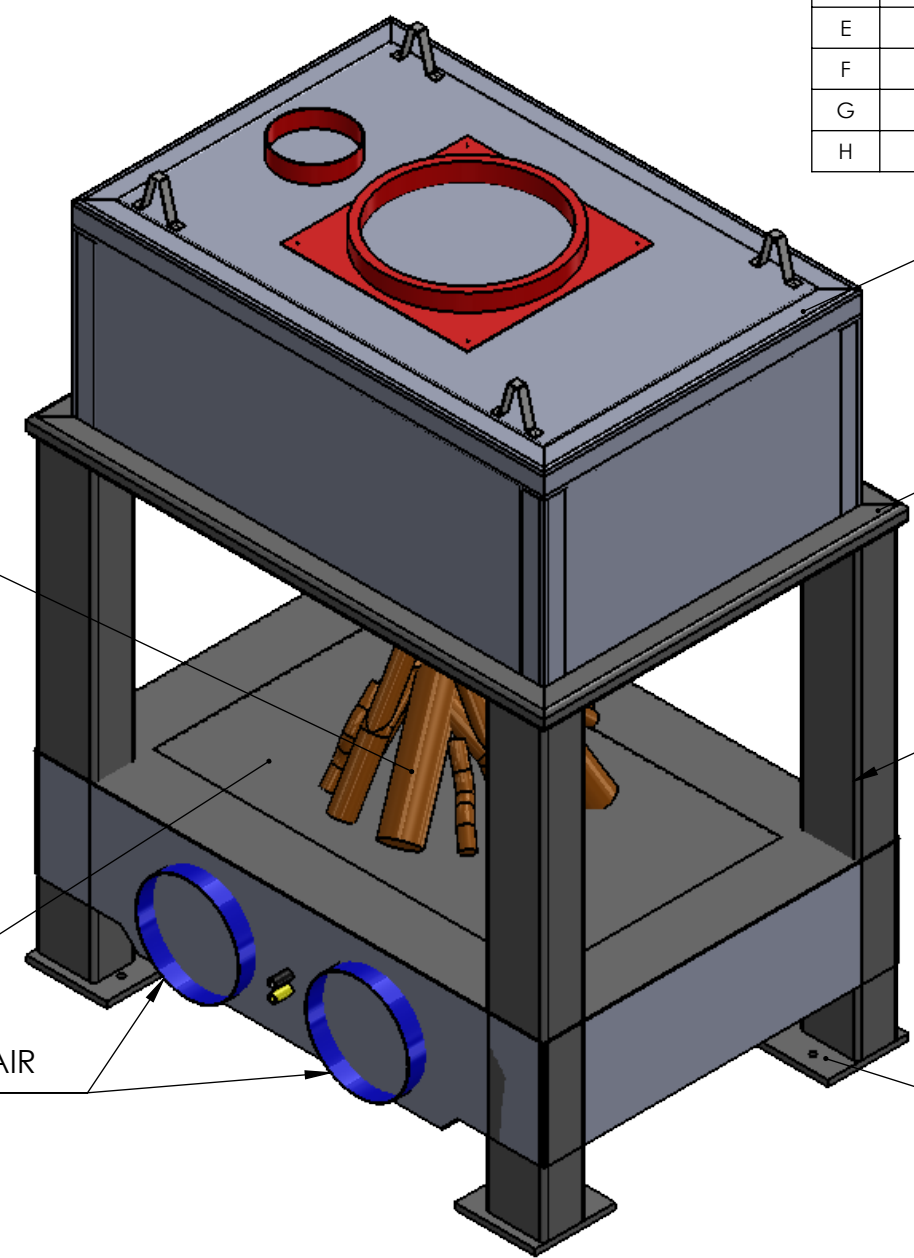

- CAMPFIRE STYLE LOGSEET
- MESH TO BE COVERED WITH LAVA ROCK
- DUAL 12" COMBUSTION AIR INTAKE WITH INLINE FANS
- 3"x3" TUBE STEEL PERIMETER AROUND TOP
STEEL STUD TRACK TO BE WELDED TO BE WELDED TOP OF PERIMETER, BY OTHERS
- 2" x 10" TUBE STEEL TRIM, DIMS TBD
- 5X7 RECTANGULAR TUBE TYP
- 9 1/2" X 9 1/2" X 3/4" BEARING PLATE

CHECKED BY: _____

CHECKED BY: _____

DO NOT SCALE DRAWING		<small>PROPRIETARY AND CONFIDENTIAL: THE INFORMATION CONTAINED IN THIS DRAWING IS THE SOLE PROPERTY OF ACUCRAFT. ANY REPRODUCTION IN PART OR AS A WHOLE WITHOUT THE WRITTEN PERMISSION OF ACUCRAFT IS PROHIBITED.</small>		 Acucraft Fireplace Systems 19672 172nd Street Big Lake, MN 55309
UNLESS OTHERWISE SPECIFIED ALL DIMENSIONS ARE IN INCHES		TITLE: CUSTOM 4-SIDED INDOOR JM SWAN CONSTRUCTION		
DRAWN BY: R.SHEPHERD	DATE: 12/19/17	SIZE B	DWG. NO. 7093-A-009	REV H
MATERIAL:				SHEET 1 OF 2

8 7 6 5 4 3 2 1

DETAIL C
SCALE 1 : 4

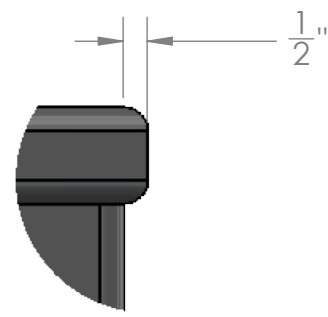

DETAIL D
SCALE 1 : 12

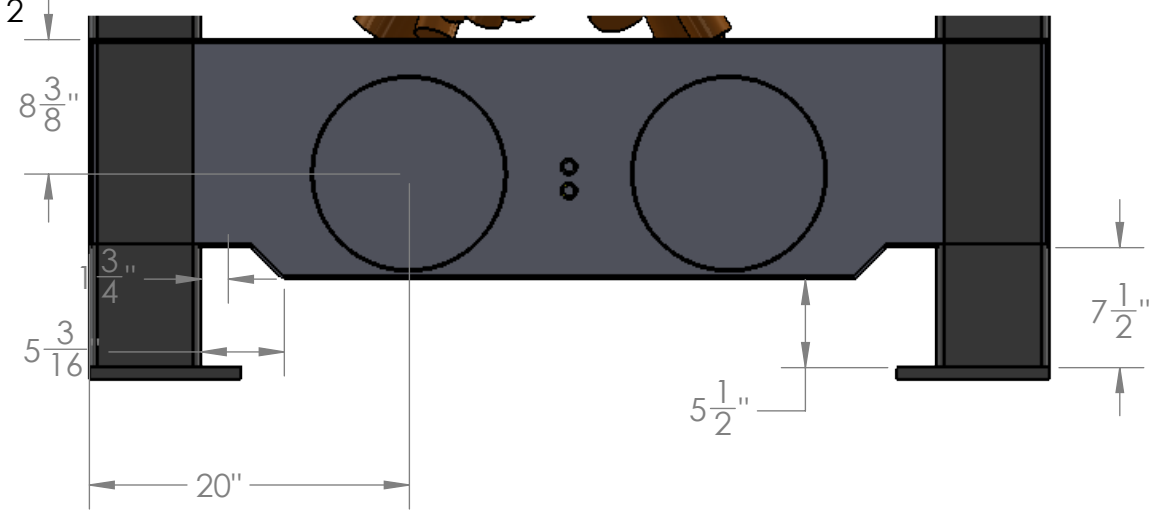

Ø8" B-VENT FOR HEAT RELIEF Ø18" CLASS A FLUE

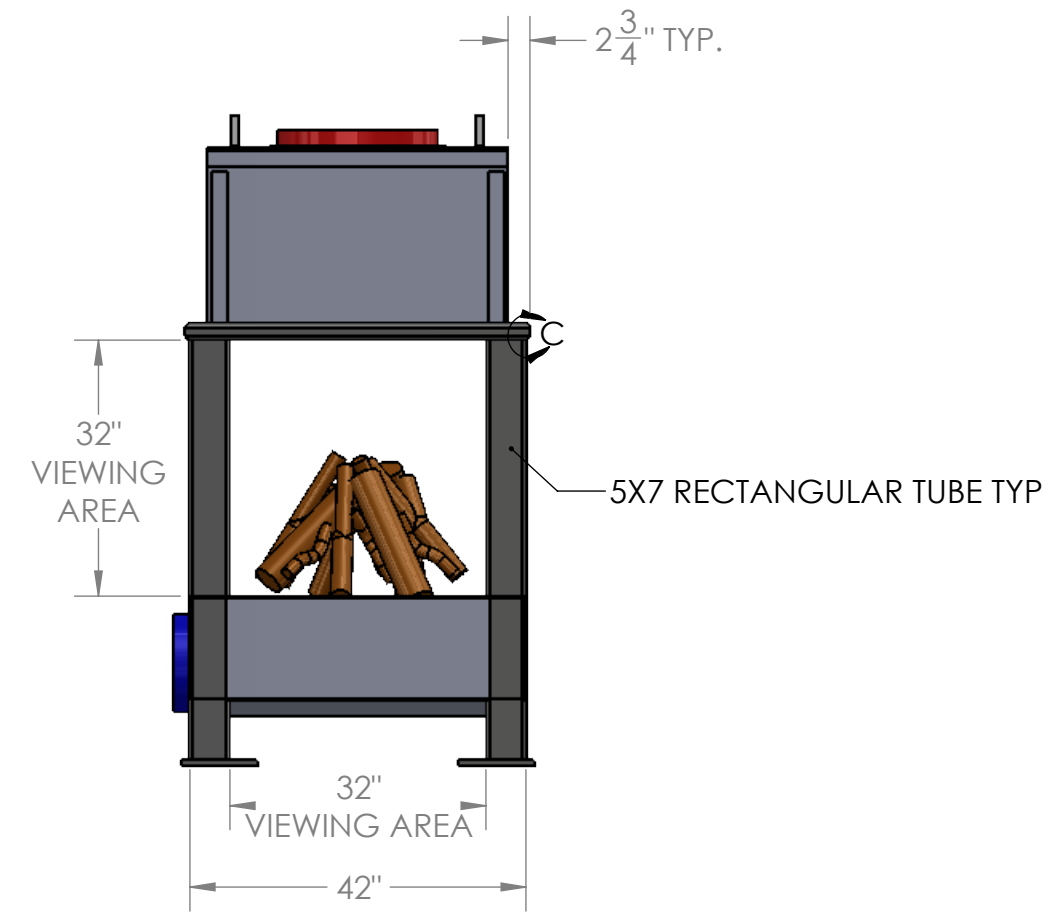
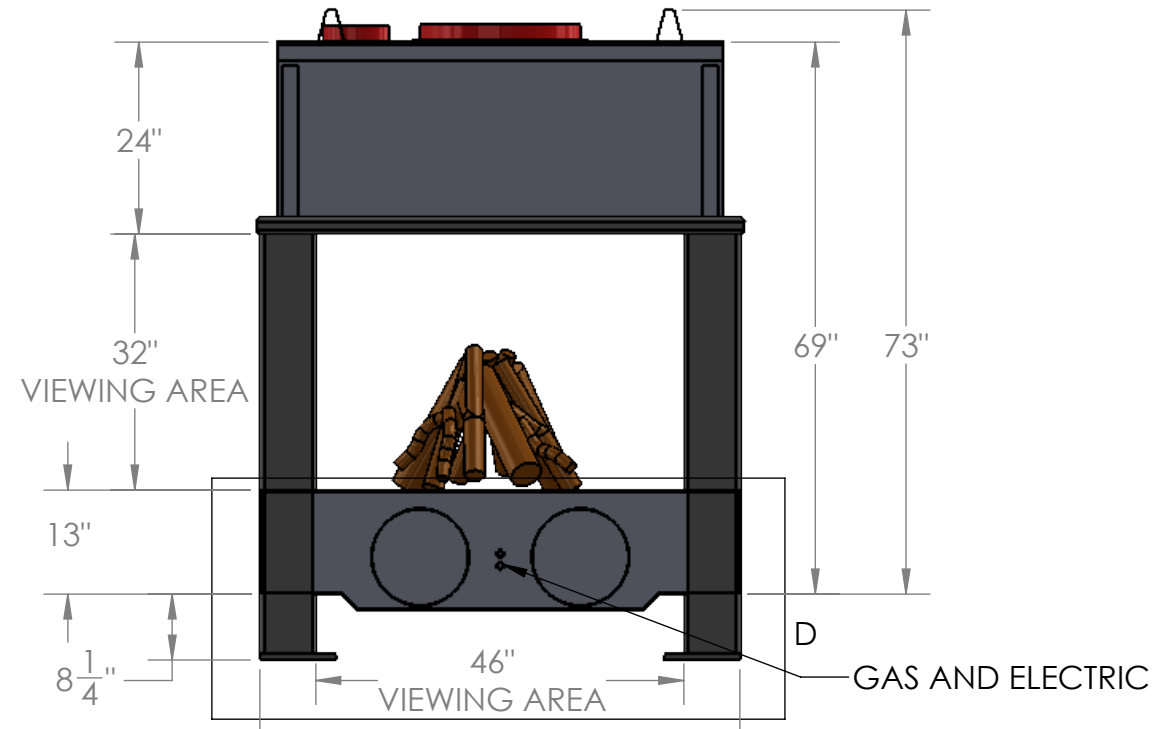

DUAL 12" COMBUSTION
AIR INTAKE WITH INLINE FANS

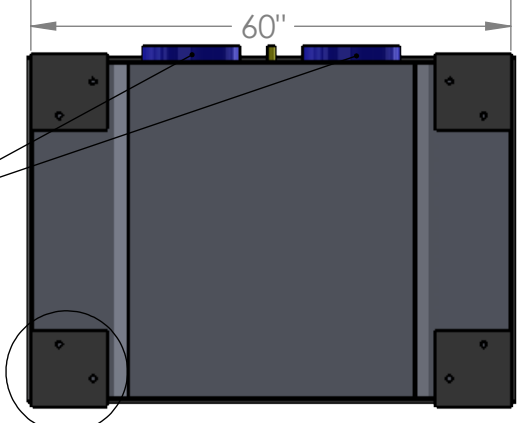

BEARING PLATE DETAIL

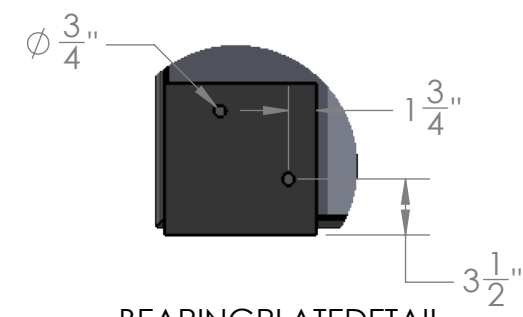

BEARING PLATE DETAIL
SCALE 1 : 12

DO NOT SCALE DRAWING		PROPRIETARY AND CONFIDENTIAL: THE INFORMATION CONTAINED IN THIS DRAWING IS THE SOLE PROPERTY OF ACUCRAFT. ANY REPRODUCTION IN PART OR AS A WHOLE WITHOUT THE WRITTEN PERMISSION OF ACUCRAFT IS PROHIBITED.		 Acucraft Fireplace Systems 19672 172nd Street Big Lake, MN 55309
UNLESS OTHERWISE SPECIFIED ALL DIMENSIONS ARE IN INCHES		TITLE: CUSTOM 4-SIDED INDOOR JM SWAN CONSTRUCTION		
DRAWN BY: R.SHEPHERD	DATE: 12/19/17	SIZE B	DWG. NO. 7093-A-009	REV H
MATERIAL:		SHEET 2 OF 2		