



Acucraft Custom Gas 44 Fireplace with Logs

Serial #: 6675



This is a vented decorative gas appliance: not a source of heat; not for use with solid fuel.

WARNING:

FIRE OR EXPLOSION HAZARD

Failure to follow safety warnings exactly could result in serious injury, death, or property damage.

- Do not store or use gasoline or other flammable vapors and liquids in the vicinity of this or any other appliance.

- WHAT TO DO IF YOU SMELL GAS

- Do not try to light any appliance.
- Do not touch any electrical switch; do not use any phone in your building.
- Leave the building immediately.
- Immediately call your gas supplier from a neighbor's phone. Follow the gas supplier's instructions.
- If you cannot reach your gas supplier, call the fire department.

- Installation and service must be performed by a qualified installer, service agency or the gas supplier.

INSTALLER: Leave this manual with the appliance.

CONSUMER: Retain this manual for future reference

www.acucraft.com

888-317-6499

Installation/Operator's Manual

Rev.4

TABLE OF CONTENTS

Introduction	pg 3
Safety / Warnings	pg 4
Installation Guide	
System Illustration	pg 11
Wiring Diagrams	pg 12
Positioning the Fireplace	pg 13
Installing the Ventilation System	pg 14
Connecting the Gas Valve & Ignition System	pg 17
Installing the Log Set.....	pg 18
Custom Gas Components	
Component Quick Reference Guide & Replacement Parts...	pg 22
Draft Controller	pg 23
Gas Valve & Ignition Module	pg 26
Draft Switch	pg 31
Inline Fan	pg 33
Chimney Fan	pg 34
Notes	pg 40
Operation Guide	
Specifications	pg 41
Operation Guide	pg 44
Troubleshooting	pg 46
Maintenance & Care	pg 47
Notes	pg 48
Warranty	pg 49

INTRODUCTION

Dedication to innovation, honesty, excellence, and hard work ensure that we can provide solutions to each and every one of our customers.

Our team stays up-to-date on all the latest trends and technologies to ensure we can provide customers with the perfect solution for their project. Our passion for excellence paves the way for our world-class products, systems & customer service. Our goal is to revolutionize the fireplace industry not by being the biggest, but by being the best. We push ourselves to do more than we think we are capable of. We are a family first organization, and we strive to be good stewards locally, nationally, and internationally.

Please review this manual carefully before installing your new fireplace.

Acucraft Custom Gas 44 Fireplace with Logs
Serial #: 6674



Acucraft Fireplaces
19672 172nd Street
Big Lake, MN 55309

www.acucraft.com 888-317-6499

SAFETY

INSTALLATION GUIDELINES:

- Acucraft does not install fireplace systems.
- Contact a licensed installer for proper installation.

Installation and repair should be done by a qualified service person. The appliance should be inspected before use and at least annually by a professional service person. More frequent cleaning may be required due to excessive lint from carpeting, bedding material, etc. It is imperative that control compartments, burners, and circulating air passageways of the appliance be kept clean.

Instructions are included for removal and re-installation of the glass panels. Only tempered glass is certified for use with this appliance. This fireplace is NOT certified to be used without a glass front and sides. DO NOT use if any portion or pane of glass is broken, cracked, damaged, or otherwise visually flawed. Contact a technician to replace the damaged panel immediately.

Do not use this appliance if any part has been under water. Immediately call a qualified service technician to inspect the appliance and to replace any part of the control system and any gas control which has been under water.

This appliance is not for use with glass doors.

INSTALLATION SAFETY CODES:

These instructions should be used as a guideline only, and do not supersede local codes in any way. Please check with local codes before installation.

In the absence of local codes, use the current National Fuel Gas Code – ANSI Z223.1 (NFPA 54) or CAN/CGA B149 Installation Code.

The appliance, when installed, must be electrically grounded in accordance with local codes or, in the absence of local codes, with the National Electrical Code, ANSI/NFPA 70, or the Canadian Electrical Code, Part 1 CSA C22.1.

Installed venting must conform to local codes or, in the absence of local codes, to National Fuel Gas Code (ANSI-Z223.1) or to CAN/CSA-B149.1

SAFETY STATEMENTS:

Safety is very important and is referenced throughout this manual in different ways. There are two different safety levels that you should be aware of. Warning statements will occur when there is a possibility of bodily harm present. Caution statements will occur when there presents a risk of damage to the unit if the statements are not followed correctly. Below are examples of what the statements look like.



SAFETY



WARNING



FIRE & EXPLOSION HAZARD

Gasoline or flammable vapors can ignite or explode. Do not store or use gasoline or other flammable vapors and liquids in the vicinity of this or any other appliance. Follow lighting instructions provided on the label of the fireplace and in this manual. If the information in these instructions are not followed exactly, a fire or explosion may result causing property damage, personal injury or loss of life.



VENTILATION

Make sure the appliance has proper ventilation as instructed in this manual. Gas vapors can cause personal injury or loss of life.

What to do if you smell gas:

- Do not try to light any appliance
- Do not touch any electrical switch
- Immediately call gas supplier from a neighbor's phone. Do not use any phone in the building.
- Follow the gas supplier's instructions
- If you can not reach your gas supplier, call the fire department.



HOT SURFACE HAZARD

The glass on the fireplace will become hot while in use. Hot glass will cause burns. Keep children away from hot surface to avoid burns or clothing ignition. Never touch glass until cooled. If burns occur, seek immediate medical attention.

SAFETY



DANGER



CARBON MONOXIDE HAZARD

This appliance can produce carbon monoxide which has no odor.

Using it in an enclosed space can kill you.

Never use this appliance in an enclosed space such as a camper, tent, car or home.



DANGER

If you smell gas:

- Shut off gas to the appliance.
- Extinguish any open flame.
- If odor continues, keep away from the appliance and immediately call your gas supplier or fire department.



WARNING

Do not store or use gasoline, or other flammable vapors and liquids, in the vicinity of this or any other appliance.

An LP-cylinder not connected for use shall not be stored in the vicinity of this or any other appliance.



WARNING

Improper installation, adjustment, alteration, service or maintenance can cause injury or property damage. Read the installation, operating, and maintenance instructions thoroughly before installing or servicing this equipment.

SAFETY

**⚠ DANGER • FLAMMABLE GAS UNDER PRESSURE.
LEAKING LP-GAS MAY CAUSE A FIRE OR EXPLOSION IF IGNITED
CAUSING SERIOUS BODILY INJURY OR DEATH.
CONTACT LP GAS SUPPLIER FOR REPAIRS, OR DISPOSAL OF THIS
CYLINDER OR UNUSED LP-GAS.**

**⚠ WARNING • FOR OUTDOOR USE ONLY.*
DO NOT USE OR STORE CYLINDER IN A BUILDING,
GARAGE OR ENCLOSED AREA.**

⚠ WARNING:

- Know the odor of LP-gas. If you hear, see or smell leaking LP-gas, immediately get everyone away from the cylinder and call the Fire Department. Do not attempt repairs.
- Caution your LP-gas supplier to:
 - Be certain cylinder is purged of trapped air prior to first filling.
 - Be certain not to over fill the cylinder.
 - Be certain cylinder requalification date is checked.
- LP-gas is heavier than air and may settle in low places while dissipating.
- Contact with the liquid contents of cylinder will cause freeze burns to the skin.
- Do not allow children to tamper or play with cylinder.
- When not connected for use, keep cylinder valve turned off. Self contained appliances shall be limited to a cylinder of 30 lb capacity or less.
- Do not use, store or transport cylinder where it would be exposed to high temperatures. Relief valve may open allowing a large amount of flammable gas to escape.
- When transporting, keep cylinder secured in an upright position with cylinder valve turned off.

WHEN CONNECTING FOR USE:

- Use only in compliance with applicable codes.
- Read and follow manufacturer's instructions.
- Consult manufacturer's instructions concerning the cylinder connection provided with your appliance.
- Be sure regulator vent is not pointing up.
- Turn off all valves on the appliance.
- Do not check for gas leaks with a match or open flame. Apply soapy water at areas marked "X". Open cylinder valve. If bubble appears, close valve and have LP-gas service person make needed repairs. Also, check appliance valves and connections to make sure they do not leak before lighting appliance.
- Light appliance(s) following manufacturer's instructions.
- When appliance is not in use, keep the cylinder valve closed.

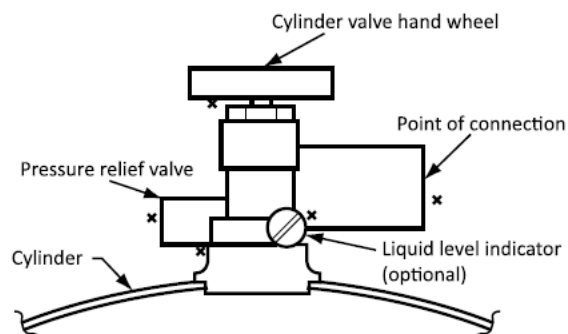

**DO NOT REMOVE, DEFACE, OR OBLITERATE THIS LABEL
*EXCEPT AS AUTHORIZED BY ANSI/NFPA 58.**

⚠ DANGER. Do not store a spare LP cylinder under or near a barbecue grill, or other heat sources. NEVER fill an LP cylinder beyond 80% full: a fire causing death or serious injury may occur.

SAFETY

Due to high temperatures, the appliance should be located out of traffic and away from furniture and draperies.

Clothing or other flammable material should not be placed on or near the appliance.

Children and adults should be alerted to the hazards of high surface temperature and should stay away to avoid burns or clothing ignition.

Young children should be carefully supervised when they are in the same room as the appliance. Toddlers, young children and others may be susceptible to accidental contact burns. A physical barrier is recommended if there are at-risk individuals in the house. To restrict access to a fireplace or stove, install an adjustable safety gate to keep toddlers, young children and other at-risk individuals out of the room and away from hot surfaces.

Any safety screen or guard removed for servicing an appliance, including glass panels, must be replaced prior to operating the appliance.

INSTALLATION GUIDE

This is a vented decorative gas appliance: not a source of heat; not for use with solid fuel.

IMPORTANT NOTE TO INSTALLER:

1. This appliance is not intended or designed to be installed in a mobile or manufactured home.
2. If this appliance is installed on carpeting, tile, or any combustible material other than wood flooring, the appliance shall be installed on a metal, concrete, or wood panel extending the full width and depth of the fireplace.
3. The appliance and its main gas valve must be disconnected from the gas supply piping system during any pressure testing of that system at test pressures in excess of ½ psi. (3.5 k/Pa) The appliance must be isolated from the gas valve supply piping system by closing the equipment shutoff valve during any pressure testing of the gas supply piping system at test pressures equal to or less than ½ psi (3.5 k/Pa)

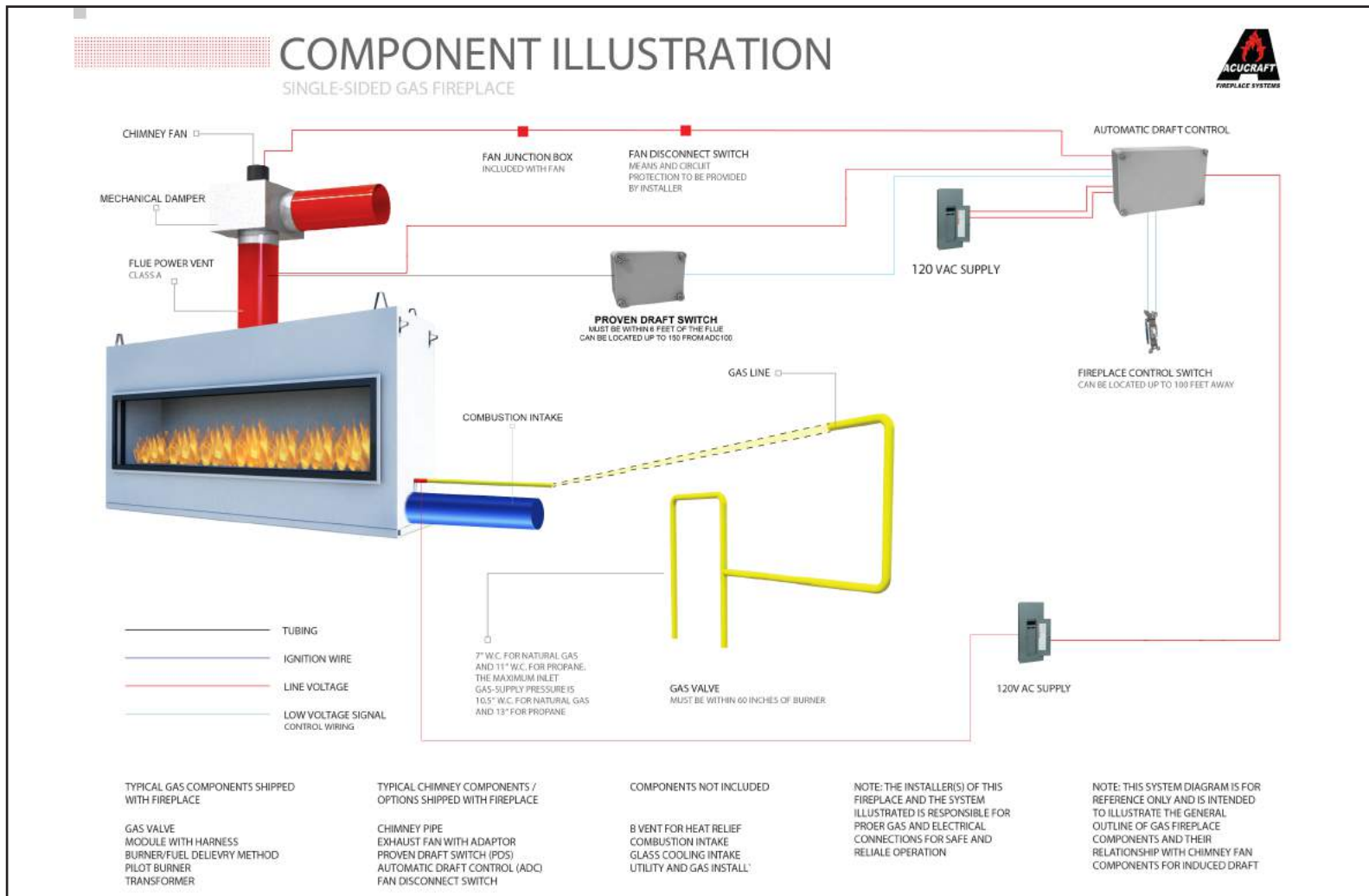

INSTALLATION GUIDE

Fireplace Wiring Diagram

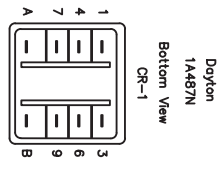
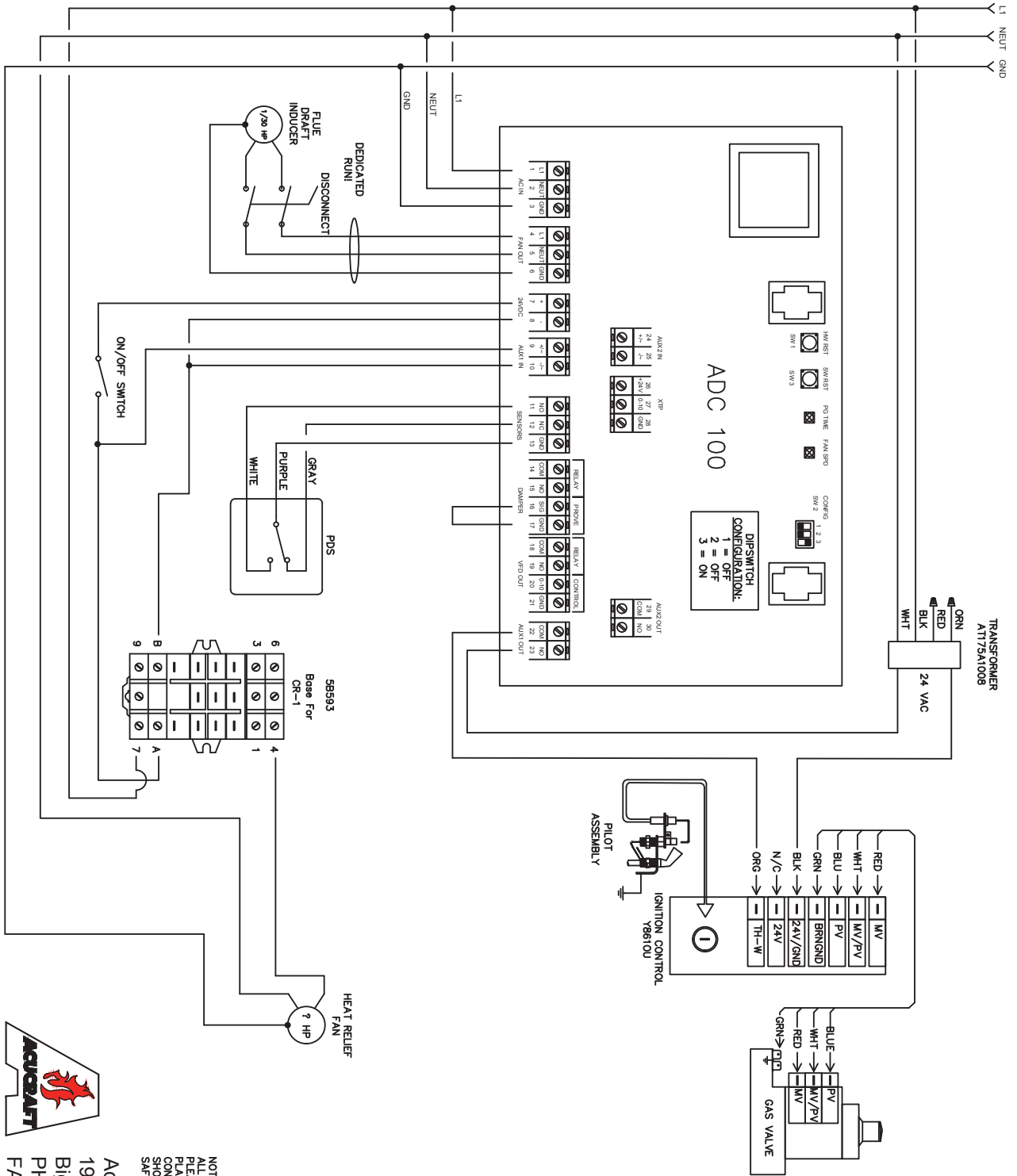

NOTE: INSTALLATION MUST CONFORM WITH ALL LOCAL CODES AND ORDINANCES. PLEASE READ ALL LITERATURE BEFORE PLANNING YOUR INSTALLATION AND CONTACT RESPECTIVE MANUFACTURERS SHOULD YOU NEED CLARIFICATION. SAFETY TEST ENTIRE SYSTEM WHEN DONE!

Acucraft Fireplace Systems
19672 172nd ST. NW
Big Lake, MN 55309
PH. 763-263-3156
FAX 763-263-8311



INSTALLATION GUIDE

Positioning the Fireplace

Using a hand truck or other appropriate equipment, that is rated to handle the weight of the fireplace safely move the fireplace into position. (estimated weight 1500 lbs)



Determine the location of the appliance to ensure that the combustion air supply and the flue gas/chimney pipe connections are to be made as designed. The appliance is designed to sit either directly on the floor or to sit on a base designed to support the weight of the appliance for proper elevation. If shimming is required to level the appliance due to uneven surfaces, shimming the perimeter of the base is the preferred method. Anchor the appliance adequately to prevent future movement.

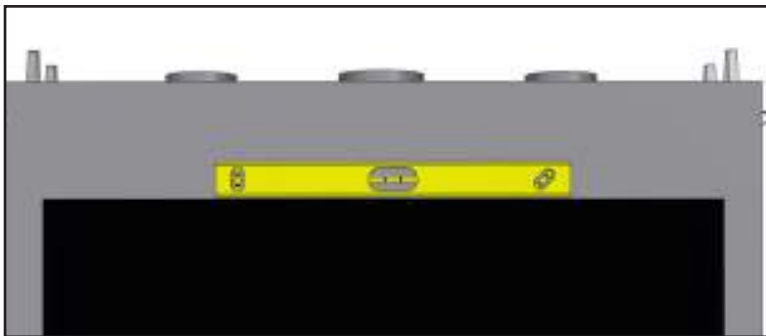

Clearance to combustibles:

Top of appliance = 4"

Sides of appliance = 2"

Back of appliance = 2"

Bottom of appliance = 0"

Vent clearance to combustibles:

Class A exhaust flue = 2"

B-vent heat relief venting = 1"

IMPORTANT: Clearances must be in accordance with local installation codes and the requirements of the gas supplier.

Les dégagements sont conformes aux codes d'installation locaux et aux exigences du fournisseur de gaz.

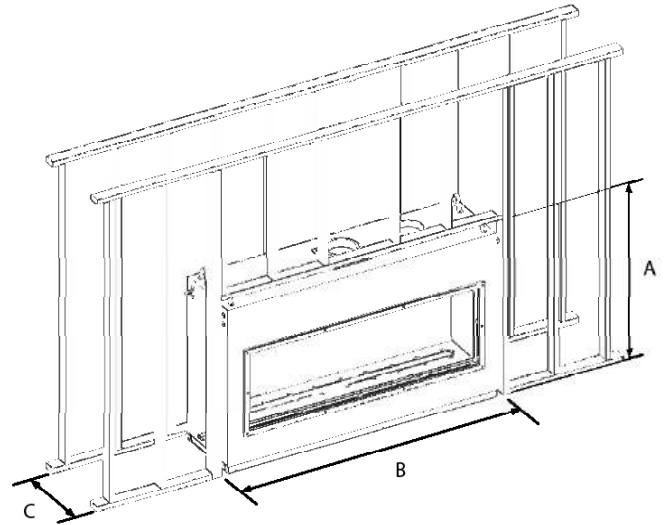

A	B	C
58"	60"	26"

Note: The appliance should be positioned in a manner that planned electrical and gas line access is available with adequate clearance for servicing.

INSTALLATION GUIDE

		US installations ²
A	Clearance above grade, veranda, porch, deck or balcony	12in (30 cm)
B	Clearance to window or door that may be opened	6 in (15 cm) for appliances ≤ 10,000 Btuh (3 kW), 9 in (23 cm) for appliances > 10,000 Btuh (3 kW) and ≤ 50,000 Bruh (15 kW), 12 in (30 cm) for appliances > 50,000 Btuh (15 kW)
C	Clearance to permanently closed window	*
D	Vertical clearance to ventilated soffit located above the terminal within a horizontal distance of 2 feet (61 cm) from the center line of the terminal	*
E	Clearance to unventilated soffit	*
F	Clearance to outside corner	*
G	Clearance to inside corner	*
H	Clearance to each side of center line extended above meter / regulator assembly	*
I	Clearance to service regulator vent outlet	*
J	Clearance to nonmechanical air supply inlet to building or the combustion air inlet to any other appliance	6 in (15 cm) for appliances ≤ 10,000 Btuh (3 kW), 9 in (23 cm) for appliances > 10,000 Btuh (3 kW) and ≤ 50,000 Bruh (15 kW), 12 in (30 cm) for appliances > 50,000 Btuh (15 kW)
K	Clearance to a mechanical air supply inlet	3 ft (91 cm) above if within 10 ft (3 m) horizontally
L	Clearance above paved sidewalk or paved driveway located on public property	*
M	Clearance under veranda, porch deck, or balcony	*

Notes:

1) In accordance with the current CSA B149.1, Natural Gas and Propane Installation Code.

2) In accordance with the current ANSI Z223.1/NFPA 54, National Fuel Gas Code.

*For clearances not specified in ANSI Z223.1/NFPA 54 or CSDA B149.1, one of the following shall be indicated:

a) A minimum clearance value determined by testing in accordance with Clause 5.25.5, or;

b) A reference to the following footnote:

“Clearance in accordance with local installation codes and requirements of the gas supplier.”

† A vent shall not terminate directly above a sidewalk or paved driveway that is located between two single family dwellings and serves both dwellings.

‡ Permitted only if veranda, porch, deck, or balcony is fully open on a minimum of two sides beneath the floor.

SUPPLEMENTAL MATERIAL

VENT REQUIREMENTS

Vent Requirements

- The gas appliance and vent system must be vented directly to the outside of the building, and never be attached to a chimney serving a separate solid fuel or gas-burning appliance. Each direct vent gas appliance must use its own separate vent system.
- In addition to the requirements listed here, follow the requirements provided with the vent.

Vent Clearances

- The vent must maintain the required clearance to combustible materials to prevent a fire. Do not fill air spaces with insulation.
- Minimum Vent Configurations (elbow directly off fireplace):
- Clearances are in accordance with local installation codes and requirements of the gas supplier.
- Les dégagements sont conformes aux codes d'installation locaux et aux exigences du fournisseur de gaz.

Minimum Clearance Above Vent	2"
Minimum Clearance to Sides & Below Vent	2"

Vent Firestop

- A firestop is required whenever the vent penetrates a wall, floor, or ceiling (passes through framing members)

Approved Vent

- Installation instructions for ICC Excel Factory Built Chimney may be found at: www.icc-rsf.com

Vent Installation

- Slide the vent sections together, use screws provided with flue (3 screws at each joint).
- No silicone is required
- Wall supports are required at a minimum of every 8 feet.

INSTALLATION GUIDE

Connecting the Gas Valve & Ignition System

IMPORTANT:

All connections and components should be made and installed by qualified persons only and checked and tested for leaks prior to wiring of valve module.

Gas supply should be connected as shown below.

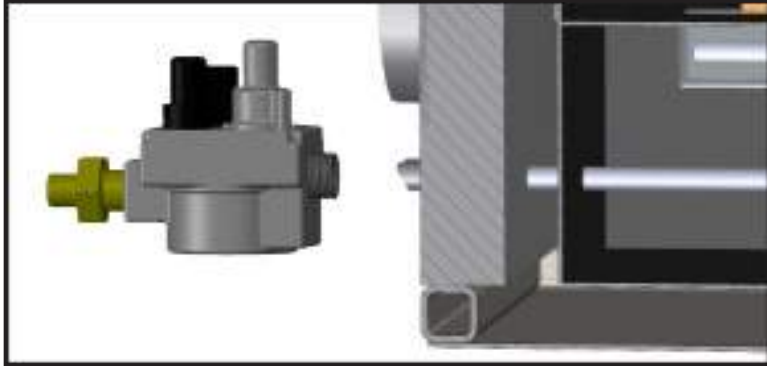

The location of the stubbed gas line port and electrical pass through port for running the ignition cable are determined during design. The location may either be directly with the fireplace, or these components may be remotely located nearby, but never in a location to exceed 5' length of ignition cable from the burner itself.

Please refer to the specific component installation manuals for the electronic gas valve, intermittent pilot module, pilot assembly, and transformer supplied with this fireplace and written by the manufacturer.

- Connect the ignition cable and other wiring to the valve and direct intermittent pilot module as shown below.

NOTE: These illustrations are not to scale and are for reference only. For more detailed schematics, refer to appropriate components in back of this manual.

Directions for Connecting a Gas Pressure Test Gauge

The gas control valve (shown to the right) has two test ports for testing input (line pressure) and output (manifold) pressure. Loosen the brass screw on either test port and place a 5/16" i.d. rubber or plastic tube over the tapered test port. Connect the tube to the test gauge.

WARNING: The brass screw must be tightened after testing to prevent gas leakage.

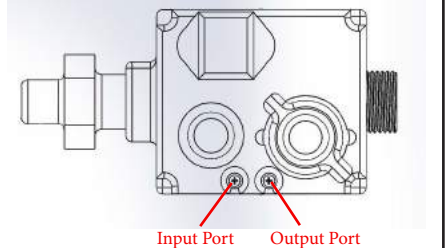

INSTALLATION GUIDE

Installing the Log Set



WARNING

Always wear protective equipment when dealing with open flames. Failure to follow this warning may result in serious injury.

Log placement is very important for the proper operation of the Real-Fyre® gas log set. Although you have some flexibility in the log arrangement, it is necessary to follow the LOG PLACEMENT instructions carefully to fully enjoy your log set. Follow the steps below, referring to Fig. 7-1 through Fig. 7-5.

1. The second-longest log, the rear log, is placed on the rear of the grate with the bark of the log facing forward (Fig. 7-1). Center the log left to right (Fig. 7-5 #1). If the log has a head chamber (a recess in the back), it can face either forward or to the rear.
2. The longest log, the front log, is placed on the front of the grate with the bark facing forward. Center left to right (Fig. 7-2 #2). If the log has a heat chamber, it should face to the rear. **NOTE: Be sure to maintain a space between the front and rear logs** (Fig. 7-1). This creates energy efficiency, heat radiation, and reduces carbon buildup.
3. Top logs should be stacked diagonally, with the largest at the bottom (Fig. 7-3, #3 & 4), and with spaces between the logs so that the flames are not choked off. Place the smaller logs diagonally across the larger ones (see Fig. 7-4, #5 & 6). The top logs may be moved to achieve desired flame pattern. Some carbon buildup (sooting) may occur where the flames impinge on the logs and should not be a concern unless excessive. If sooting is excessive, rearrange the top logs to reduce flame impingement. Examples of log stacks are shown below.

Note: Although log styles may differ in pattern or shape (Fig. 7-6), layout is essentially the same. Adequate spacing between the logs is NECESSARY and MUST be maintained for best performance.

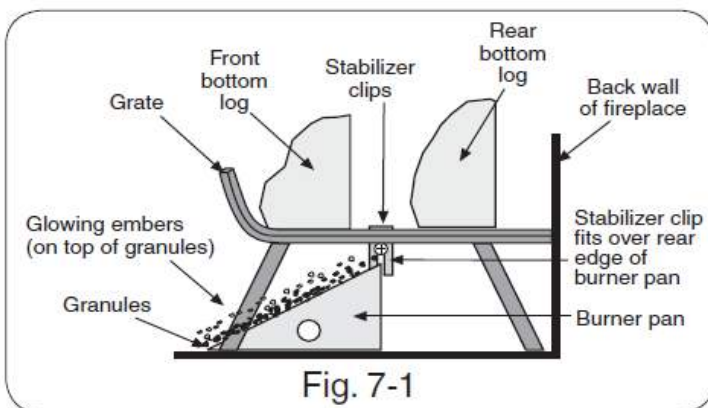

INSTALLATION GUIDE

Installing the Log Set

STEP 1. Place the second-longest log to the rear.



Fig. 7-2

STEP 2. Place the longest log at the front.

STEP 3. Place the largest top logs across the bottom logs.

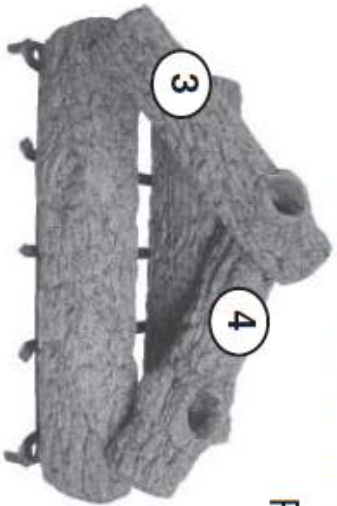

Fig. 7-3

Knotholes go to the front or back as desired.

Alternative examples of log layout (Split Oak set shown). Note the space between the logs.

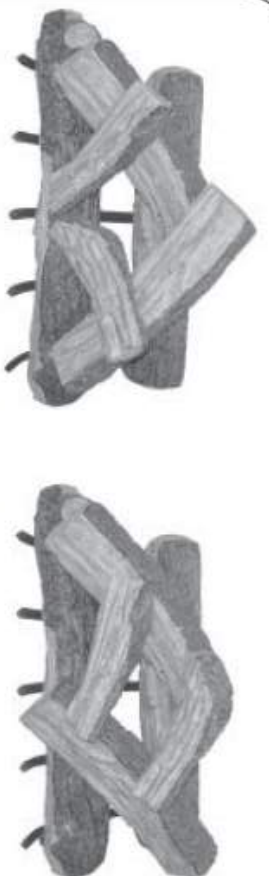

Fig. 7-5

STEP 3 (cont.) Place the smaller top logs across the other logs.

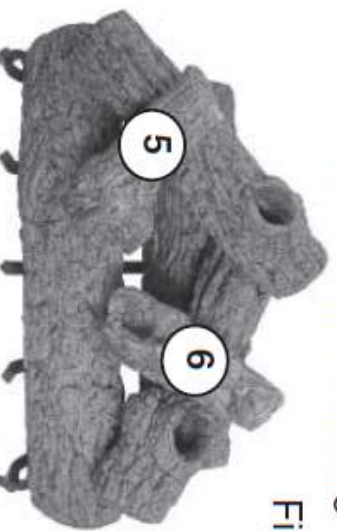

Fig. 7-4

(Note the gaps between the logs.)

Note: 24" Golden Oak (R-24) shown

Royal English
Oak Designer



Split Oak
Designer Plus



Woodland
Oak

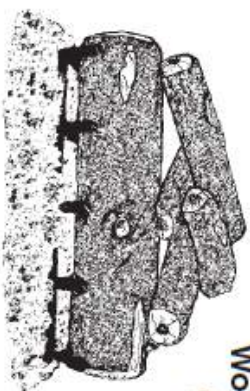

Fig. 7-6 - Recommended log patterns

INSTALLATION GUIDE

Installing the Log Set

Note: Optional Charred Series log sets are supplied with an ember screen (Fig. 8-1).

Attach the ember screen to the burner by slipping it onto the back edge (center left to right) with the perforated section facing toward the back fireplace wall (Fig. 8-1). Cover the surface of the ember screen with the Glowing Embers (Fig. 8-2). For best glowing performance, they should be applied evenly and pulled slightly apart so the fibers are somewhat loose. (It is not necessary to pile the entire bag of the Glowing Embers. More Glowing Embers may be added after completion of the entire installation).

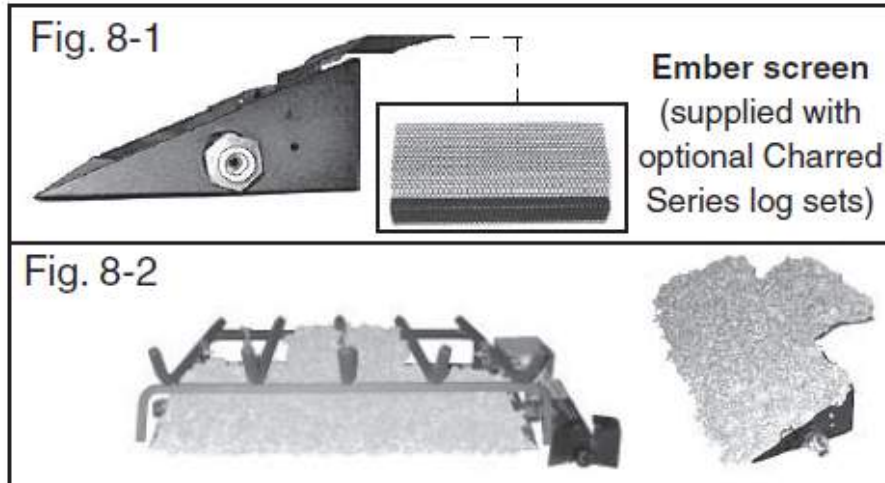

LOG PLACEMENT

Log styles and sizes will vary depending upon the Charred Series log set ordered.
CHARRED SPLIT (CHS) layout shown.

Place the long bottom rear log (Log #2) on the back of the grate with the flat featureless side facing the rear of the fireplace. The two sections of the front log (Logs #1A & 1B) are placed on the front of the grate with the charred sections facing each other and approximately 1 inch apart at the top (Fig. 8-3). Slide the logs to the front of the grate.

Note: Be sure to maintain a space between the front and rear logs (Fig. 8-3). This creates energy efficiency and heat radiation, and reduces carbon buildup.

Place the two curved logs (Logs #3 & 4) so that one end rests on each front log section (Logs #1A & 1B) and the other end rests on the rear log (Log #2).

The charred sections should be over the opening between the front and rear logs (Fig. 8-4).

Place the small top charred logs (Logs #5 & 6) so they rest over the charred sections of the front bottom log sections (Logs #1A & 1B) and on the two curved logs (Logs #3 & 4) (Fig. 8-5).

Finally, place the curved top charred log (Log #7) to rest on the two top logs at rear, but not encroaching into the space between rear and front logs (Fig. 8-6).

Note: The additional log (Log #7) is not available with 18" log sets.

INSTALLATION GUIDE

Installing the Log Set



Fig. 8-3



Fig. 8-4

Fig. 8-5



MAINTAIN A SPACE IN THE CENTER OF THE LOGS AT ALL TIMES

Fig. 8-6

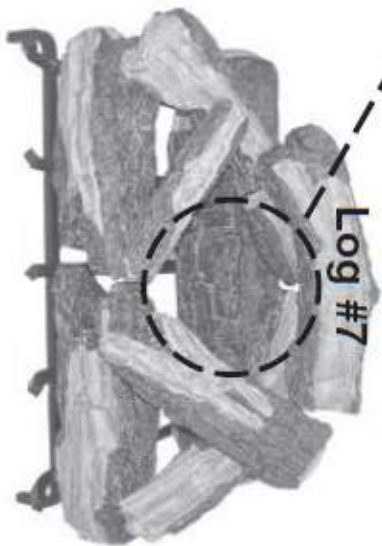

REPLACEMENT COMPONENTS INFORMATION

IMPORTANT:

This fireplace system consists of several components that are designed specifically for this appliance. No parts on this appliance may be substituted or replaced with anything other than original components. Replacement parts as listed below can be obtained by contacting Acucraft Customer Service by phone or email.

Acucraft Customer Service Contact Information:

- Phone: (763) 263-3156
- Email: info@acucraft.com

COMPONENT DESCRIPTION	INSTALL INFORMATION PAGE(S)
Flue / Venting	14-17
Log Set	18-22
Draft Controller	23-25
Gas Valve & Ignition Module	26-30
Draft Switch	31-32
Inline Fan	33
Chimney Fan	34-39

WARNING:

Failure to position the parts in accordance with these diagrams or failure to use only parts specifically approved with this appliance may result in property damage or personal injury.

AVERTISSEMENT:

Risque de dommages ou de blessures si les pièces ne sont pas installées conformément à ces schémas et ou si des pièces autres que celles spécifiquement approuvées avec cet appareil sont utilisées.

SUPPLEMENTAL MATERIAL

Draft Controller

Product Information

USE:

The Control Board is a fan speed and appliance control used to control draft for a gas appliance such as a fireplace, stove or furnace. It may be interlocked with the appliance and is for use in systems where modulation is not required. It controls the speed of a fan to maintain proper draft and pressure in a chimney system. The Control Board is for use with chimney fans.

FUNCTION:

The Control Board comes with the Draft Switch.

The Draft Switch is a required safety function used to ensure a negative pressure is maintained in the chimney. It also prevents appliance operation during an electrical or mechanical failure in the system.

The Control Board can operate the chimney fan in manual or automatic mode. Manual mode allows the user to adjust the speed of the fan at any time using the potentiometer on the board. In Automatic Mode, the Control Board will ignore the potentiometer and ramp the fan up until the Draft Switch closes. If the Draft Switch opens, the control will ramp up the fan until there is enough draft to re-close the switch.

CONSTRUCTION:

The housing is NEMA 1 rated ABS plastic.

CODE COMPLIANCE:

System installation must conform to the requirements of the authority having jurisdiction. When required by the authority having jurisdiction, the installation must also conform to the NFPA31, NFPA54 or NFPA211. All electrical wiring must be in accordance with the requirements of the authority having jurisdiction or, in absence of such requirements, with the National Electric Code, NFPA 70.

Shipping Information

The Control Board includes the control unit, Draft Switch, stack probe and silicone tubing.

* If other components are shipped, they will appear as separate items on the packing list.

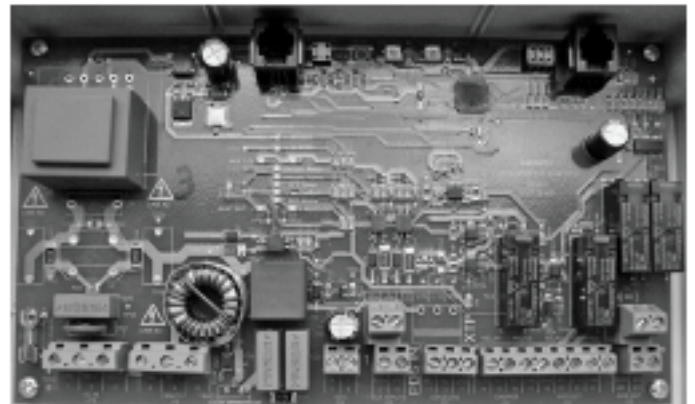

SUPPLEMENTAL MATERIAL

Draft Controller

Specifications

Dimensions & Capacities:	
Power Supply = V	1x120 VAC
Amperage = A	6.3
Operating Temp = °F/°C	-4 to 122 / -20 to 50
Control Signal = mA	max. 10
Control relay	max. 120 VAC / 8A
Output	VAC = 10-120 VDC = 0-10
Post Purge Time	0-3 Minutes
Alarm Delay Time	15 Seconds
Dimensions (see below)	
Weight = lbs/kg	2.6 / 1.2

Dimensions		
Control Board	A	9.6 in / 244 mm
	B	6.3 in / 160 mm
	C	3.5 in / 90 mm
Chimney Probe	D	4.25 in / 108 mm
	E	3.50 in / 89 mm

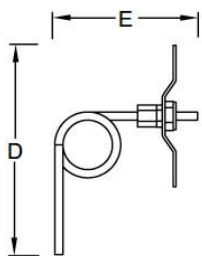
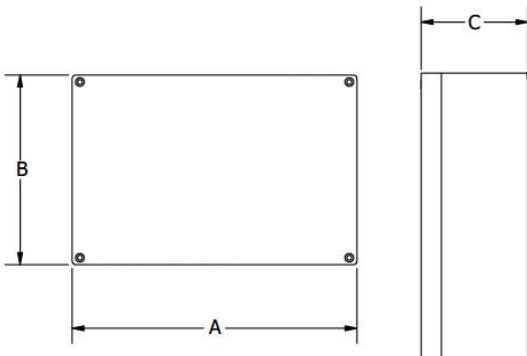

Mechanical Installation

LOCATION:

The Control Board must be installed indoors.

As shown in the diagram below, the control will be wired directly to a 120/1/60 VAC power supply. The control will also be connected to the fan, appliance and damper (if used). For detailed wiring information, see Electrical Installation.

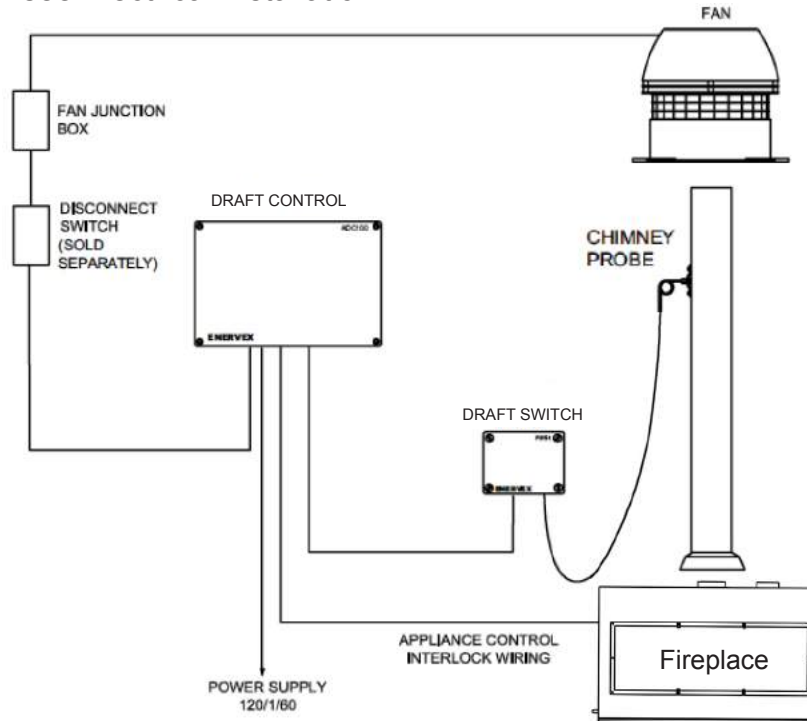

MOUNTING THE CONTROL UNIT:

The Control Board may be mounted directly to a wall. To mount, remove the cover and locate the (4) mounting holes. Using the hole-pattern shown below, mount the control using #6 screws. Once it is attached, wire the unit in accordance with Electrical Installation section of this manual.

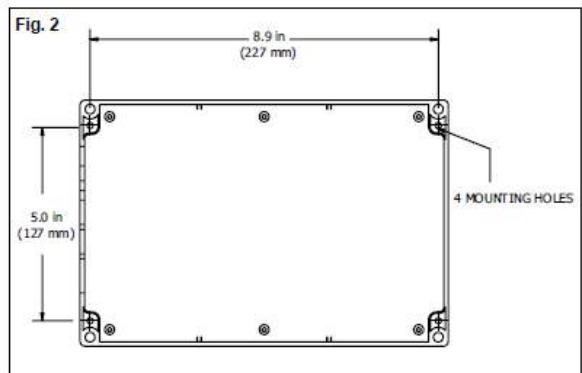

SUPPLEMENTAL MATERIAL

Draft Controller

CONNECTION OF THE DRAFT SWITCH AND STACK PROBE:

The Draft Switch must be installed indoors, in the vertical position (pre-drilled knockouts face down). Mount the control upright to a wall or other flat surface. Do NOT lay the control down or mount horizontally.

A Draft Switch must be used with the Control Board as a system safety device. The Draft Switch monitors the pressure inside the stack and signals the control to shut down the appliance if insufficient draft exists. A stack probe senses the pressure read by the Draft Switch and is connected via silicone tubing.

The silicone tubing supplied with the Draft Switch should be connected to the NEGATIVE (-) port of the Draft Switch. This is the bottom port on the switch. The standard tube length is 6 feet. The distance can be extended up to 25 feet by using 1/4" rigid plastic or copper tubing as temperature allows (not supplied).

The image below is for reference only; the draft switch must be installed in a vertical position.

INSTALLATION OF THE CHIMNEY PROBE:

The probe must be installed between the appliance and the exhaust fan. If a damper is used in the system, the probe should be installed between the appliance and damper.

Locate the probe at least a distance three (3) vent diameters away from any elbow, tee or damper. For fireplace installations, the probe should be installed close to the fan inlet as shown below.

To produce an accurate pressure reading, the probe should be installed flush with the inner wall of the chimney or stack. If double walled stack is used, the probe should be flush with the inner most wall.

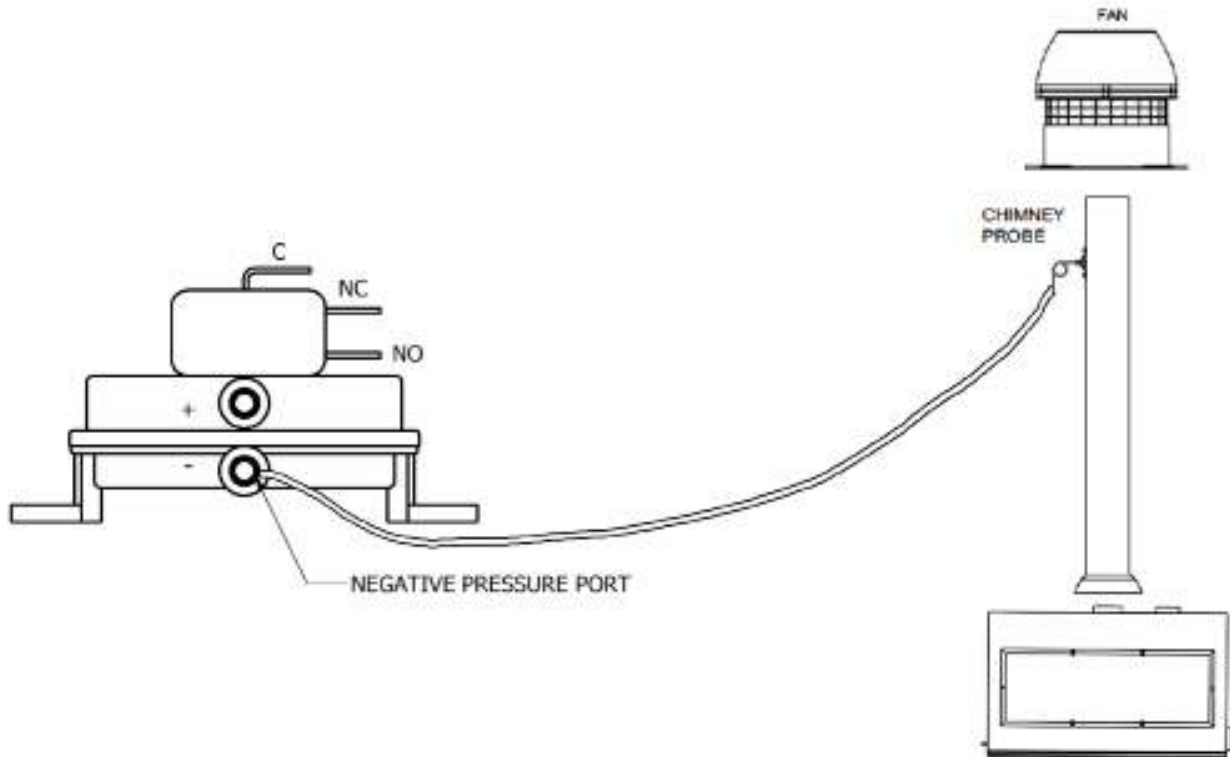

SUPPLEMENTAL MATERIAL

Gas Valve & Ignition Module

Application

Pilot burners provide main burner ignition for standing pilot natural and LP gas systems. Used with a thermocouple to provide automatic pilot safety control. Used with a thermopile in a self-powered system. See Table 1 for model specifications.

TABLE 1—MODEL SPECIFICATIONS.

Model	Primary Aerated	Type of Orifice	Pilot Tip Type	Includes
Q314A	No	Insert	Target	Includes natural and LP gas orifices, 1/4 in. compression fitting, "F," "K," or "L" tip styles, "B" mounting bracket, and "A" mounting bracket adapter.
Q327A	Yes	Spud	Target	Includes natural and LP gas orifices, 1/4 in. compression fitting, and "B" mounting bracket with screws.

Installation

WHEN INSTALLING THIS PRODUCT...

1. Read these instructions carefully. Failure to follow instructions can damage product or cause a hazardous condition.
2. Check ratings given in instructions and on product to make sure product is suitable for your application.
3. Make sure installer is a trained, experienced service technician.
4. After completing installation, use these instructions to check out product operation.



WARNING

**FIRE OR EXPLOSION HAZARD
CAN CAUSE PROPERTY DAMAGE,
SEVERE INJURY, OR DEATH**

Follow these warnings exactly.

1. Disconnect power supply before wiring to prevent electrical shock or equipment damage.
2. To avoid dangerous accumulation of fuel gas, turn off gas supply at appliance service valve before starting installation and perform Gas Leak Test after completion of installation.
3. Do not bend pilot tubing at the control or pilot after compression nut has been tightened. Gas leakage at the connection may result.

Follow appliance manufacturer's instructions if available; otherwise, use instructions provided below.

LOCATION

1. Position pilot burner for easy access, observation, and lighting. In replacement applications, replace pilot burner

with an identical unit and position new pilot burner in the same location and orientation as the original pilot burner.

2. Mount pilot burner on main burner. Mounting surfaces other than the main burner can shift, bend, or warp as furnace expands and contracts while operating. See Fig. 1.

3. Mount pilot burner so the ignition flame remains properly positioned with respect to the main burner flame. See Fig. 2.

4. Supply pilot flame with ample air free of combustion products.

5. Do not impinge pilot flame on adjacent parts. Do not impinge main burner flame on pilot burner.

6. Do not expose pilot flame to falling scale which could impair ignition of main burner.

7. Do not expose pilot burner to main burner rollout while igniting or extinguishing.

8. Do not expose pilot flame to drafts that push or pull pilot flame away from the thermocouple or thermopile.

Fig. 1—Mount pilot burner on main burner.

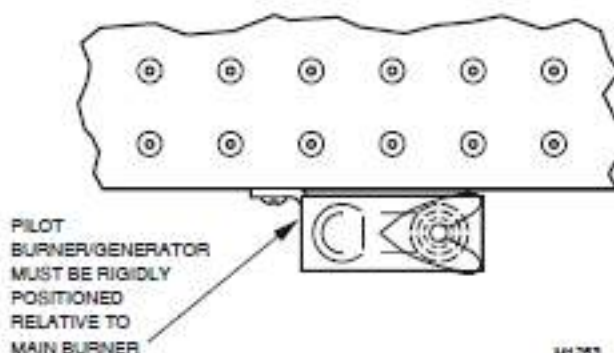

M1283

SUPPLEMENTAL MATERIAL

Gas Valve & Ignition Module

Fig. 2—Location of pilot burner.

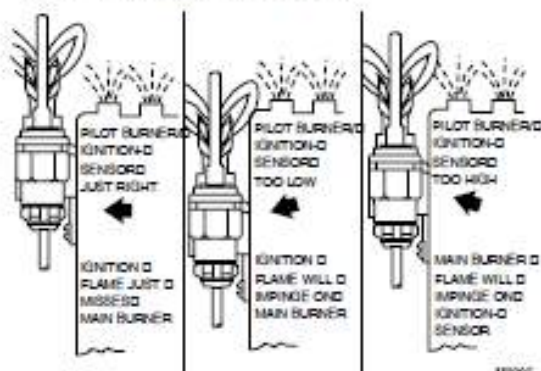

CONNECT PILOT GAS TUBING

1. Cut tubing to desired length and bend as necessary for routing to pilot burner. Do not make sharp bends or deform tubing. Do not bend tubing at control after compression nut has been tightened, as this can result in gas leakage at connection.
2. Square off and remove burrs from end of tubing.
3. Push tubing into compression nut clearance hole until tubing bottoms.

NOTE: When replacing a pilot burner or orifice, cut off old compression fitting and replace with new compression fitting provided with new pilot burner. Never use old compression fitting as it may not provide a gas-tight seal. See Fig. 3.

4. While holding tubing all the way in, engage threads and turn until finger tight.
5. Using a wrench, turn compression nut one turn beyond finger tight. **DO NOT OVERTIGHTEN.**
6. Connect other end of tubing to gas control according to gas control manufacturer instructions.

Fig. 3—Always use new compression fitting.

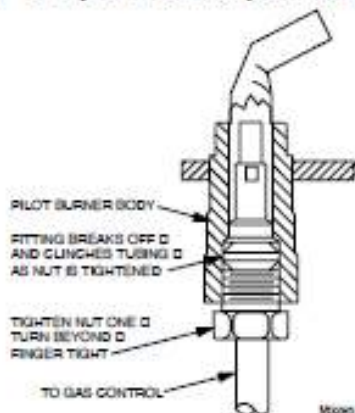

INSTALL THERMOCOUPLE OR THERMOPILE PUSH-IN DESIGN

1. Insert thermocouple or thermopile tip into hole or barrel provided beneath pilot burner. See Fig. 4.
2. Push in firmly until thermocouple or thermopile is locked into place.

ATTACHMENT NUT DESIGN

1. Insert thermocouple or thermopile tip into hole or barrel provided beneath pilot burner. See Figs. 4 and 5.
2. Engage attachment nut threads and tighten until thermocouple or thermopile is locked into place.

Fig. 4—Installing thermocouple or thermopile.

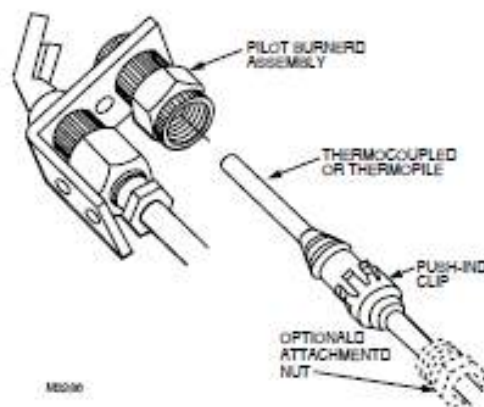
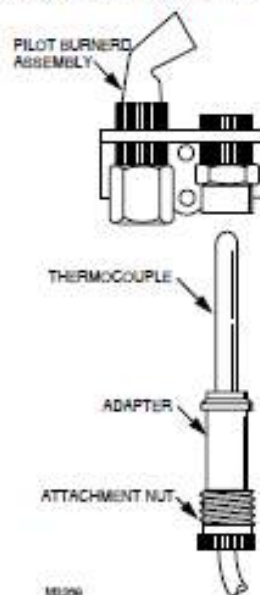

Fig. 5—Installing Q390 Thermocouple.

SCREW-IN TYPE



INSTALL BLEED GAS TUBING (if used):

1. Route bleed gas tubing from bleed tapping on gas control to the pilot burner.
2. Push clip into place. See Fig. 6.
3. Insert bleed gas tubing until 3/8 inch [10 mm] of tubing is above pilot burner bracket. Tip of bleed gas tubing must not extend into pilot flame.

INSTALL "A" MOUNTING BRACKET ADAPTER (optional)

To convert mounting bracket from "B" mounting bracket to "A" mounting bracket, install the "A" mounting bracket adapter to the pilot burner mounting bracket. Then install pilot burner to main burner.

SUPPLEMENTAL MATERIAL

Gas Valve & Ignition Module

Fig. 6—Bleed gas tube installation.

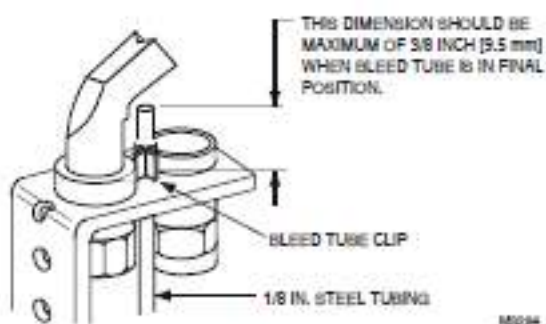

CHANGE INSERT ORIFICES (See Fig. 7)

1. Disconnect pilot tubing from the pilot burner and remove insert orifice. Sometimes a light force is required to remove the orifice.

2. Cut off old compression fitting.

NOTE: When replacing an orifice, cut off old compression fitting and replace with a new compression fitting. Never use old compression fitting as it may not provide a gas-tight seal. See Fig. 3.

3. Square off end of pilot tubing and remove all burrs.

4. Insert new compression nut over pilot tubing and slide out of the way.

5. Insert new orifice into pilot burner and push pilot tubing into the pilot burner until it bottoms.

6. While holding tubing all the way in, slide compression fitting into place and engage threads. Turn until finger tight.

7. Using a wrench, tighten compression fitting one turn beyond finger tight.

CHANGE SPUD ORIFICES (See Fig. 7)

1. Disconnect pilot tubing from orifice.

2. Unscrew old spud orifice and discard.

3. Cut off old compression fitting.

NOTE: When replacing an orifice, cut off old compression fitting and replace with a new compression fitting. Never use old compression fitting as it may not provide a gas-tight seal. See Fig. 3.

4. Square off end of pilot tubing and remove all burrs.

5. Insert new compression nut over pilot tubing and slide out of the way.

6. Insert new orifice into pilot burner and tighten securely.

7. Push pilot tubing into orifice until it bottoms.

8. While holding tubing all the way in, slide compression fitting into place and engage threads. Turn until finger tight.

9. Using a wrench, tighten compression fitting one turn beyond finger tight.

Fig. 7—Changing spud and insert orifices.

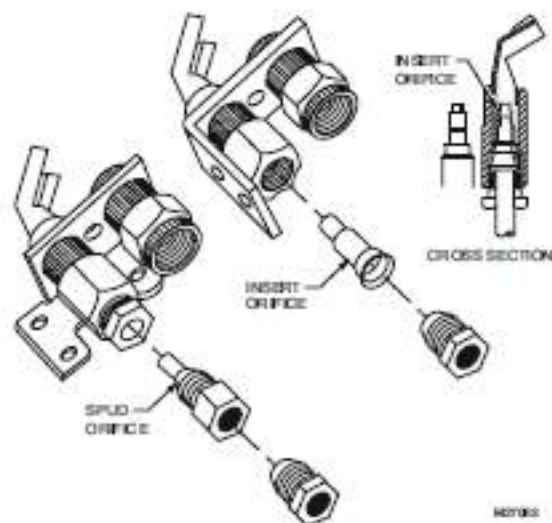

Startup and Checkout

PERFORM GAS LEAK TEST



WARNING

**FIRE OR EXPLOSION HAZARD
CAN CAUSE PROPERTY DAMAGE,
SEVERE INJURY, OR DEATH**

Check for gas leaks with soap and water solution any time work is done on a gas system.

GAS LEAK TEST:

1. Ensure that gas supply is turned on at the appliance service valve.

2. Paint pipe connections upstream of pilot burner with rich soap and water solution. Bubbles indicate gas leak.

3. If leak is detected, tighten pipe connections.

4. Stand clear of main burner while lighting to prevent injury caused from hidden leaks which could cause flashback in the appliance vestibule. Light main burner.

5. With main burner in operation, paint pipe joints (including adapters) and gas control inlet and outlet with rich soap and water solution.

6. If another leak is detected, tighten adapter screws, joints, and pipe connections.

7. Replace part if leak can not be stopped.

ADJUST PILOT FLAME

The pilot flame should envelop 3/8 to 1/2 in. [10 to 13 mm] of the thermocouple or thermopile tip. See Fig. 8. To adjust pilot flame:

1. Remove pilot adjustment cover screw from gas control.

2. Turn inner pilot adjustment screw clockwise ↻ to decrease or counterclockwise ↻ to increase pilot flame.

3. Always replace pilot adjustment cover screw and tighten firmly after completing adjustment to ensure proper operation.

SUPPLEMENTAL MATERIAL

Gas Valve & Ignition Module

Fig. 8—Thermocouple or thermopile tip must be in pilot flame.

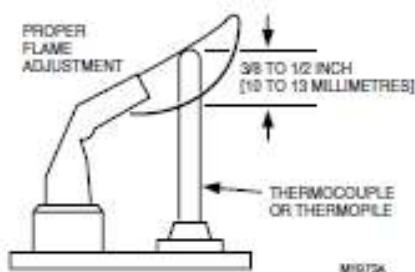

IGNITE PILOT BURNER

1. Before lighting pilot burner, turn thermostat to its lowest setting. Wait for unburned gas to vent.

NOTE: LP gas is heavier than air and will not vent upward. Smell for LP gas next to floor. If you smell gas, shut off the main valve in the gas piping, or, ONLY, AT THE TANK. Perform Gas Leak Test to recheck all connections.

2. Light pilot burner according to appliance manufacturer's instructions.

Service



WARNING

**FIRE OR EXPLOSION HAZARD
CAN CAUSE PROPERTY DAMAGE,
SEVERE INJURY, OR DEATH**

Perform Gas Leak Test anytime work is done to the system.

PILOT OUTAGE





1. If pilot flame goes out during normal operation, but is properly adjusted, recheck Mounting and Location instructions on page 1.

2. If all mounting and location instructions are followed but pilot continues to go out, construct shielding to protect pilot flame from main burner ignition and extinction and drafts. See Fig. 9.

3. Check pilot flame characteristics.

- Check the pilot flame with the main burner operating.
- Ensure the pilot flame continuously covers the tip of the thermocouple or thermopile, the spark gap and 3/8 to 1/2 in. [10 to 13 mm] of the ground rod. See Fig. 8.
- Ensure the pilot flame is blue (a yellow tipped flame is acceptable on LP systems), soft and steady. See Fig. 9 for examples of possible pilot flame problems and their causes.
- If pilot burner is damaged, replace it with an identical pilot burner and mount and position in the same location and orientation.

Fig. 9—Examples of unsatisfactory pilot flames.

APPEARANCE	CAUSE
 SMALL BLUE FLAME	CHECK FOR LACK OF GAS FROM: • CLOGGED ORIFICE FILTER • CLOGGED PILOT FILTER • LOW GAS SUPPLY PRESSURE • PILOT ADJUSTMENT AT MINIMUM
 LAZY YELLOW FLAME	CHECK FOR LACK OF AIR FROM: • LARGE ORIFICE • DIRTY LINT SCREEN, IF USED • DIRTY PRIMARY AIR OPENING, IF THERE IS ONE • PILOT ADJUSTMENT AT MINIMUM
 WAVING BLUE FLAME	CHECK FOR: • EXCESSIVE DRAFT AT PILOT LOCATION • RECIRCULATING PRODUCTS OF COMBUSTION
 NOISY LIFTING BLOWING FLAME	CHECK FOR: • HIGH GAS PRESSURE
 HARD SHARP FLAME	THIS FLAME IS CHARACTERISTIC OF MANUFACTURED GAS. CHECK FOR: • HIGH GAS PRESSURE • ORIFICE TOO SMALL

PILOTSTAT SAFETY CONTROL POWER UNIT FAILURE

1. Ensure pilot flame is properly adjusted.
2. Ensure power unit connections clean and tight.
3. If power unit still fails to hold in, use the W129A Millivoltmeter to obtain the open and closed circuit voltage generated by the thermocouple or generator.
4. Compare measured open and closed circuit voltage values to Acceptable Range Charts in W129A Manual.
5. If W129A Millivoltmeter or other meter is not available, replace thermocouple or thermopile. If this does not correct the condition, replace power unit.

THERMOCOUPLE OR THERMOPILE PERFORMANCE

Thermocouples and thermopiles require proper temperature differential between the hot-junction (tip) and cold-junction (base) to provide satisfactory operation of gas controls. Thermocouples and thermopiles perform less effectively when exposed to excessive cold-junction or hot-junction temperatures.

Excessive cold-junction temperatures can be caused by heat radiation from adjacent surfaces or high ambient air temperatures. Excessive cold-junction temperatures can be eliminated by shielding the pilot flame, see Fig. 10, or constructing a baffle to direct secondary air over the pilot burner base.

Excessive hot-junction temperatures can be eliminated by proper pilot flame adjustment. To adjust pilot flame, see Adjust Pilot Flame section.

SUPPLEMENTAL MATERIAL

Gas Valve & Ignition Module

Fig. 10—Proper shielding of pilot flame.

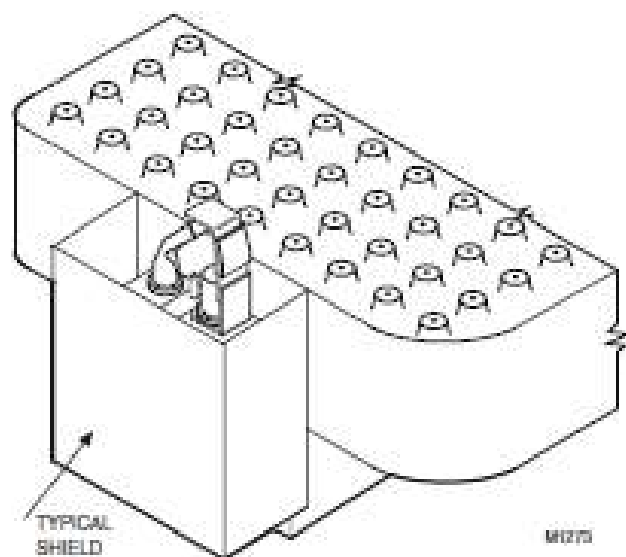



PILOT TURNDOWN TEST (30 mV safety control systems)

The Pilot Turndown Test assures that the pilot flame ignites the main burner within four seconds from the time gas reaches the main burner. In this test, the pilot flame is just sufficient enough to hold in the power unit or just above the point of flame extinction (whichever occurs at a higher pilot gas flow rate).

1. With the pilot and main burner operating, shut off the main burner by either lowering the thermostat temperature setting or turning the gas control knob to the PILOT position.

NOTE: If using a Honeywell W129A Millivoltmeter, turn the pilot gas adjustment screw until the thermocouple open circuit voltage is 2 mV. Omit steps 2,3, and 4 and proceed with step 5.

2. Turn the pilot gas adjustment screw clockwise until the pilot begins to decrease in size. Then, turn the pilot gas adjustment screw clockwise  1/4 turn at a time (waiting one minute between each turn to allow the thermocouple to cool) until safety shutoff power unit just drops, causing safety shutdown

3. Turn pilot gas adjustment screw counterclockwise slightly. 
4. Relight pilot burner. The power unit should hold in.
5. Turn gas control knob to ON position and set thermostat temperature setting above room temperature. Main burner should light within four seconds without flame rollout. If not, check pilot mounting and location instructions in Location section and repeat Pilot Turndown Test.
6. Readjust pilot burner flame. See Adjust Pilot Flame section.

EFFECTIVE IGNITION TEST (750 mV SYSTEMS)

The Effective Ignition Test assures that the pilot flame ignites the main burner within four seconds from the time gas reaches the main burner. In this test, the pilot flame is just sufficient to open the main gas valve.

1. Light the main burner according to the appliance manufacturer's instructions and allow to burn at least five minutes.

2. Remove one thermostat lead (TH) at the gas control terminal.

3. Using the pilot gas adjustment screw, decrease the pilot flame until it begins to pull away from the thermopile. Allow thermopile to cool for one minute.

4. Temporarily jumper the thermostat terminals (TH) on the gas control.

5. If the main burner ignites, reduce the pilot flame by turning the pilot adjustment screw 1/4 turn at a time until the valve fails to pull in. Allow the thermocouple to cool at least one minute between each reduction in the pilot flame level.

6. Increase the pilot flame just enough to pull in the gas control main valve.

7. Jumper the thermostat terminals. The main burner should light within four seconds and without flame roll-out. If it does not, check the Location and Mounting instructions on page 1 and repeat steps 1 through 6.

8. If main burner still does not light, replace thermopile and repeat steps 1 through 6.

9. Remove the jumper to shut off the main burner.

10. Readjust pilot burner flame. See Adjust Pilot Flame section.

11. Reconnect the thermopile lead and ensure all connections are correct and the system is functioning properly.

Draft Switch

Mechanical Installation

INSTALLATION OF DRAFT SWITCH

The Draft Switch is for indoor installation only. The Draft Switch must be installed in a vertical position with the pressure connection pointing down. Secure the switch by using the mounting holes as shown on the gure. After installation connect the tubing from the probe onto the port marked accessible through the small of the plastic enclosure. Connect tubing to the NEGATIVE (-) port on the Draft Switch.

Factory wiring comes with three wires that are already crimped onto the Draft Switch. The purpose of these wires is to provide a point in which you can extend the length of the wire by using wire nuts and additional wire (not provided).

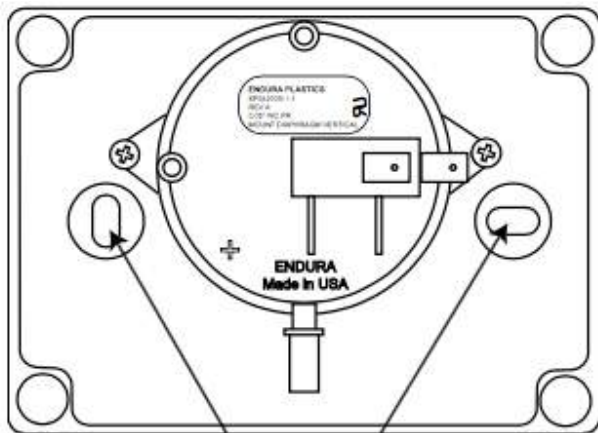

Mounting holes

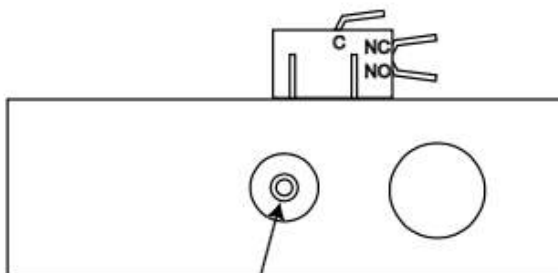

Connection for tubing at the bottom of the enclosure

INSTALLATION OF STACK PROBE FOR PDS 1:

A stack probe is used with Draft Switch. The Draft Switch monitors the pressure inside the stack and signals the control to shut down the appliance if insufficient draft exists inside the stack. The probe must be installed between the appliance and the exhaust fan.

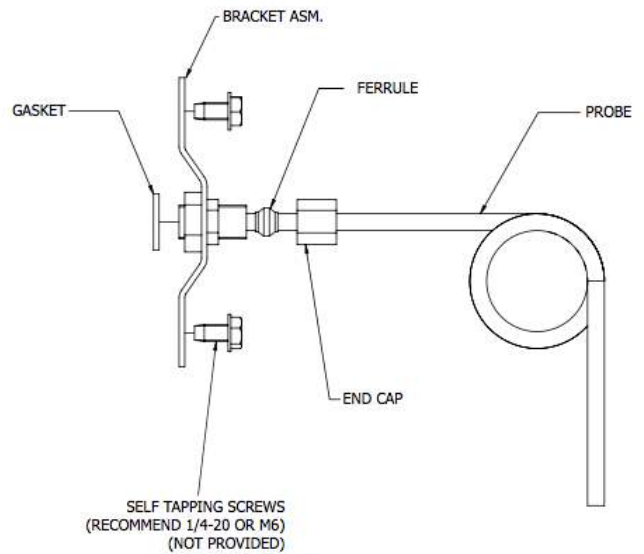

For all installations, the stack probe must be placed so the flow through the stack is perpendicular to the tip of the probe. Locate the probe at least the distance "A" away from any elbows or tees in the stack. The distance "A" is designed as at least three (3) vent diameters; $A \geq 3 * V$ (see figure below). To prevent condensation from entering the probe or Draft Switch when installed on a horizontal stack, the probe must be installed above the centerline of the stack. For replace installations, the stack probe should be installed as close to the exhaust fan as possible.

Draft Switch

For all installations, the stack probe must be placed so the flow through the stack is perpendicular to the tip of the probe. Locate the probe at least the distance “A” away from any elbows or tees in the stack. The distance “A” is designed as at least three (3) vent diameters; $A \geq 3 * V$ (see figure below). To prevent condensation from entering the probe or Draft Switch when installed on a horizontal stack, the probe must be installed above the centerline of the stack. For replace installations, the stack probe should be installed as close to the exhaust fan as possible.

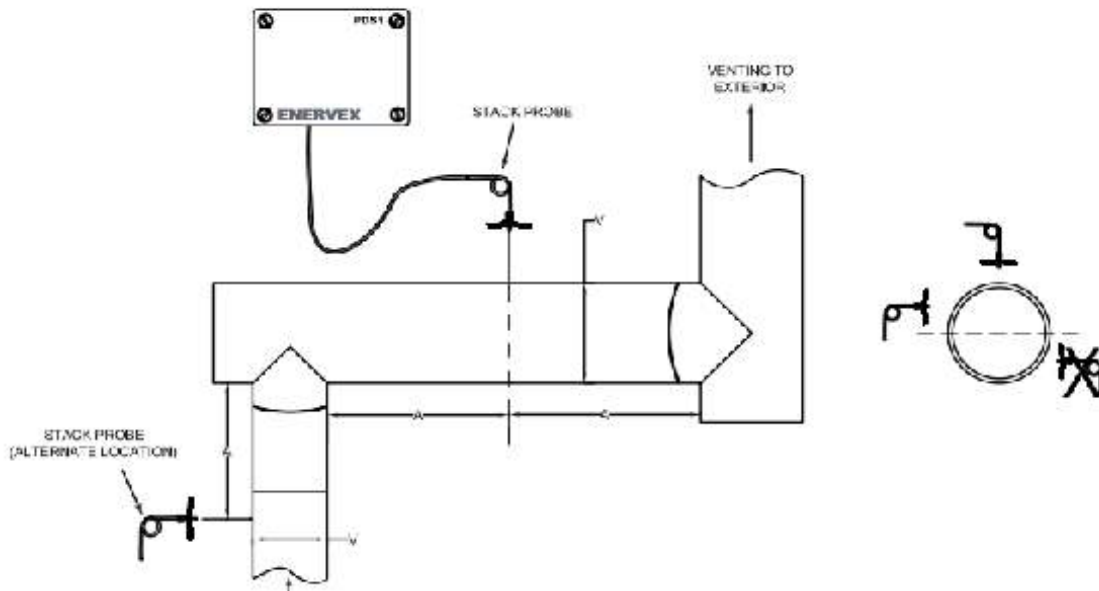

Mechanical Installation (cont.)

INSTALLATION OF STACK PROBE FOR Draft Switch (cont.):

For the Draft Switch to function properly, the probe must be placed in a location that can produce at least 0.05 in/WC in the stack. In order to produce an accurate pressure reading, the tip of the probe must be mounted flush with the inside of the stack wall (it should never extend more than 1/16" beyond the wall). For a double walled stack, the tip should be flush with the inner most wall.

To mount the probe, drill a clearance hole through the stack wall(s). Insert the probe and attach the bracket to the stack using (2) customer provided self-tapping machine screws. Tighten the end cap to compress the ferrule and permanently install the stack probe. Attach the supplied silicon tubing at the other end of the probe.

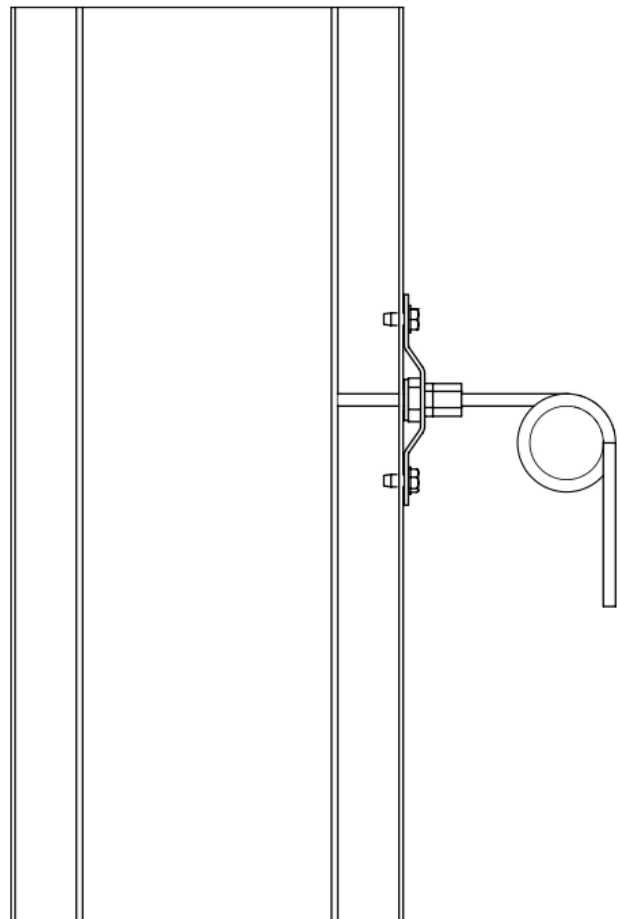

SUPPLEMENTAL MATERIAL

Inline Fan

Installation and Maintenance

INSTALLATION (cont.):

DIMENSION MODEL FG

Dimensions in in

Model	A	C	D	E	F
8, 8XL	8	13 ³ / ₈	6	1 ¹ / ₈	1 ¹ / ₈

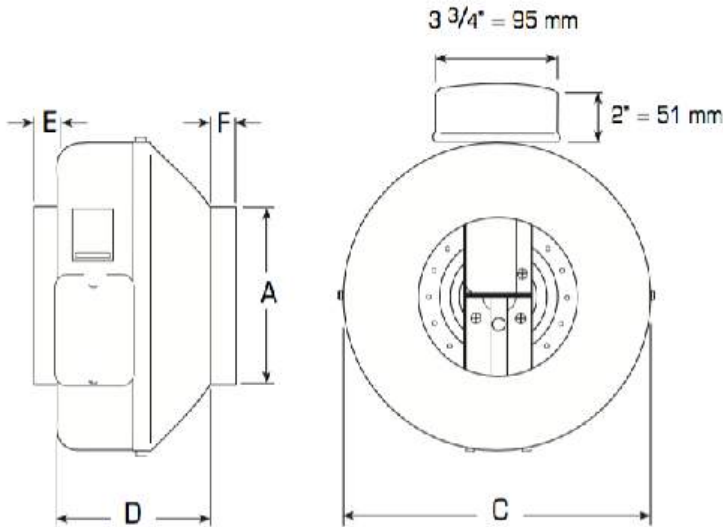

WIRING:



CAUTION

All installation should be wired according to the following diagrams.

Failure to comply will cause the motor to "hum" or not work.

Note: Liquid tight wiring must be used for outside applications.

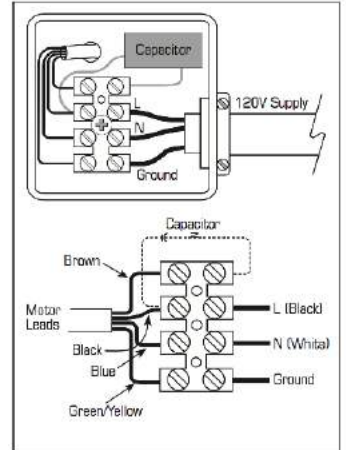

Instruction for all model FG fans

With motor speed controller

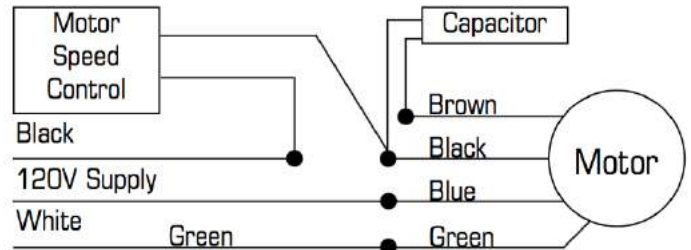

Without motor speed controller

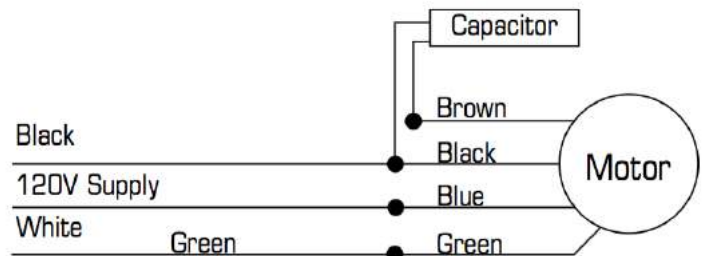

SUPPLEMENTAL MATERIAL

Chimney Fan

Dimensions & Capacities

Model	Chimney Fan
Discharge	Horizontal
Fan Type	Axial Vane
Motor Type	Totally enclosed, variable speed, Class H
Voltage (VAC)	1 x 120
RPM	1600
CFM (0.0Ps)	450
Amperage (Amps)	0.5
Motor Output (HP)	1/30
Motor Output (kW)	0.025
Weight (lbs)	29
Weight (kg)	13
Dimensions A (In)	10.2
Dimensions A (mm)	259
B x B (In)	11.7
B x B (mm)	296
C (In)	10.8
C (mm)	275
D (In)	3.0
D (mm)	75
E (In)	9.4
E (mm)	238
Temperature (Intern.)	575°F/300°C

Sound Data:

Lw dB (measured in accordance with ISO 3744)							Lp dB(A)
125Hz	250Hz	500Hz	1000Hz	2000Hz	4000Hz	8000Hz	
54	50	47	43	38	31	25	21

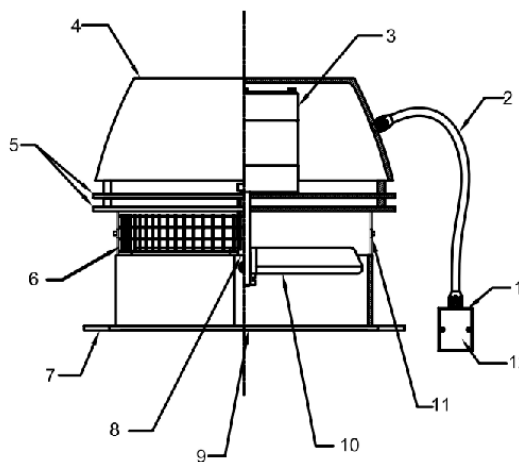
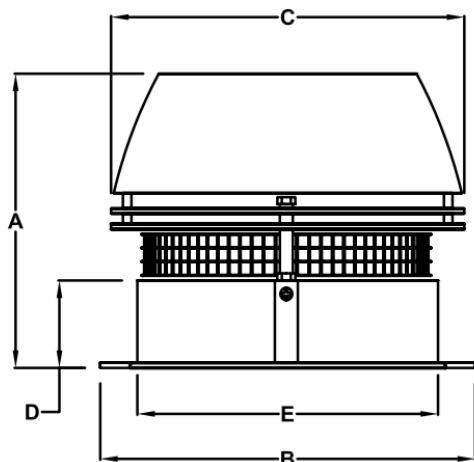

1. Junction Box
2. Conduit / Cord
3. Motor
4. Motor Housing
5. Cooling Plates
6. Bird Screen
7. Base Plate
8. Locking Nut
9. Inlet
10. Axial Vane
11. Hinges
12. Capacitor
(Inside Junction Box)

Chimney Fan

Planning Ahead



WARNING

1. Observe proper combustion air requirements.
2. Provide a firm support system for the chimney fan.
3. Determine the type of system involved.
4. Observe proper safety measures are taken to assure safe use of the wood burning appliances.

Support system for the chimney fan: Prior to installation of the chimney fan, it must be assured the chimney can safely carry the weight of the chimney fan.

A steel chimney should be well supported at the roof penetration point.

Combustion Air Requirements: Provisions for combustion air must be in accordance with applicable local codes.

If the heating system is installed in an unconfined space, adequate air will be available via normal infiltration.

If the heating system is installed in a confined space, (a space with a volume less than 50 cubic feet per 1,000 Btu/hr of input for all fuel burning equipment) or building construction is unusually tight, adequate air for combustion must be provided by two openings: one located about 6" below the ceiling, the other about 6" above the floor. **Each opening must have a minimum free area as follows:**

1. One square inch per 2,000 Btu/hr when communication through horizontal ducts to the outside.
2. One square inch per 1,000 Btu/hr when ventilation air is provided by openings in doors, etc. to adjoining spaces having adequate infiltration.



WARNING

Adequate fresh air must be provided for combustion; otherwise, improper operation and inadequate venting of deadly flue gases may result.

SUPPLEMENTAL MATERIAL

Chimney Fan

Single Fan on Steel Chimney

Step 1: Prepare fan location

The steel chimney adapter (SCA) slides right into the chimney, where the long collar engagement ensures safe anchoring.

Step 2: Preparation of fan

Locate the installation brackets in the grooves on the underside of the fan base, using the bolts and nuts supplied to secure the brackets. Note that the bolts shall be installed from the bottom side in the two inner holes.

Adjust the final position of the installation brackets ensuring that there is a small gap between the brackets and the flue wall/adaptor throat. Tighten the nuts. If the brackets touch the flue wall, it may create some vibration noise.

Step 3: Attaching the fan

The chimney fan is now ready for installation on the top of the chimney. It is not necessary to bolt the fan to the chimney.

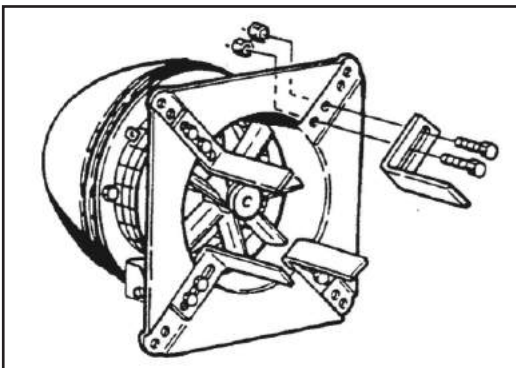
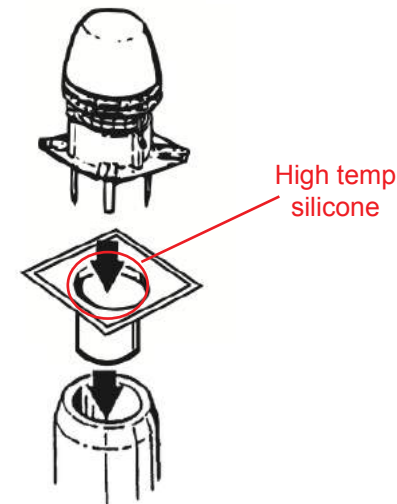

CAUTION

Under conditions with extremely strong winds surrounding the top of the chimney, the chimney fan must be secured by steel wires supplied with the fan.

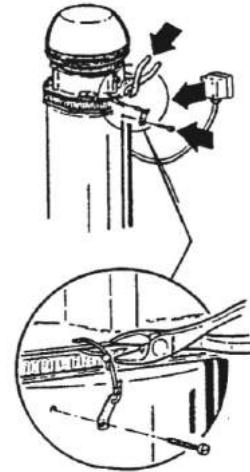

Wall Mounting of Chimney Fan

When mounting the chimney fan on a wall, the installation instructions for installation on a steel chimney should be followed. Use of the adapter SCA can make the installation easier.

To ease installation, detach the fan base by removing the bolts holding the hinges together. Center the fan base over the outlet and bolt the base onto the wall with the hinges pointing upwards.

After mounting the base securely, attach the fan motor housing by reassembling the fan hinges. Seal with high temp silicone all around the edges.

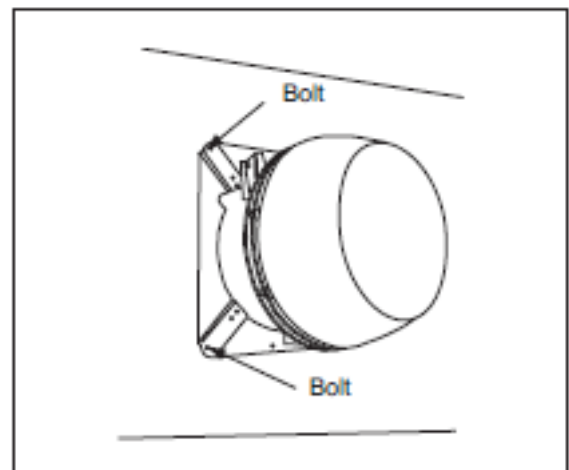

Chimney Fan



CAUTION

A safety device that prevents the heating appliance operation, in case of a power failure or inadequate draft situation, must be installed.

Termination of Venting System

In order to achieve optimal performance and energy consumption for the RS Fan the duct must be installed as shown below and the distances observed. From the last elbow to the termination point the distance has to be 3 times the diameter of the flue. For example if you using 12in flue ($12 \times 3 = 36$ in). So the distance from the last elbow to the fan termination point should be 36 inches.

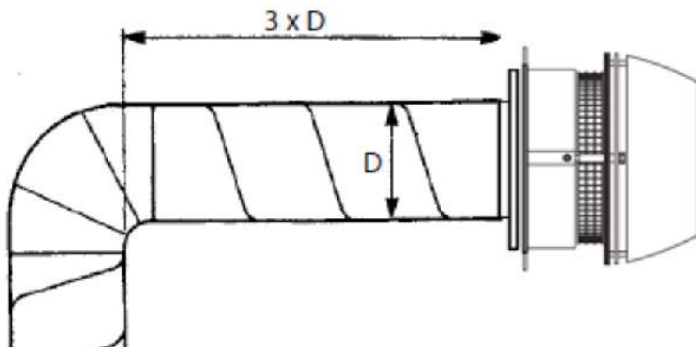

A venting system that terminates in the sidewall of a structure shall terminate at least 3 ft (0.9 m) above any air inlet to the structure that is within 10 ft (3 m) of the termination point.

Exception No. 1: This requirement shall not apply to the combustion air intake of a direct vent appliance.

Exception No. 2: This requirement shall not apply to the separation distance between the circulating air inlet and the vent discharge of a listed outdoor appliance.

The flue gas outlet of an appliance other than a direct vent appliance shall terminate at least 4 ft (1.2 m) below, 4 ft (1.2 m) horizontally from, or 1 ft (0.3 m) above any door, window, or gravity air inlet of the structure. The outlet also shall terminate at least 1 ft (0.3 m) above grade.

The combustion air inlet and flue gas outlet of a direct vent appliance or the flue gas outlet of an appliance other than a direct vent appliance shall terminate at least 1 ft (0.3 m) from the soffit of the roof of the structure and at least 3 ft (0.9 m) from an inside corner of an L-shaped structure.

The flue gas outlet terminal of a direct vent application with an input of 50,000 Btu/hr (0.35 gal/hr) or less shall be located at least 9 in. (230 mm) from any door, window, or air inlet to the structure. The vent terminal of a direct vent appliance with an input over 50,000 Btu/hr (0.35 gal/hr) shall be located at least 1 ft (0.3 m) from any door, window, or air inlet to the structure. Regardless of input, the flue gas outlet terminal shall also terminate at least 1 ft (0.3 m) above grade.

The exit terminals of mechanical draft systems shall not be less than 7 ft (2.1 m) above grade when located adjacent to public walkways.

Any air inlet and any flue gas outlet of any appliance shall terminate at least 5 ft (1.6 m) from the vent outlet of a supply tank.

Electrical Installation



WARNING

Turn off electrical power before servicing. Contact with live electric components can cause shock or death.

All electrical wiring must be in accordance with requirements of authority having jurisdiction or, in absence of such requirements, with National Electrical Code NFPA 70 — latest edition. If an external electrical source is utilized, system must be electrically grounded in accordance with requirements of the authority having jurisdiction or, in the absence of such requirements, with the National Electrical Code NFPA 70 — latest edition.

Chimney Fan

Start-Up and Configuration

SYSTEM TESTING

Before any adjustments are made to the system, follow these procedures:

1. Turn the chimney fan ON and make sure that it is operating. Increase and decrease the speed of the fan by adjusting the fan speed control to make sure it is operating properly.
2. Turn the fan OFF and make sure the pressure switch opens, so the power to the circuit, it controls, is disconnected.

WARNING

Check other heating appliances (water heater, furnace, fireplace etc.) for proper operation while the chimney fan is operating. Make sure no flue gases are spilling out as this can lead to carbon monoxide poisoning.

Maintenance

PRIOR TO CLEANING

Remove butterfly nut or screw from each hinge prior to cleaning.

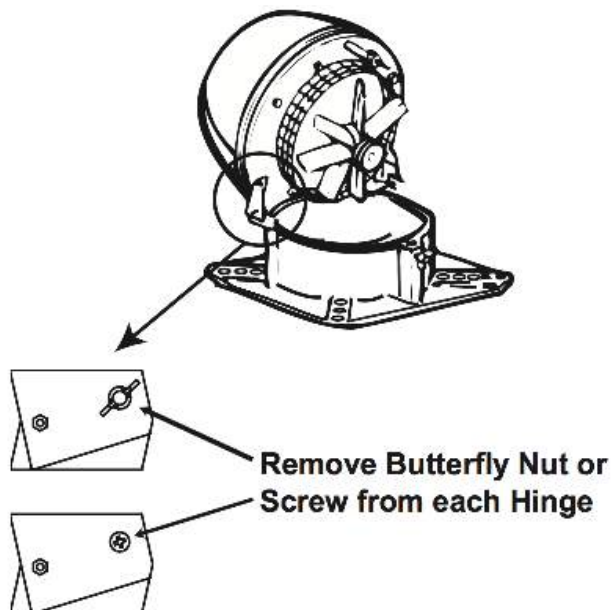

CARE AND CLEANING

The Chimney Fan System is designed for prolonged use. The fan should be inspected at least once a year when the chimney is inspected. Fuel residues and other deposits should be removed from the fan blades and the bottom of the motor housing.

The top of the fan is hinged and can be opened in order to ease the cleaning.

WARNING

Do not open the motor housing unless power to the chimney fan has been disconnected.

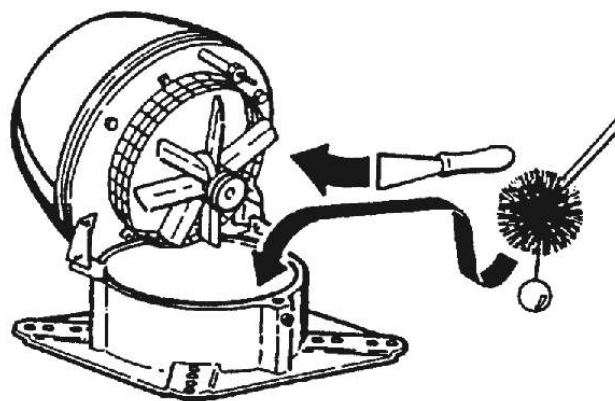

SUPPLEMENTAL MATERIAL

Chimney Fan

Maintenance (cont.)

CHIMNEY CLEANING INTERVALS

It is extremely important to keep the chimney flue clean from products of combustion and deposits. Unburned oil residues can cause a chimney fires.

Cleaning intervals depend on the use of the appliance. The more the appliance is used, the more often the chimney flue needs cleaning. As there are no firm guidelines for cleaning intervals, have the chimney inspected on a regular basis (every quarter or so) to determine what the interval should be. Then follow this interval.

No matter how much used, a chimney flue should be cleaned and inspected at least once every year.

NOTE: The chimney should be cleaned by a trained professional. We recommend using a “Certified Chimney Sweep” certified by Chimney Safety Institute of American. You can find a Certified Chimney Sweep at www.csa.org or www.ncsg.org or by calling (317) 837-5362 or (317) 837-1500.

Troubleshooting

OBSERVATION	PROBLEM	SOLUTION
There is no power going to the fan	<ul style="list-style-type: none">- The circuit breaker may be off- Fan speed control is off- Bad electrical connections	<ul style="list-style-type: none">- Check the circuit breaker- Turn fan speed control on- Check and correct problem
There is power to the fan but it is not operating	<ul style="list-style-type: none">- Bad electrical connections- The fan speed control's low voltage setting is too low- The fan speed control is bad	<ul style="list-style-type: none">- Check and correct problems with connections. Pay special attention to the wiring in the junction box- Increase the setting with the plastic screw on the fan speed control's front plate- Replace the fan speed control
There is power to the fan but it hums and does not turn	<ul style="list-style-type: none">- The motor run capacitor may be bad.- Creosote may stick	<ul style="list-style-type: none">- Check capacitor and replace if necessary- Clean fan
The fan seems to work fine, but there is not enough draft	<ul style="list-style-type: none">- The fan may be undersized	<ul style="list-style-type: none">- Replace with a larger fan
The fan vibrates	<ul style="list-style-type: none">- The motor shaft may be bent- The hinges may be bent	<ul style="list-style-type: none">- Replace motor- Straighten out hinges
There is airflow noise from the draft hood	<ul style="list-style-type: none">- The flue is undersized.- The fan is oversized and running too fast	<ul style="list-style-type: none">- There is not much to do about it- Reduce the fan speed
Mechanical noise can be heard	<ul style="list-style-type: none">- Foreign matter may be stuck- Motor bearings may be worn out	<ul style="list-style-type: none">- Remove foreign matter- Replace bearings

PRODUCT SPECIFICATIONS

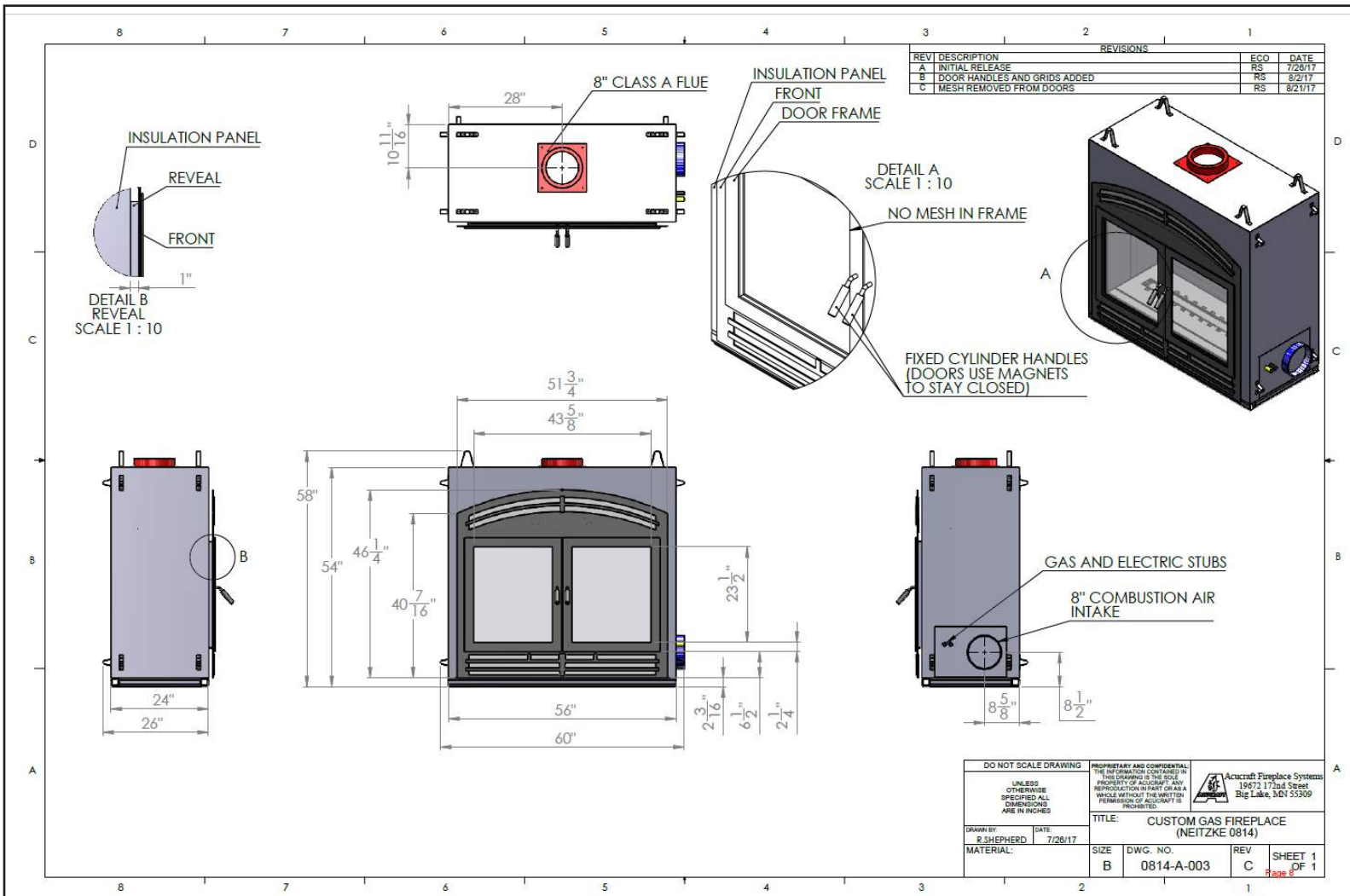

SPECIFICATIONS

Height = 54"
 Width = 56"
 Depth = 24"
 Appx Weight. = 1,250 LBS
 Gas Type = Natural Gas
 Flue Size = 8"
 Flue Type = 103HT
 Electrical = Single 15 AMP service



NATURAL GAS

Input Rating (BTU/hr) 0-1370 m = 100,000 BTUs/hr.
 Minimum inlet pressure (in.w.c.) = 7.0 in. W.C.
 Maximum inlet pressure (in.w.c.) = 10.5 in. W.C.
 Combustion Air inlet size= 8" Round
 Glass Cooling Air inlet size = N/A

Based on testing that was performed, the following results have been recorded.
 Minimum Clearances to combustibles
 Unit to back wall of enclosure = 2 inches
 Unit to sidewall of enclosure = 2 inches
 Unit top to enclosure top = 4 inches
 NOTE: A 8" B-Vent used as a duct to remove heat from the top to the outdoors must be installed to maintain these clearances. (SUPPLIED BY OTHER)

Note: The chimney flue for the appliance should never be connected to another chimney flue in any way.

PRODUCT SPECIFICATIONS

MANUFACTURER: VENTED GAS FIREPLACE Serial #: 6675 Acucraft Fireplaces MODEL: Acucraft Custom Gas 44 with Logs 19672 172nd St Big Lake, MN 55309 (763) 263-3156	
GAS TYPE:	Natural Gas
INPUT RATING (Btu/hr) 0-610m:	100,000
ORIFICE SIZE (DMS) 0-610m:	#L
INPUT RATING (Btu/hr) 610-1370m:	100,000
ORIFICE SIZE (DMS) 610-1370m:	#L
MANIFOLD PRESSURE (in. wc/kPa):	3.5/(0.9)
MINIMUM INLET PRESSURE (in. wc/kPa):	7.0/(1.74)
ELECTRICAL:	120 Vac, 60 Hz, 2 Amps max
VENTED GAS FIREPLACE. NOT FOR USE WITH SOLID FUEL. NOT FOR USE WITH GLASS DOORS.	
Follow installation instruction.	 Minimum clearances to combustibles: Unit to back wall of enclosure: 2 inches Unit to sidewall of enclosure: 2 inches Unit top to enclosure cap: 4 inches
CERTIFIED FOR UNITED STATES ANSI Z21.50 DO NOT REMOVE THIS LABEL	Lab Test 

PRODUCT SPECIFICATIONS

FOR YOUR SAFETY, READ BEFORE OPERATING

WARNING: If you do not follow these instructions exactly, a fire or explosion may result causing property damage, personal injury, or loss of life.

- A. This appliance has a pilot. It is equipped with an ignition device which automatically lights the burner. Do not try to light the burner by hand.
- B. BEFORE OPERATING smell all around the appliance area for gas. Be sure to smell next to the floor because some gas is heavier than air and will settle on the floor.
- WHAT TO DO IF YOU SMELL GAS:
- Do not try to light any appliance
 - Do not touch any electric switch; do not use any phone in your building.
 - Immediately call your gas supplier from a neighbor's phone. Follow the gas supplier's instructions.
- If you cannot reach your gas supplier, call the fire department.
- C. Only use your hand to push in or turn the gas control knob. Never use tools. If the knob will not push in or turn by hand, don't try to repair it, call a qualified service technician. Force or attempted repair may result in a fire or explosion.
- D. Do not use this appliance if any part has been under water. Immediately call a qualified service technician to inspect the appliance and to replace any part of the control system and any gas control which has been under water.

OPERATING INSTRUCTIONS

1. STOP! Read the safety information above on this label.
2. Turn off all electric power to the appliance.
3. This appliance is equipped with an ignition system which automatically lights the burner. Do not try to light the burner by hand.

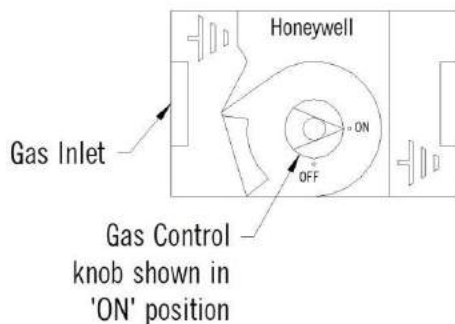

4. Push in gas control knob slightly and turn clockwise  to "OFF"

Note: Knob cannot be turned to "OFF" position unless knob is pushed in slightly. Do not force.

5. Wait five (5) minutes to clear out any gas. Then smell for gas, including near the floor. If you smell gas, STOP! Follow "B" in the safety information above on this label. If you don't smell gas, go to the next step.
6. Turn gas control knob counterclockwise  to "ON"
7. Replace control access panel.
8. Turn on all electric power to the appliance.
9. If the appliance will not operate, follow the instructions "To Turn Off Gas To Appliance" and call your service technician or gas supplier.

TO TURN OFF GAS TO APPLIANCE

1. Turn off all electric power to the appliance if service is to be performed.
2. Remove control access panel
3. Push in control knob slightly and turn clockwise  to "OFF" Do not force
4. Replace control access panel

OPERATION GUIDE

Basic Sequence of Operation

Listed below is a sequence of operation when the fireplace is functioning properly. If you are experiencing problems with the fireplace not operating normally, see the Troubleshooting section.

1. The fireplace control switch is turned on.
2. A signal is sent to Draft Controller turning on the exhaust fan as well as opening the damper.
3. The Draft Switch proves positive draft within the flue.
 - a. Draft proves (go to step 4)
 - b. Draft doesn't prove and system locks out.
(The process will need to be restarted.)
4. A signal is then sent back to the Draft Controller which then signals the valve module to open and ignite the pilot.
5. The pilot spark igniter will discontinue sparking after flame has been proven.
6. The pilot will then send gas to the burner as well as ignite gas and prove the flame is burning.
7. Operation normal.

Lighting the Ignition System (cont.)

For complete lighting instructions refer to "Lighting Instructions" on page 23

Turning gas off to the appliance

Please check with local codes. In the absence of local codes, use the current National Fuel Gas Code – ANSI Z223.1 (NFPA 54).

Turning the fireplace ON

To turn the fireplace ON refer to "Lighting Instructions" on page 23

Lighting the Ignition System

	WARNING
	Follow the instructions below exactly. Failure to follow this warning may result in serious injury or loss of life.
IMPORTANT: This appliance is equipped with an ignition system which automatically lights the burner. DO NOT try to light the burner by hand. Only use your hand to push in or turn gas control. NEVER use tools. Call a qualified technician. Force or attempted repair may result in fire or explosion.	

DRAFT CONTROL OPERATION

Sequence of Operation

The sequence of operation flow chart is shown in the figure below.

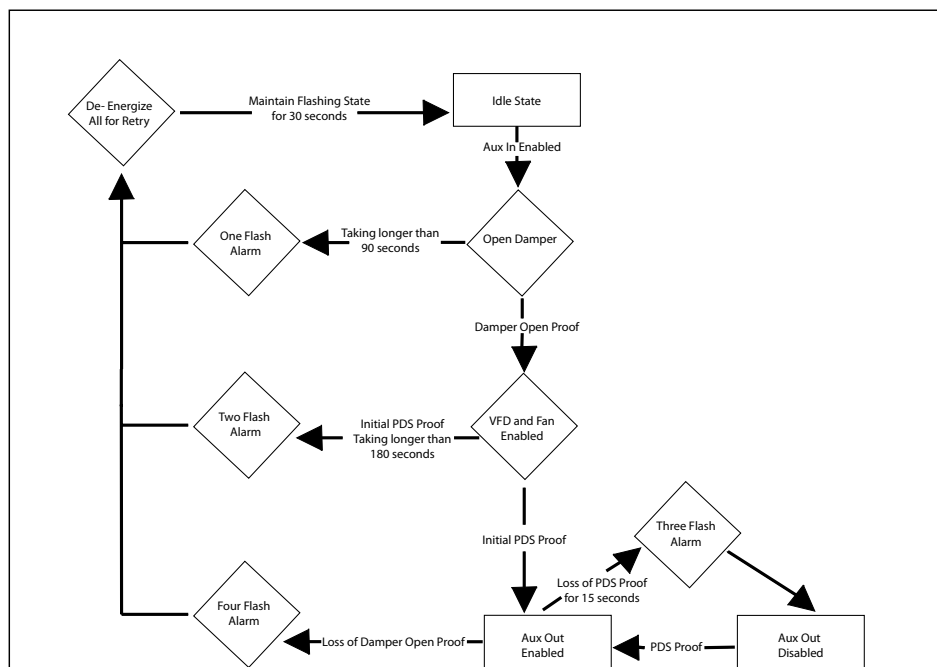

Stages

Flashes 1 - if damperprove does not close 90 seconds after auxin, go into alarm for 30 seconds, followed by a full retry

Flashes 2 - if initial pdsprove does not close 180 seconds after damperprove, go into alarm for 30 seconds, followed by a full retry

Flashes 3 - if pds loses proof for 15 seconds after initial pdsprove, auxouts de-energize, stay in alarm until pdsprove returns and auxout will re-energize

Flashes 4 - if at any point after auxout proves the damperprove is removed, the board immedialy goes into alarm for 30 seconds, followed by a full retry

Flashes 5 - *must have sw3 on* if pds is proved prior to auxin, board will go into alarm and no further states can be achieved until proof is removed

Start

1. A call for heat from the appliance energizes the ADC100 inputs at terminals 9 and 10.

Sequence

2. If a damper is connected, it begins to open. Once open, the damper prove contact closes (Terminals 16 and 17).
3. The ADC100 begins to ramp up the fan.
4. The Proven Draft Switch closes when adequate draft is achieved and ADC100 adjusts fan to speed setting on the potentiometer.
5. The ADC100 control releases the appliance for operation by closing dry contact between terminals 22 and 23 (and terminals 29 and 30).

Operating Sequence

Manual Mode:

1. Fan runs at a constant speed and can be adjusted during normal operation using the potentiometer.
2. If the Proven Draft Switch opens, a 15 second timing cycle starts.
3. If the Proven Draft Switch has not been made within 15 seconds, the auxiliary out contact opens and an alarm condition exists.
4. If the Proven Draft Switch closes, the control automatically resumes normal operation at set speed.

TROUBLESHOOTING

PROBLEM	SOLUTION
Appliance does not light within 20 seconds.	<p>If the appliance does not light within 20 seconds, the gas valve will lock out automatically. Turn off switch, wait 10 seconds, and try turning it on again.</p> <p>If there is still no ignition, turn off switch and visually inspect wiring harness for loose connections and check to be sure the gas supply is connected and all valves are open.</p> <p>If the appliance still does not ignite, check the spark igniter to be sure it is operating correctly. It should have a visible spark and make a clicking sound as it sparks.</p> <p>If no spark is seen, verify that all connections are tight and secure at the ignition control module. If it still fails to ignite, the draft proving system may not be activating. Contact a qualified technician to verify that the venting is clear, the exhaust fan is operational, and that the draft proving system is functioning properly. The system will not start the ignition sequence until draft is proven.</p>
Spark Igniter is working, but does not ignite the flame.	It will stop sparking after 11 seconds as a safety, and will then lock out the gas valve. Turn off the switch and try again. If it is still sparking with no ignition, contact a qualified technician.
The appliance ignites, but shuts down shortly after ignition.	<p>The flame sensor may not be registering proper flame strength. Turn the appliance on and visually inspect the spark ignition sequence. If the igniter is still sparking after the flame is burning, it may indicate that the flame sensor rod is not making proper contact with the flames. The flame sensor must be located directly in the flame to get the proper signal. A DC current is created by the flame on the rod that must be present to prove there is a flame or the valve will lock out. If the flame is not making direct contact with the flame sensor, contact a qualified technician to make necessary adjustments.</p> <p>If the flame sensor appears to be red hot and within the flames, yet the igniter keeps sparking, the sensor is not sensing the flame properly and the valve will lock out after 11 seconds. Verify that all electrical connections to the ignition module are tight and secure. If it still does not stay lit, contact a qualified technician.</p>
The flames appear light and lazy on the burner.	Visually compare flame to those shown in the Installing the Media section of this manual. There may be a reduction in gas pressure or a blockage to the venting. Contact a qualified technician to diagnose.

MAINTENANCE & CARE

Always use proper precautions and turn off fireplace before performing any maintenance.

Do not clean appliance when hot.

Clean the tempered glass with a basic household glass cleaner every 3 months to 1 year (depending on frequency of use). Never use abrasive cleaners or glass cleaner that contains ammonia, as it may etch the tempered glass.

Examination and inspection of the appliance, venting system, and all components including the burner, should be performed annually by a qualified service technician.

Examination and visual check of the burner & flame should be performed periodically to ensure proper operation. If the flame deviates greatly from the standard or if any portion of the burner has a large gap between flames, the burner orifices may need cleaning. Contact a qualified technician to diagnose, correct, and clean the burner orifices as needed.

Replacement of worn, broken, or non-functioning components should be left to a qualified service technician.

If glass panels suffer any type of impact, immediately cease use of fireplace until a qualified technician can assess the integrity of the panels and determine if they need replacement before continued use.

The area around the appliance must be kept clear and free from combustible materials, gasoline, and other flammable vapors and liquids.

Keep combustion and ventilation air flows unobstructed.

WARRANTY

ALL WARRANTIES EFFECTIVE DATE OF SHIPMENTS

The Warranty

Acucraft warrants the gas appliance to be free from defects in materials and workmanship at the time of manufacture. On all gas appliances, there is a **lifetime warranty** on the firebox. There is a **five-year warranty** on the main burner. A **one-year warranty** is given to the pilot burner, gas control valve, glass media and logs, and other gas components.

No Warranty

Acucraft does not warrant any finish or plating on the system or any part thereof. Glass and refractory lining are exempt from warranty as well.

Remedy and Exclusions

The coverage of this warranty is limited to all components of the gas appliance manufactured by Acucraft. If the components of the gas appliance covered by this warranty are found to be defective within the time stated. Acucraft, at its option, will replace or repair defective components of the gas appliance manufactured by Acucraft at no charge, and may also choose pay for reasonable labor costs incurred in repairing components requiring approval prior to work commencing. This warranty covers only parts and labor as provided above. In no case shall Acucraft be responsible for materials, components, or construction which are not manufactured or supplied by Acucraft, or for the labor necessary to install, repair or remove such materials, components or construction. All replacement or repair components will be shipped F.O.B. back to Acucraft. A warranty credit will be issued upon receipt and testing of defective parts.

Qualifications to the Warranty

The gas appliance warranty outlined above is further subject to the following qualifications:

- (1) The gas appliance must be installed in accordance with Acucraft installation instructions and local building codes. The warranty on this Acucraft gas appliance covers only the component parts manufactured by Acucraft. The use of components manufactured by others with the Acucraft gas appliance could create serious safety hazards, and may result in the denial of certification by recognized national safety agencies, and could be in violation of local building codes. This warranty does not cover any damages occurring from the use of any components not manufactured or supplied by Acucraft.
- (2) The Acucraft gas appliance must be subjected to normal use. The gas appliances are designed to burn gas only. Burning conventional fireplace fuels such as wood, coal or any other solid fuel will cause damage to the gas appliance, will produce excessive temperatures and will result in a fire hazard.

Limitations on Liability

It is expressly agreed and understood that Acucraft's sole obligation, and purchaser's exclusive remedy under this warranty, under any other warranty, expressed or implied, or in contract, tort or otherwise, shall be limited to replacement, repair, or refund, as specified above.

In no event shall Acucraft be responsible for any incidental or consequential damages caused by defect in its products, whether such damage occurs or is discovered before or after replacement or repair, and whether or not such damage is caused by Acucraft negligence. Some states do not allow the exclusion or limitation of incidental or consequential damages, so the above limitation or exclusion may not apply to you. The duration or any implied warranty with respect to this Acucraft gas appliance is limited to the duration of the foregoing warranty. Some states do not allow limitation on how long an implied warranty lasts, so the above may not apply to you.

Investigation of Claims against Warranty

- Acucraft reserves the right to investigate any and all claims against this warranty and to decide upon method of settlement.
- Acucraft is not responsible for work done without consent.
- Acucraft shall in no event be responsible for any warranty work done without first obtaining Acucraft's written consent.
- Resellers have no authority to alter this warranty.
- Acucraft employees and resellers have no authority to make any warranties nor to authorize any remedies in addition to or inconsistent with those stated above.

How to Register a Claim against Warranty

In order for any claim under this warranty to be valid, Acucraft must be notified of the claimed defect by emailing service@acucraft.com, as soon as reasonably possible after the defect is discovered. Claims against this warranty must include the date of installation, and a description of the defect.

In order to validate your warranty you must complete the warranty form at www.acucraft.com/warranty within thirty (30) days of receiving your fireplace. Without a warranty validation you will not be able to submit any warranty claims for your Acucraft appliance.



FIRE IS OUR PASSION

www.acucraft.com 888-317-6499

Acucraft Fireplaces
19672 172nd Street
Big Lake, MN 55309