



LISTING REPORT

For

Acucraft Fireplaces

19672 172nd Street
Big Lake, Minnesota 55309
USA

Date: December 11, 2017
Report No.: 14563-7G
Revision No.: 0
Project No.: 14563
Model No.: Custom Gas L-Shaped Fireplace
Product Type: Vented Gas Fireplace

Your Partner in Testing and Certification Inc.



205 – 8291 92 Street, Delta, BC
V4G 0A4, Canada
Phone: 604-247-0444
Fax: 604-247-0442
www.labtestcert.com

Date Issued:	Project No:	Client	Report No:	Revision No:
December 11, 2017	14563	Acucraft Fireplaces	14563-7G	0

TABLE OF CONTENTS

GENERAL TERMS..... 4
ALTERATION..... 8
MARKING..... 9
EXAMPLE MARKING LABEL 21
PRODUCT DESCRIPTION..... 24
FIGURES / DIAGRAMS 27
PICTURES 31
INSTALLATION AND OPERATING MANUAL..... 42
FACTORY PRODUCTION TESTS 85
TEST DATA SECTION 88
UNLISTED COMPONENTS REQUIRING RE-EVALUATION-N/A..... 90

SAMPLE

LISTING REPORT

Date Issued:	Project No:	Client	Report No:	Revision No:
December 11, 2017	14563	Acucraft Fireplaces	14563-7G	0

REPORT

Certification System	Type 3 (ISO / IEC Guide 67 clauses 6.2 and 6.3)
Scope	This report covers the evaluation of Acucraft Fireplaces direct vented gas fireplace, model Custom Gas L-Shaped Fireplace; for use with natural gas. The Custom Gas L-Shaped Fireplace is designed for indoor use only.
ICS Code	97.100.20
Report reference No.:	14563-7G

Note: By signing the below, both the Issuer and the Reviewer hereby declare to abide by the applicable LabTest policies:

- 1.) Statement of Independence # 3014 (LabTest Employees), or
- 2.) Independence, Impartiality, and Integrity #1039, clause 11 (Engineering Service Subcontractors).

Complied and Issued by: (print name and signature)	Derrick Southworth	
Date of issue:	December 11, 2017	
Reviewed by: (print name and signature)	Robert Grady	
Date of Review:	December 11, 2017	

<input checked="" type="checkbox"/> Testing Location (Name):	Acucraft Fireplaces
Address:	19672 172 nd Street, Big Lake, Minnesota 55309, USA
Testing By:	Derrick Southworth

Applicant's Name:	Acucraft Fireplaces
Contact Person:	Chris Maxson
Address:	19672 172 nd Street, Big Lake, Minnesota 55309, USA

Test specification	
Standard (Test Specification)	➤ ANSI Z21.50-2016 / CSA 2.22-2016 – Vented Decorative Gas Appliances
Conclusion	The submitted test item noted below was found to be in compliance with the above noted standard(s).

Test item description	Vented Gas Fireplace
Manufacture:	Acucraft Fireplaces
Model No.:	Custom Gas L-Shaped Fireplace
Ratings:	<ul style="list-style-type: none"> ➤ Natural Gas <ul style="list-style-type: none"> ➤ Maximum: 200,000 BTU/hr at 7" water column inlet supply pressure ➤ Electrical: 120 Vac, less than 2 Amps

LISTING REPORT

Date Issued:	Project No:	Client	Report No:	Revision No:
December 11, 2017	14563	Acucraft Fireplaces	14563-7G	0

GENERAL TERMS

Test items particulars:

The Acucraft Fireplaces' indoor and outdoor use direct vented gas fireplace, model Custom Gas L-Shaped Fireplace for use with natural gas or propane. The Custom Gas L-Shaped Fireplace designed to be installed with a single side outdoors and the other indoors. The Custom Gas L-Shaped Fireplace model must remain connected to a listed venting system as specified by manufacturer and in accordance with local codes.

Possible test case verdicts

Test case does not apply to the test object : N/A
 Test item does meet the requirement : Pass (P)
 Test item does not meet the requirement .. : Fail (F)

Testing

Conducted at Acucraft Fireplaces

Date of receipt of test item : October 24, 2017
 Date(s) of performance of test : October 24, 2017

File Transfer, testing conducted by

Certification Body (CB) :
 Report No. :
 Report Date :

General remarks

This report does not permit the use of the LC mark unless provided with Certificate of Conformity and Authorization Letter to Mark issued by LabTest Certification Inc.

This report shall not be reproduced except in full without the written approval of the testing laboratory. The test results presented in this report relate only to the item(s) tested.

(see remark #)" refers to a remark appended to the report.

"(see Annex #)" refers to an annex appended to the report.

- Throughout this report a comma is used as the decimal separator.
- Throughout this report a period is used as the decimal separator.

Note:

- Complies with CSA P.4.1 - Testing Method for Measuring Annual Fireplace Efficiencies
- Complies with CAN/CGA 2.17-M91 - Gas Fired Appliances for use at High Altitudes
- Shall be connected to a listed venting system as specified by manufacturer and in accordance with local codes.
- Designed for use indoors with natural gas only.
- Not to be used with solid fuel.

Report History:

- Rev. 0 – Issued December 11, 2017

Date Issued:	Project No:	Client	Report No:	Revision No:
December 11, 2017	14563	Acucraft Fireplaces	14563-7G	0

General Requirements and Definitions

The Applicant and Manufacturer have agreed to produce, test and label LabTest Certification Inc. listed products in accordance with the requirements of this Report. The Applicant and Manufacturer have also agreed to notify LabTest Certification Inc. and to request authorization in writing prior to using alternate parts, components or materials.

COMPONENTS

Components used shall be those listed in the LabTest report covering the products specified in the index including any amendments and/or revisions.

LISTING MARK

The LabTest listing mark applied to the products shall either be separable in form, such as labels purchased from LabTest, or on a product nameplate or other media only as specifically authorized by LabTest. Use of this listing mark is subject to the control of LabTest.

In the event that the LabTest representative identifies non-conformance(s) to any provision of this Report, the Applicant shall take one or more of the following actions:

- Correct the non-conformance(s).
- Remove the LabTest Certification Mark from non-conforming product.
- Contact the LabTest Certification Inc. office that issued this Report for additional instructions.

GENERAL DEFINITIONS

Representative samples of the subject project were examined and are described in the body of this report. Unless specifically stated otherwise, the following general definitions, terminology and construction details apply:

Asterisk: In "Certified*" the asterisk denotes that an SCC Accredited Certification Monogram appears in the components.

Asterisk: In "Listed*" the asterisk denotes that an OSHA Accredited NRTL Listing Monogram appears in the components.

Equivalent: The phrase "or equiv" denotes that an alternative equivalent component having similar mechanical and electrical characteristics may be used and, where the original component was Certified and/or Listed/Recognized, must be a Certified and/or Listed/Recognized component. Equivalent means that the component has equivalent mechanical and electrical characteristics and has no impact on the conformity of the product.

Construction Details: For specific construction details, reference shall be made to the following photographs and descriptions. All dimensions are approximate unless specified as exact or within a tolerance. In addition to the specific construction details described in this Report, the following general requirements also apply.

General Construction: The construction of the appliance shall be in accordance with reasonable concepts of safety, substantiality and durability. Component parts shall be well fitted and not show signs of becoming warped, bent, broken or otherwise damaged through normal use.

Displacement of Parts: Every part of the appliance shall be designed to be secure against displacement and constructed to maintain a fixed relationship between essential parts under normal and reasonable

Date Issued:	Project No:	Client	Report No:	Revision No:
December 11, 2017	14563	Acucraft Fireplaces	14563-7G	0

conditions of handling and usage. Simulated logs and/or coal pieces are a functional part of the burner and shall be secured in position.

Materials: Materials used in the construction of appliances shall have strength, durability, resistance to corrosion.

Exposed Edges: Exposed edges, which may come in contact with the operator's hand during normal adjustment, or usage should be smooth.

Joints: Joints of surfaces enclosing combustion products shall not depend primarily on cement for tightness and shall be durable and rigid construction, such as welded, brazed, machined and bolted, tongue-and-groove, slip, lap, or screw joint.

Threaded Parts: Bolts, nuts and screws employed in the assembly of the appliance shall not require the use of special tools for removal or replacement. Bolts, nuts, screws (except sheet-metal screws) and other threaded parts shall have threads conforming to the Standard for Unified Inch Screw Threads, ANSI/ASME B1.1 or the Standard for metric Screw Threads – M Profile, ANSI/ASME B1.13M.

Controls: All controls and accessories including automatic gas ignition systems, piezo-electric spark devices, manual gas valves, automatic valves, gas appliance regulators, pilot gas filters and draft hoods must be certified.

Internal Wirings: All primary, and grounding circuit conductors are CSA/UL certified TEW, TR-64, AWM SR-PVC or AWM XL-PVC, rated min 80°C, 300 VAC. All wiring is suitably routed and secured away from sharp edges and moving parts to prevent chafing of the insulation. Alternatively, additional insulation is provided where the wiring passes over sharp edges and through holes.

Grounding: The green or green/yellow insulated grounding conductor of the power supply cord terminates singly in a crimp type, closed loop connector, secured to the chassis by a min. No. 6 plated or non-ferrous threaded screw, nut and star washer (to ensure surface coating penetration).

Accessibility of Live Parts: All uninsulated live parts in primary circuitry are housed within a metal/plastic enclosure constructed such that any openings are not penetrable by the probe specified in the above-referenced Standard.

Markings: The unit is to be marked with the manufacturer's name or identifying symbol and address, model number, a distinctive number which will identify an individual appliance (serial number), electrical ratings, and cautionary markings where required. **Products for end-use in Canada may be required to have markings in both French and English. It is the responsibility of the Applicant to determine any such requirement and provide bilingual markings, where applicable, in accordance with the Provincial Regulatory Authorities.**

Installation, Operating and Safety Instructions: Instructions for the proper installation and safe use of this product are provided by the manufacturer. **Products for end-use in Canada may be required to have markings in both French and English. It is the responsibility of the Applicant to determine any such requirement and provide bilingual markings, where applicable, in accordance with the Provincial Regulatory Authorities.**

ELV: All references to "ELV" denote Extra Low Voltage (less than 240 VA and less than 42.4 V pk) energy limited secondary circuits.

LISTING REPORT

Date Issued:	Project No:	Client	Report No:	Revision No:
December 11, 2017	14563	Acucraft Fireplaces	14563-7G	0

ELV Wiring: All non-certified conductors and connectors in ELV sec circuits have insulation materials with a flammability rating of 94V-2 or better or are made of PVC, TFE, PTFE, FEP or Neoprene and are routed and secured away from contacting all primary circuitry.

Dimensions: All dimensions specified are approximations only. Unless stated otherwise, the least significant digit is uncertain by plus or minus one unit.

Polarization: Proper polarization is maintained throughout the equipment on polarized receptacle and load fittings where these devices are conductively connected to the supply.

Sleeving: All thermoplastic and other insulating tubing used in primary circuits are Certified/ULR, rated min 105°C, 300 V ac.

Crimp Connectors: All crimp type connectors used in primary, low voltage, secondary, and grounding circuits are Certified vinyl insulated and appropriately sized for the gauge of wire used. Any larger compression lugs are Certified, 600 V rated, and covered with heat shrink tubing if required.

Printed Circuit Boards (PCB): All PCB's are made of Glass base, epoxy resin, carry a Flame Rating of NEMA FR-4/G-10, and are min 1.6 mm thick. All have solder mask and component identification layer.

Segregation: Insulated conductors of different circuits are provided with spacing as specified in spacing above. Insulated conductors are positively maintained away from bare live parts of different circuits, sharp edges and heat producing components.

Soldered Connections: All connections are mechanically secured before soldering.

Strain Relief: Strain relief is to be provided for all conductors leaving an enclosure.

Date Issued:	Project No:	Client	Report No:	Revision No:
December 11, 2017	14563	Acucraft Fireplaces	14563-7G	0

ALTERATION

The manufacturer/applicant agrees to complete all below noted alterations prior to shipping and labeling products with the LC Certification Mark:

1. Unit shall be marked as with the marking noted in the Marking section.
2. Appliance Installation and Operating Instructions shall be provided with the applicable French verbiage as detailed in the Marking section of this report.

SAMPLE

Date Issued:	Project No:	Client	Report No:	Revision No:
December 11, 2017	14563	Acucraft Fireplaces	14563-7G	0

MARKING

Products for end-use in Canada may be required to have markings/instructions in both French and English. It is the responsibility of the Applicant to determine any such requirement and provide bilingual markings, where applicable, in accordance with the Provincial Regulatory Authorities.

Note: See page 17 of this report for Items unique to Canada.

Marking material shall be identified by class number and shall meet the following specifications. All metal marking materials shall be rustproof. All markings shall be suitable for application to surfaces upon which applied and shall demonstrate suitable legibility as specified in Clause 5.40, Marking material adhesion and legibility. The designation of any class of marking shall not preclude the use of marking of a lower number class.

Class I. Integral Marking

Marking that is embossed, cast, stamped, or otherwise formed in the part. This includes markings baked into an enameled surface.

Class IIA-1. Permanent Plate

Plate shall be made of metal having a minimum thickness of 0.012 in (0.30 mm), shall be securely attached by mechanical means, and shall comply with Clause 5.40, Marking material adhesion and legibility.

Class IIA-2. Permanent Plate

Plate shall be made of metal having a thickness of 0.006 to 0.012 in (0.15 to 0.30 mm), shall have mechanical attachment means at all corners with a maximum spacing of 6 in (152 mm) between mechanical fasteners, and shall comply with Clause 5.40, Marking material adhesion and legibility.

Class IIA-3. Permanent Plate

Plate shall be made of metal having a thickness less than 0.006 in (0.15 mm). Such plates shall be attached by means of non-water-soluble adhesive, which will comply with Clause 5.40, Marking material adhesion and legibility. These materials shall not be located on surfaces having temperatures exceeding 300 °F (149 °C) as determined during conduct of Clause 5.26, Wall, floor, and ceiling temperatures

Class IIA-4. Permanent Plate

Plate shall be made of pressure-sensitive metal foil requiring no solvent or activator, provided such plates comply with Clause 5.40, Marking material adhesion and legibility. These materials shall not be located on surfaces having temperatures exceeding 300 °F (149 °C) as determined during conduct of Clause 5.26, Wall, floor, and ceiling temperatures.

Class IIIA-1. Permanent Label

Label shall be made of material not adversely affected by water, shall be attached by means of non-water-soluble adhesive, and shall comply with Clause 5.40, Marking material adhesion and legibility. These materials shall not be located on surfaces having temperatures exceeding 300 °F (149 °C) as determined during conduct of Clause 5.26, Wall, floor, and ceiling temperatures.

Class IIIA-2. Permanent Label

Label shall be made of material not adversely affected by water, shall be attached by means of non-water-soluble adhesive, and shall comply with Clause 5.40, Marking material adhesion and legibility.

Date Issued:	Project No:	Client	Report No:	Revision No:
December 11, 2017	14563	Acucraft Fireplaces	14563-7G	0

These materials shall not be located on surfaces having temperatures exceeding 175 °F (79.5 °C) as determined during conduct of Clause 5.26, Wall, floor, and ceiling temperatures.

Class IIIB. Waterproof Marking

Marking shall be printed directly on the part with waterproof marking not adversely affected by a temperature of 175 °F (79.5 °C). This marking shall not be used on surfaces having temperatures exceeding 175 °F (79.5 °C) as determined during conduct of Clause 5.26, Wall, floor, and ceiling temperatures.

Class IIIC. Waterproof Label

Label shall be made of material not soluble in water and may use water-soluble adhesive for attachment means.

Class IV. Non-waterproof Label

Label shall be made of material that may be soluble in water and may use water-soluble adhesive for attachment means.

Class V. Printed Marking

Marking shall be clear and prominent and may be applied directly by any printing means.

Class VI. Attached Tags

Rating plate(s)

Each appliance shall bear a plate, or a combination of plates in proximity, of Class IIIA marking material located so as to be easily read when the appliance is in a normally installed position. A rating plate(s) applied to the inner surface of a control compartment door is considered acceptable. The following information shall appear on the plate(s):

- a) type of appliance.
- b) on an appliance suitable for use only with a vent damper device:
 "For use only with automatic vent damper device Part No. _____. Follow installation instructions."
- c) on an appliance suitable for use with or without a vent damper device:
 "May be used with automatic vent damper device Part No. _____. Follow installation instructions."
- d) on an appliance where the trim panel assembly forms part of the draft hood relief mechanism:
 "For use only with trim kit(s) Part No(s). _____. Follow installation instructions."
- e) the manufacturer's or distributor's name and location.
- f) the manufacturer's or distributor's model designation of the appliance.
- g) a distinctive number that will identify an individual appliance.
- h) the manufacturer's normal hourly Btu input rating and manifold pressure in inches water column.
- i) type of gas for which equipped: Natural or Propane
- j) minimum permissible gas supply pressure for purpose of input adjustment.
- k) the statement: "Vented Gas Fireplace Not for Use with Solid Fuel."

The size of the lettering used for this marking shall be Vogue boldfaced upper case type, or equivalent, having a minimum letter height of 0.100 in (2.54 mm).* The minimum vertical spacing between lines of type shall be 0.066 in (1.67 mm).†

* This letter height measurement corresponds to 10-point type.

† This line spacing measurement corresponds to 2-point leading.

Date Issued:	Project No:	Client	Report No:	Revision No:
December 11, 2017	14563	Acucraft Fireplaces	14563-7G	0

- l) identification of this Standard by indicating either the edition of the standard, or the most recent effective addenda thereto, with one of the following markings:
 - “ANS Z21.50-(year) • CSA 2.22-(year) Vented Gas Fireplaces;”
 - “ANS Z21.50a-(year) • CSA 2.22a-(year) Vented Gas Fireplaces;” or
 - “ANS Z21.50b-(year) • CSA 2.22b-(year) Vented Gas Fireplaces.”
- m) electrical rating-voltage, frequency (Hz), and total input in amperes. If the total input of all components is less than 12 amperes, the input marking may optionally be shown as “less than _____ amperes.”*
 - * *This amperage rating shall be equal to or greater than the total input in amperes.*
- n) symbol of the organization making the tests for compliance with this Standard.
- o) where applicable [see Clause 4.27.3g)], the statement: “FOR USE WITH GLASS DOORS CERTIFIED WITH THE APPLIANCE ONLY” or “NOT FOR USE WITH GLASS DOORS.”
- p) on direct vent gas appliances for manufactured home (USA only) or mobile home installation convertible for use with natural gas and liquefied petroleum (propane) gases, see Clause 1.1c), this marking shall be as follows:
 - “For natural gas when equipped with No. _____ drill size orifice.”
 - “For propane when equipped with No. _____ drill size orifice.”
 - (Each orifice shall be clearly identified with regard to the gas for which it will be used and the orifice size shall be indicated on the spud or hood. Also see Clause 4.9.5).
- q) a direct vent gas appliance for manufactured home (USA only) or mobile home aftermarket installation for use with natural gas only or liquefied petroleum (propane) gases only, shall be marked:
 - “This appliance is only for use with the type of gas indicated on the rating plate and may be installed in an aftermarket, permanently located, manufactured home (USA only) or mobile home where not prohibited by local codes. See owner’s manual for details. This appliance is not convertible for use with other gases, unless a certified kit is used.”
- r) a direct vent appliance for manufactured home (USA only) or mobile home aftermarket installation convertible for use with natural gas and liquefied petroleum (propane) gases [see Clause 1.1c)] shall be marked:
 - “This appliance is only for use with the type(s) of gas indicated on the rating plate and may be installed in an aftermarket, permanently located, manufactured home (USA only) or mobile home, where not prohibited by local codes. See owner’s manual for details. This appliance is supplied with a conversion kit.”
- s) the information on the instruction plate may be combined with the information on the rating plate.
 - At least the following information shall appear on a single plate permanently affixed to the principle (main) assembly of the appliance:
 - i) Manufacturer’s or distributor’s name;
 - ii) Manufacturer’s or distributor’s model number of the appliance;
 - iii) Manufacturer’s normal input rating;
 - iv) Type of gas for which equipped and manufacturer’s recommended manifold pressure; and
 - v) Symbol of the organization making the examination for compliance with this Standard.
- t) Where applicable, “For use only with barrier(s) Part No(s) _____. Follow installation instructions.”

Instructions to put the fireplace in operation

Each appliance shall bear a single label or a series of adjacent labels of Class IIIB marking with letters on a contrasting background, located on or adjacent to the controlling device or in an equally conspicuous position where the instructions can be easily read by the operator during the lighting/operating and shutdown procedures.

Date Issued:	Project No:	Client	Report No:	Revision No:
December 11, 2017	14563	Acucraft Fireplaces	14563-7G	0

Where a series of labels is used, they shall:

- be capable of being reviewed simultaneously (in the same plane) in the sequence as shown in Annex E, F, or G, as applicable; and
- not be separated from each other by more than one inch.

The label(s) may be on the interior of a removable panel that provides access to the gas controls.

A separate means may be provided for mounting the lighting/operating instructions label(s). This means shall be permanently attached to the appliance in a manner such that, when lighting the appliance, the lighting/operating instructions can be easily read without detachment from the appliance.

If the above label(s) is not visible on the appliance when all panels are in place, a Class IIIA marking shall be affixed on the exterior of the appliance in a location where it can be easily read when the appliance is installed at the minimum clearances for which the appliance is to be listed. This marking shall indicate where the lighting/operating instructions are to be found.

On an appliance of such design that space does not permit proper location of these instructions, they may be furnished on a metal tag attached to the appliance.

The lighting/operating instructions label(s) specified in Clause 4.28.3 shall contain at least the following:

- for an appliance equipped with a continuous (piloted) ignition system, as outlined in Annex E, Outline of lighting instructions for appliances equipped with a continuous pilot;
- for an appliance equipped with an intermittent pilot or interrupted pilot ignition system, as outlined in Annex F, Outline of operating instructions for appliances equipped with intermittent pilot or interrupted pilot systems;
- for an appliance equipped with a direct ignition system, as outlined in Annex G, Outline of operating instructions for appliances equipped with direct ignition systems.

The statements in quotes in the above referenced annexes shall be worded as shown in the applicable annex.

The physical specifications of the lighting/operating instructions label(s) specified in Clause 4.28.3 shall be as follows:

- Each of the three sections shall be boxed by a red border, the top dimensions being a minimum $\frac{1}{4}$ in (6.4 mm) solid red line.
The solid red line shall be broken to show the title of these three sections on a white background as shown in Figures E.1, F.1, or G.1, as applicable.
- The titles of each section shall be black boldfaced type having a minimum letter height of 0.100 in (2.54 mm)* and located within the top border line.
- The word "WARNING" shall be black boldfaced type having a minimum letter height of 0.100 in (2.54 mm)*
** This letter height measurement corresponds to 10-point type.*
- The text of the label(s) shall be black boldfaced letters on a white background having a minimum uppercase letter height of 0.080 in (2.03 mm)* with a minimum vertical spacing between lines of type of 0.038 in (0.96 mm). † Lowercase letters shall be compatible with the uppercase letter size specification.
** This letter height measurement corresponds to 8-point type.*
† This line spacing measurement corresponds to 0-point leading.
- Unless the type sizes used of (b), (c), and (d) above are at least 0.140 in (3.56 mm), 0.120 in

Date Issued:	Project No:	Client	Report No:	Revision No:
December 11, 2017	14563	Acucraft Fireplaces	14563-7G	0

(3.05 mm), and 0.100 in (2.54 mm), respectively, the instruction specified in Clause 4.27.2d) shall be shown in these larger type sizes.

If the appliance does not provide a surface area adequate to affix the prescribed label, which is accessible and visible after installation, the label size may be reduced in proportion to available surface area.

The maximum reduction permitted shall be:

- i) Reduce $\frac{1}{4}$ in (6.4 mm) solid red line to $\frac{1}{8}$ in (3.2 mm);
- ii) Reduce 0.100 in (2.54 mm) letter height measurement to 0.080 in (2.03 mm);
- iii) Reduce 0.080 in (2.03 mm) letter height measurement to 0.060 in (1.5 mm); and
- iv) Reduce 0.038 in (0.97 mm) line spacing measurement to 0.024 in (0.61 mm).

Note: *The allowable reduced sizing is 64 percent of prescribed sizing.*

Instruction plate

Each appliance shall bear a Class IIIB marking with letters on a contrasting background, located adjacent to the controlling device or in an equally conspicuous position where the instructions can be easily read. These instructions shall include the following in a form which can be easily understood.

- a) "CAUTION: Hot while in operation. Do not touch. Severe burns may result. Keep children, clothing, furniture, gasoline and other liquids having flammable vapors away."
or
- b) "CAUTION: Hot while in operation. Do not touch. Severe burns may result. Keep children, clothing and furniture away."
- c) "CAUTION: Keep gasoline and other liquids having flammable vapors away."
- d) The statement, "Keep burner and control compartment clean. See installation and operating instructions accompanying appliance."

On an appliance of such design that space does not permit proper location of these instructions, they may be furnished on a metal tag attached to the appliance.

The word "CAUTION" shall be in letters having a minimum height of 0.240 in (6.09 mm).* The remainder of the wording shall be in letters having a minimum height of 0.120 in (3.04 mm) with a minimum vertical spacing between lines of 0.046 in (1.16 mm).† Letters are to be on a contrasting background.

* *This letter height measurement corresponds to 24-point type.*

† *These line height and line spacing measurements correspond to 12-point type.*

Installation marking

Each appliance shall bear:

- a) a marking on Class III marking material located on an exterior surface, which will be visible at the time of installation stating: "This appliance must be installed in accordance with local codes, if any; if none, follow ANSI Z223.1/NFPA 54, or CSA B149.1."
- b) When gas flow controls are not furnished assembled on the appliance, a Class VI marking on the control subassembly shall indicate assembly to the appliance.
- c) a marking on Class III marking material located on an exterior surface adjacent to the flue collar stating that the appliance must be properly connected to a venting system in accordance with the manufacturer's installation instructions.
- d) a Class V marking specifying the vent or vents for use with the appliance indicating the minimum and maximum vent lengths.
- e) for a direct vent gas fireplace for manufactured home (USA only) or mobile home OEM installation:

Date Issued:	Project No:	Client	Report No:	Revision No:
December 11, 2017	14563	Acucraft Fireplaces	14563-7G	0

“This appliance must be installed in accordance with the Standard for *Manufactured Homes*, CAN/CSA Z240 MH Series, or with the *Manufactured Home Construction and Safety Standard, Title 24 CFR, Part 3280*, or when such a standard is not applicable, the *Standard for Fire Safety Criteria for Manufactured Home Installations, Sites and Communities*, NFPA 501A.”

- f) in cases where sections of the venting system of direct vent appliances for manufactured home (USA only) or mobile home installation have been removed or not installed for transporting the manufactured home (USA only) or mobile home, a Class V marking shall be attached and shall state: “Sections of the venting system have not been installed. WARNING - Do not operate the appliance until all sections have been assembled and installed in accordance with the manufacturer's instructions.”
- g) for a gas fireplace insert, a Class IIA-1 marking to be supplied with the gas fireplace insert and attached to the fireplace in which the gas fireplace insert is to be installed stating: “WARNING. This fireplace has been converted for use with a gas fireplace insert only and cannot be used for burning wood or solid fuels unless all original parts have been replaced, and the fireplace re-approved by the Authority Having Jurisdiction.”
- h) for a gas fireplace insert, a Class IV marking stating the minimum size fireplace into which the gas fireplace insert can be installed: i.e., height and width of front opening, depth, and minimum chimney flue size.
- i) for a gas fireplace insert, a Class IV marking, visible at the time of installation stating: “WARNING: Failure to install this appliance per the manufacturer's instructions or failure to use only parts specifically approved with this appliance may result in property damage or personal injury.”

For appliances having a fast-acting thermocouple, a Class IIIC WARNING label shall be attached to the fast-acting thermocouple adjacent to the valve connection stating:

“WARNING: Fire or explosion hazard. Can cause property damage, severe injury or death.

“This is a fast-acting thermocouple. Replace it only with another fast-acting thermocouple specified by the appliance manufacturer. Refer to the manual for the part number.”*

* *Black boldfaced type with a minimum letter height of 0.1 inch (2.5 mm).*

A label of Class IIIC marking material shall, when practical, be affixed to the appliance in a conspicuous location by the manufacturer. When not practical, this label shall be supplied by the manufacturer with explicit instructions to affix the label in a conspicuous location adjacent to the appliance. This label shall include the following information:

“WARNING: Improper installation, adjustment, alteration, service, or maintenance can cause injury or property damage. Refer to the owner's information manual provided with this appliance. For assistance or additional information, consult a qualified installer, service agency, or the gas supplier.”

Clearance marking

Each appliance shall bear a marking on Class III marking material, located as specified in Clause 4.28.2, stating the minimum clearances from spacers/standoffs or surfaces to combustible construction for all appliance and vent surfaces. The marking for clearances shall indicate that the left and right sides are determined when facing the front of the appliance.

Date Issued:	Project No:	Client	Report No:	Revision No:
December 11, 2017	14563	Acucraft Fireplaces	14563-7G	0

An appliance that requires clearances from any type of construction for serviceability or proper operation shall bear a marking on Class III marking material, located on the surface(s) requiring such clearance, indicating the minimum distance required.

In addition, each appliance for installation recessed within combustible construction shall bear a Class V marking specifying the depth to which it may be recessed.

For an appliance with specified clearances from projections above the appliance, the marking shall indicate the minimum vertical clearance from the projection and the maximum horizontal extension of the projection over the appliance. (See Figure 2, Test room configuration.)

For an appliance equipped for use only at altitudes 0-2000 ft (0-610 m), the rating plate or a plate of Class IIIA marking material attached adjacent thereto shall state:

“This appliance equipped only for altitudes 0-2000 ft (0-610 m).”

The carton containing an automatic intermittent pilot ignition system for field installation shall be marked with at least the following:

- a) the manufacturer's name and address;
- b) the manufacturer's model number or other designation;
- c) the appliance manufacturer's name and the model number for which the automatic intermittent pilot ignition system is for use on as follows:
 “FOR USE WITH _____ (Manufacturer) _____ (Model No.) ONLY.”
- d) the type of gas for which equipped;
- e) the rated supply voltage;
- f) the symbol of the organization making the tests for compliance with this Standard; and
- g) a statement that the system must be installed by a qualified installing agency.

Where the trim panel assembly forms part of the draft hood relief mechanism, the trim assembly shall bear a Class IIIB marking in a conspicuous location, visible at the time of installation, indicating the following (see Clause 4.27.5):

“Trim Kit Part No. _____. This trim assembly is a component part of the draft hood.
Follow installation instructions.”

A vent damper device that is not an integral part of the draft hood shall bear a plate of Class II marking material on which shall appear the following:

- a) the appliance manufacturer's part number of the vent damper device;
- b) a distinctive number that will identify each individual vent damper device or a separate date code marking.

If a separate date code marking is used, it shall consist of at least four consecutive digits determined as follows:

- i) the first and second digits shall indicate the calendar year in which the device is manufactured (e.g. 06 for 2006);
- ii) the third and fourth digits shall indicate the week in which the device was manufactured (e.g., 03 for the third week of the year). For the purpose of this marking, a week shall begin at 0001 hours on Sunday and end at 2400 hours on Saturday. A date code may be used for more than one week; however, it shall not be used for more than four consecutive weeks, nor for

Date Issued:	Project No:	Client	Report No:	Revision No:
December 11, 2017	14563	Acucraft Fireplaces	14563-7G	0

more than two weeks into the next calendar year.

Additional numbers, letters, or symbols may follow the four-digit number specified in Clause 4.28.16b)i) and b)ii). If additional numbers are used, they must be separated from the date code.

- c) the inlet, outlet or direction of vent gas flow; and
- d) on mechanically actuated vent damper devices, type and range of motive power that will permit normal functioning of the vent damper device.

A vent damper device that is not an integral part of the draft hood shall bear a Class III marking attached to the vent damper device or a marking on the carton in which it is supplied, stating clearly and legibly:

“WARNING — Follow instructions for proper installation.”

The word “WARNING” shall be in letters having a minimum height of 0.240 in (6.09 mm).* The remainder of the warning shall be in letters having a minimum height of 0.120 in (3.04 mm) with a minimum vertical spacing between lines of 0.046 in (1.16 mm).†

* This letter height measurement corresponds to 24-point type.

† These line height and line spacing measurements correspond to 12-point type

Instruction plate

- Δ For a glass fronted gas appliance where the temperature of the outside glass viewing area surface exceeds the limits specified in Clause 5.13.2, the following graphic danger and statement shall be shown on a Class IIIA-2 Permanent Label.

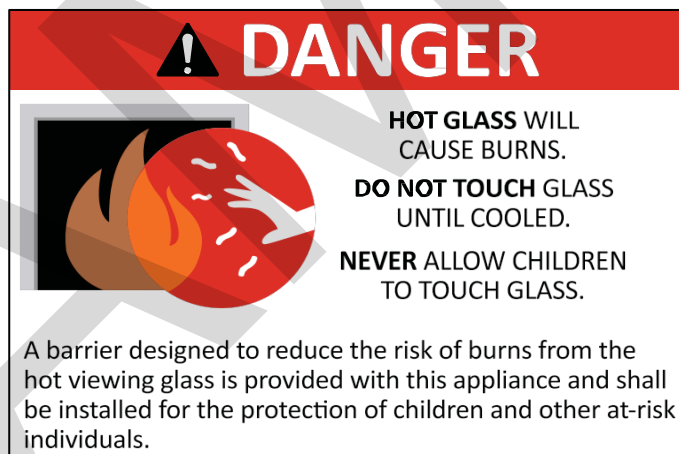

The Danger letter-type shall be a sans-serif font with a minimum letter height of the following:

- a) The symbol/word, “⚠ DANGER” shall be boldfaced type having a minimum uppercase letter height of 0.498 in (12.65 mm)†.
- b) The words as shown above, in the boxed statement shall be boldfaced type having a minimum uppercase letter height of 0.120 in (3.05 mm). The minimum vertical spacing between lines of type shall be 0.046 in (1.17 mm).* Lowercase letters shall be compatible with the uppercase letter size specifications.
- c) The word DANGER shall be in white letters on a red background.

* This letter height measurement corresponds to 24-point type.

† These line height and line spacing measurements correspond to 12-point type.

Date Issued:	Project No:	Client	Report No:	Revision No:
December 11, 2017	14563	Acucraft Fireplaces	14563-7G	0

Items Unique to Canada – French Translations where applicable

Clause	English	French
4.27.6d)	"If the factory-built fireplace has no gas access hole(s) provided, an access hole of 1.5 in (38.1 mm) or less may be drilled through the lower sides or bottom of the firebox in a proper workmanship like manner. This access hole must be plugged with non-combustible insulation after the gas supply line has been installed."	«Si le foyer préfabriqué ne comporte pas d'orifices d'amenée du gaz, un orifice d'au plus 37,5 mm (1,5 po) peut être pratiqué, selon les règles de l'art, dans la partie inférieure des parois ou au fond de la chambre de combustion. Cet orifice doit être obturé au moyen d'isolant incombustible une fois la conduite de gaz en place.»
4.27.7b)	"Clearances are in accordance with local installation codes and the requirements of the gas supplier."	«Les dégagements sont conformes aux codes d'installation locaux et aux exigences du fournisseur de gaz.»
4.27.8g)	"Damper must be in open position when appliance main burner(s) is operating."	«Le registre doit être en position ouverte lorsque le ou les brûleurs principaux de l'appareil fonctionnent.»
4.28 Marking		
4.28.2b)	"For use only with automatic vent damper device Part No. _____. Follow installation instructions."	«Pour utilisation avec un registre de conduit d'évacuation automatique no _____ seulement. Suivre les instructions d'installation.»
4.28.2c)	"May be used with automatic vent damper device Part No. _____. Follow installation instructions."	«Peut être utilisé avec le registre de conduit d'évacuation automatique no _____. Suivre les instructions d'installation.»
4.28.2d)	"For use only with trim kit(s) Part No(s). _____. Follow installation instructions."	«Utiliser uniquement avec la trousse de garniture no _____. Suivre les instructions d'installation.»
4.28.2k)	"Vented decorative gas appliance: not a source of heat; not for use with solid fuel."	«Appareil à gaz décoratif à évacuation: n'est pas une source de chaleur; ne convient pas aux combustibles solides.»
4.28.2l)	"ANS Z21.50-(year) • CSA 2.22-(year) Vented Decorative Gas Appliances"	«ANS Z21.50-(année) • CSA-2.22-(année), Appareil à gaz décoratif à évacuation»
4.28.2m)	"less than ____ amperes."* * This amperage rating shall be equal to or greater than the total input in amperes.	«moins de ____ ampères.»* * Cette puissance nominale doit être égale ou supérieure à la puissance d'entrée totale en ampères.
4.28.2o)	"FOR USE WITH GLASS DOORS CERTIFIED WITH THE APPLIANCE ONLY" or "NOT FOR USE WITH GLASS DOORS."	«POUR UTILISATION UNIQUEMENT AVEC LES PORTES EN VERRE CERTIFIÉES AVEC L'APPAREIL» ou «NE PAS UTILISER AVEC DES PORTES EN VERRE»
4.28.2p)	"For natural gas when equipped with No. _____ drill size orifice." "For propane when equipped with No. _____ drill size orifice."	«Convient au gaz naturel quand l'appareil est muni d'un injecteur de diamètre no. _____.» «Convient au propane quand l'appareil est muni d'un injecteur de diamètre no. _____.»

Date Issued:	Project No:	Client	Report No:	Revision No:
December 11, 2017	14563	Acucraft Fireplaces	14563-7G	0



Clause	English	French
4.28.2q)	"This appliance is only for use with the type of gas indicated on the rating plate and may be installed in an aftermarket, permanently located, manufactured home (USA only) or mobile home where not prohibited by local codes. See owner's manual for details. This appliance is not convertible for use with other gases, unless a certified kit is used."	«Cet appareil doit être utilisé uniquement avec le type de gaz indiqué sur la plaque signalétique. Cet appareil peut être installé dans une maison préfabriquée ou mobile (É.-U. seulement) installée à demeure si les règlements locaux le permettent. Voir la notice de l'utilisateur pour plus de renseignements. Cet appareil ne peut pas être utilisé avec d'autres gaz sauf si une trousse de conversion certifiée est fournie.»
4.28.2r)	"This appliance is only for use with the type(s) of gas indicated on the rating plate and may be installed in an aftermarket, permanently located, manufactured home (USA only) or mobile home, where not prohibited by local codes. See owner's manual for details. This appliance is supplied with a conversion kit."	«Cet appareil doit être utilisé uniquement avec les types de gaz indiqués sur la plaque signalétique et peut être installé dans une maison préfabriquée (É.-U. seulement) ou mobile installée à demeure si les règlements locaux le permettent. Voir la notice de l'utilisateur pour plus de renseignements. Une trousse de conversion est fournie avec cet appareil.»
4.28.2t)	"For use only with barrier(s) Part No(s) _____. Follow installation instructions."	«Utiliser uniquement avec l'écran no _____. Suivre les instructions d'installation.»
4.28.6a)	"CAUTION: Hot while in operation. Do not touch. Severe burns may result. Keep children, clothing, furniture, gasoline and other liquids having flammable vapors away."	«ATTENTION: L'appareil est chaud lorsqu'il fonctionne. Ne pas toucher l'appareil. Risque de brûlures graves. Surveiller les enfants. Garder les vêtements, les meubles, l'essence ou autres liquides produisant des vapeurs inflammables loin de l'appareil.»
4.28.6b)	"CAUTION: Hot while in operation. Do not touch. Severe burns may result. Keep children, clothing and furniture away." "CAUTION: Keep gasoline and other liquids having flammable vapors away."	«ATTENTION. L'appareil est chaud lorsqu'il fonctionne. Ne pas toucher l'appareil. Risque de brûlures graves. Surveiller les enfants. Garder les vêtements et les meubles loin de l'appareil.» «ATTENTION. Garder l'essence ou autres liquides produisant des vapeurs inflammables loin de l'appareil.»
4.28.6d)	"Keep burner and control compartment clean. See installation and operating instructions accompanying appliance."	«S'assurer que le brûleur et le compartiment des commandes sont propres. Voir les instructions d'installation et d'utilisation qui accompagnent l'appareil.»
4.28.7a)	"This appliance must be installed in accordance with local codes, if any; if none, follow ANSI Z223.1/NFPA 54, or CSA B149.1."	«Installer l'appareil selon les codes ou règlements locaux, ou, en l'absence de tels règlements, selon les codes d'installation ANSI Z223.1/NFPA 54 ou CSA-B149 en vigueur.»
4.28.7e)	"This appliance must be installed in accordance with <i>Manufactured Homes</i> , CAN/CSA Z240 MH Series, or with the	«Installer l'appareil selon la norme CAN/CSA-Z240, <i>Série MM sur les maisons mobiles</i> , ou la norme 24 CFR, <i>Part 3280</i> ,

Date Issued:	Project No:	Client	Report No:	Revision No:
December 11, 2017	14563	Acucraft Fireplaces	14563-7G	0

Clause	English	French
	<i>Manufactured Home Construction and Safety Standard, Title 24 CFR, Part 3280, or when such a standard is not applicable, the Standard for Fire Safety Criteria for Manufactured Home Installations, Sites and Communities, NFPA 501A."</i>	<i>Manufactured Home Construction and Safety Standard. Si ces normes ne sont pas pertinentes, utiliser la norme NFPA 501A, Fire Safety Criteria for MANufactured Home Installations, Sites and Communities.»</i>
4.28.7f)	"Sections of the venting system have not been installed. WARNING - Do not operate the appliance until all sections have been assembled and installed in accordance with the manufacturer's instructions."	«Des sections du système d'évacuation n'ont pas été installées. AVERTISSEMENT - Ne pas utiliser l'appareil tant que toutes les sections n'ont pas été assemblées et installées selon les instructions du fabricant.»
4.28.7g)	"WARNING. This fireplace has been converted for use with a gas fireplace insert only and cannot be used for burning wood or solid fuels unless all original parts have been replaced, and the fireplace re-approved by the Authority Having Jurisdiction."	«AVERTISSEMENT: Ce foyer a été converti pour utilisation avec un foyer au gaz encastrable et ne peut être utilisé pour brûler du bois ou d'autres combustibles solides à moins que toutes les pièces d'origine aient été remplacées et que le foyer ait été approuvé de nouveau par l'autorité compétente.»
4.28.7i)	"WARNING: Failure to install this appliance per the manufacturer's instructions or failure to use only parts specifically approved with this appliance may result in property damage or personal injury."	«AVERTISSEMENT : Risque de dommages ou de blessures si l'appareil n'est pas installé selon les instructions du fabricant ou si des pièces autres que celles spécifiquement approuvées avec cet appareil sont utilisées.»
4.28.8	"WARNING: Fire or explosion hazard. Can cause property damage, severe injury or death. "This is a fast-acting thermocouple. Replace it only with another fast-acting thermocouple specified by the appliance manufacturer. Refer to the manual for the part number."	«AVERTISSEMENT : Risque d'incendie ou d'explosion. Peut entraîner des dommages matériels, des blessures graves ou la mort.» «Ceci est un thermocouple rapide. Peut être remplacé uniquement par un autre thermocouple rapide spécifié par le fabricant de l'appareil. Veuillez consulter à la notice pour le numéro de pièce.»
4.28.9	"WARNING: Improper installation, adjustment, alteration, service or maintenance can cause injury or property damage. Refer to the owner's information manual provided with this appliance. For assistance or additional information, consult a qualified installer, service agency or the gas supplier."	«AVERTISSEMENT: Une installation, un réglage, une modification, une réparation ou un entretien mal effectué peut causer des dommages matériels ou des blessures. Voir la notice de l'utilisateur qui accompagne l'appareil. Pour de l'aide ou des renseignements supplémentaires, consultez un installateur, un technicien agréé ou le fournisseur de gaz.»
4.28.12	"This appliance equipped only for altitudes 0-2000 ft (0-610 m)."	«Cet appareil peut être utilisé à des altitudes comprises entre 0 et 610 mètres (0 et 2000 pieds) seulement.»
4.28.14c)	"FOR USE WITH _____ (Manufacturer) _____ (Model No.) ONLY."	«POUR UTILISATION AVEC _____ (fabricant) _____ (no modèle) SEULEMENT»

LISTING REPORT

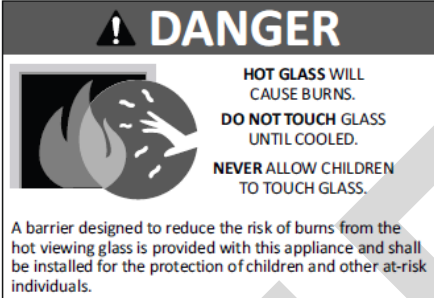
Date Issued:	Project No:	Client	Report No:	Revision No:
December 11, 2017	14563	Acucraft Fireplaces	14563-7G	0

Clause	English	French
4.28.15	"Trim Kit Part No. _____. This trim assembly is a component part of the draft hood. Follow installation instructions."	«Trousse de garniture no. _____. Cette garniture est un élément de la hotte de tirage. Suivre les instructions d'installation.»
4.28.17	"WARNING — Follow instructions for proper installation."	«AVERTISSEMENT. Suivre les instructions pour assurer une bonne installation.»
4.28.19	 <p>A barrier designed to reduce the risk of burns from the hot viewing glass is provided with this appliance and shall be installed for the protection of children and other at-risk individuals.</p>	 <p>L'écran pare-étincelles fourni avec ce foyer réduit le risque de brûlure en cas de contact accidentel avec la vitre chaude et doit être installé pour la protection des enfants et des personnes à risques.</p>

To avoid any misunderstanding, market and subject areas of the accredited scope covered by the LabTest Certification Mark must be indicated as shown below.



Conforms to: ANSI Z21.50-2016 / CSA 2.22-2016

Note: Jurisdictions in Canada may require markings to be also in French. It is the responsibility of the Customer to provide bilingual marking, where applicable, in accordance with the requirements of the Provincial Regulatory Authorities. It is the responsibility of the Customer to determine this requirement and have bilingual wording added to the "Markings".

LISTING REPORT

Date Issued:	Project No:	Client	Report No:	Revision No:
December 11, 2017	14563	Acucraft Fireplaces	14563-7G	0

EXAMPLE MARKING LABEL

Rating Plate:

MANUFACTURER: VENTED GAS FIREPLACE Serial #/En Série: 0925 Acucraft Fireplaces MODEL/ MODELE: Acucraft Custom Gas L-Shaped Fireplace 19672 172nd St Big Lake, MN 55308 (763) 263-3156	
GAS TYPE / TYPE DE GAZ: Natural Gas (Gaz naturel) INPUT RATING (ENTRÉE NOTE) (Btu/hr) 0-810m: 200,000 ORIFICE SIZE (DIMENSIONS DE L'ORIFICE) (DMS) 0-810m: L INPUT RATING (ENTRÉE NOTE) (Btu/hr) 810-1370m: 200,060 ORIFICE SIZE (DIMENSIONS DE L'ORIFICE) (DMS) 810-1370m: L MANIFOLD PRESSURE (PRESSION D'ADMISSION) (in. wolkPa): 3.5(0.9) MINIMUM INLET PRESSURE (MINIMUM PRESSION D'ENTRÉE) (in. wolkPa): 7.0(1.74) ELECTRICAL (ÉLECTRIQUE) 120 Vac, less than 2 Amps (Moins de 2 amperes)	
VENTED GAS FIREPLACE. NOT FOR USE WITH SOLID FUEL. NOT FOR USE WITH GLASS DOORS. ÉVACUATION FOYER DE GAZ. NE PAS UTILISER AVEC DES COMBUSTIBLES SOLIDES. NE PAS UTILISER AVEC PORTES EN VERRE.	
Follow installation instruction. Suivez les instructions d'installation.	Minimum clearances to combustibles: Unit to back wall of enclosure: 2 inches Unit to sidewall of enclosure: 2 inches Unit top to enclosure cap: 4 inches
CERTIFIED FOR CANADA / CERTIFIÉ POUR LE CANADA ANSI Z21-50, CSA 2.22-2016 DO NOT REMOVE THIS LABEL N'ENLEVEZ PAS CETTE ETIQUETTE	
Lab Test 	

Date Issued:	Project No:	Client	Report No:	Revision No:
December 11, 2017	14563	Acucraft Fireplaces	14563-7G	0

Caution and Warnings Label:



CAUTION: Hot while in operation. Do not touch. Severe burns may result. Keep children, clothing, and furniture away.

CAUTION: Keep gasoline and other liquids having flammable vapors away.

Keep burner and control compartment clean.
See installation and operating instructions accompanying appliance.

Warning: Improper installation, adjustment, alteration, service or maintenance can cause injury or property damage. Refer to the owner's information manual provided with this appliance. For assistance or additional information, consult a qualified installer, service agency, or the gas supplier.

This appliance must be installed in accordance with local codes, if any; if none, follow ANSI Z223.1 / NFPA 54, or CSA B149.1

Date Issued:	Project No:	Client	Report No:	Revision No:
December 11, 2017	14563	Acucraft Fireplaces	14563-7G	0

Lighting Instructions:

FOR YOUR SAFETY, READ BEFORE OPERATING

WARNING: If you do not follow these instructions exactly, a fire or explosion may result causing property damage, personal injury, or loss of life.

- A. This appliance has a pilot. It is equipped with an ignition device which automatically lights the burner. Do not try to light the burner by hand.
 - If you cannot reach your gas supplier, call the fire department.
- B. BEFORE OPERATING smell all around the appliance area for gas. Be sure to smell next to the floor because some gas is heavier than air and will settle on the floor.

WHAT TO DO IF YOU SMELL GAS:

 - Do not try to light any appliance
 - Do not touch any electric switch; do not use any phone in your building.
 - Immediately call your gas supplier from a neighbor's phone. Follow the gas supplier's instructions.
- C. Only use your hand to push in or turn the gas control knob. Never use tools. If the knob will not push in or turn by hand, don't try to repair it, call a qualified service technician. Force or attempted repair may result in a fire or explosion.
- D. Do not use this appliance if any part has been under water. Immediately call a qualified service technician to inspect the appliance and to replace any part of the control system and any gas control which has been under water.

OPERATING INSTRUCTIONS

1. STOP! Read the safety information above on this label.
2. Turn off all electric power to the appliance.
3. This appliance is equipped with an ignition system which automatically lights the burner. Do not try to light the burner by hand.

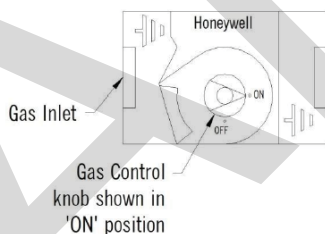

4. Push in gas control knob slightly and turn clockwise to "OFF"

Note: Knob cannot be turned to "OFF" position unless knob is pushed in slightly. Do not force.

5. Wait five (5) minutes to clear out any gas. Then smell for gas, including near the floor. If you smell gas, STOP! Follow "B" in the safety information above on this label. If you don't smell gas, go to the next step.
6. Turn gas control knob counterclockwise to "ON"
7. Replace control access panel.
8. Turn on all electric power to the appliance.
9. If the appliance will not operate, follow the instructions "To Turn Off Gas To Appliance" and call your service technician or gas supplier.

TO TURN OFF GAS TO APPLIANCE

1. Turn off all electric power to the appliance if service is to be performed.
2. Remove control access panel

3. Push in control knob slightly and turn clockwise to "OFF" Do not force
4. Replace control access panel

Date Issued:	Project No:	Client	Report No:	Revision No:
December 11, 2017	14563	Acucraft Fireplaces	14563-7G	0

PRODUCT DESCRIPTION

PRODUCT COVERED

Product Type : Direct Vented Gas Fireplace
 Fuel Type : Natural Gas Only
 Model : Custom Gas L-Shaped Fireplace

PRODUCT DESCRIPTION:

Model Custom Gas L-Shaped Fireplace is an L-shaped direct vented gas fireplace with the glass viewing areas located along the two longest, outside sides and on one of the two ends. Suitable for use with natural gas and for indoor use only. Not for use with solid fuel.

Model Custom Gas L-Shaped Fireplace is suitable for use in high altitude 0 – 4500 feet as per CGA 2.17 M91 Gas Fired Appliances for Use at High Altitudes.

The Custom Gas L-Shaped Fireplace model overall dimensions of approximately 90" wide and 54 ½" high and 78 3/16" in depth. The combustion chamber contains a 56" single-tube linear burner leg and a 70" single-tube linear burner leg that meet at a ninety-degree angle, single brass hex head orifice which is lit by the main pilot flame once the pilot has been proven to allow for main gas flow. Loss of proven pilot results in main gas flow being closed off and trial for re-ignition sequence begins. Burner is constructed of SCH40 black steel with 1/8" holes for main burner gas. Loose burner media consists of reflective ½" thick, ¼" to ½" small chard type fire glass; rated for fireplace media application.

The Custom Gas L-Shaped Fireplace model includes multiple safety shut-off features. The Custom Gas L-Shaped Fireplace model has verified exhaust and venting blockage safety shut-off features, loss of power safety shut-off feature, loss of gas flow safety shut-off features, loss of proven draft shut-off and loss of proven pilot flame sensor.

The Custom Gas L-Shaped Fireplace model pilot lighting safety features include a trial period for proved pilot of 1 minute, followed by a 5-minute lock-out period to vent unburnt gas. The pilot will then attempt to prove for 1 minute and continue the cycle until the pilot proves or the call for heat ends. The system includes a pre-and post-purge period to vent any unburnt gas build-up within the combustion chamber.

The Custom Gas L-Shaped Fireplace model is designed to use a certified UL103 (Class A) chimney pipe. The anchor plate for the flue system is connected to the top of the appliance at the flue outlet. The heat relief venting must utilize a listed B-vent. The two intake runs are for fresh air for combustion air and another for heat relief. The intake and exhaust venting is 8" diameter piping. Exhaust venting must be a minimum of 6 feet in length. All exhaust venting pipes connect at the top of the fireplace and intake piping connects at the bottom of the fireplace.

Date Issued:	Project No:	Client	Report No:	Revision No:
December 11, 2017	14563	Acucraft Fireplaces	14563-7G	0

CLEARANCES TO COMBUSTIBLES

The following are the indoor minimum clearances to combustibles:

Fireplace to back wall of enclosure:	2 inches (50.8 mm)
Fireplace to sidewall of enclosure:	2 inches (50.8 mm)
Fireplace to top of enclosure:	4 inches (101.6 mm)

COMPONENTS:

- Automatic Gas Ignition System with Gas Valve:** cCSAus certified (file number 112702), Manufactured by Dexen Industries, Inc., model # GM 8K-935, with GM935 gas valve. Temperature ratings of -23°C to 79.4°C. Rated 6 VDC, 1.5 A input voltage; operating current 0.8 A. Limited adjustment gas pressure, range 1.5 to 4.0" water column for natural gas/ 4.5 to 10" water column for propane. Maximum capacity of 150,000 BTU/hr.
- Intermittent Pilot Gas Ignition Control (alternate natural gas option only):** CSA certified (file number 112491_0_000), Manufactured by Honeywell International, Inc., model # S8610U. Temperature ratings of -40°C to 74°C. Rated 24 Vac 50/60 Hz.
- Dual Valve Combination Gas Control (alternate natural gas option only):** CSA certified (file number 112395_0_000), Manufactured by Honeywell International, Inc., model # VR8204A. Temperature ratings of -18°C to 79°C. 150 cubic feet per hour capacity. Pipe size of 1/2" x 1/2" NPT.
- Pilot Burner Assembly:** cCSAus certified (file number 112395), Manufactured by Honeywell International, Inc., model # Q314A. Non-aerated. Insert orifice type. Equipped with Honeywell ignition cable, part number 392125-2; and with Baso pilot stainless steel tubing, part number M-IC-Y99AR-1H.
- Automatic Draft Control:** cETLus listed (file number 3163711). Manufactured by Energex, model # ADC100. Temperature ratings of -20°C to 50°C. Rated 120 Vac, 6.3 A.
- Proven Draft Switch:** cETLus listed (file number 316111). Manufactured by Energex, model # PDS1. Temperature ratings of -40°C to 88°C. Maximum pressure of 3 PSI. Rated 120 Vac, 3 A.
- Chimney Fan:** cETLus listed (file number 4001217). Manufactured by Exhausto, Inc., model # RS-14. Maximum operating temperature of 300°C. Rated 120 Vac, 60 Hz, 1.4 A, 100 W. Maximum cubic feet per minute of 1400.
- Heat Relief Fan:** cULus listed (file number E47996). Manufactured by KB Electronics, model # K8XL. Maximum operating temperature of 60°C. Rated 120 Vac, 60 Hz, 1.32 A, 150 W.
- Draft Control Switch:** UL recognized (file number MH29434). Manufactured by Endura Plastics, model # ES2151-0460. Rated to 0.05" WC pressure.
- Power Supply Switching Adapter:** cULus listed (file number E164369). Manufactured by Sino-American, model # SA110L-05S. Rated input 100-240 Vac, 50/60 Hz, 0.3 A; rated output 6 V, 1.5 A, 9 W.
- Relay:** cULus listed (file number E40944). Manufactured by Dayton Electric Manufacturing Company, model # 1A4870. Rated 24VDC coil.
- Electrical Transformer:** UL listed (listing number E197146). Manufactured by Functional Devices, Inc., model # TR75VA002, tradename RIB. Class 2 transformer. Primary input voltage rated (60 Hz) 120/208/240. Output rated 75 VA.

Date Issued:	Project No:	Client	Report No:	Revision No:
December 11, 2017	14563	Acucraft Fireplaces	14563-7G	0

13. Venting: Certified to UL 103HT by Intertek Testing Services (listing # 50195-C7-704800). Type "A" factory-built chimney suitable for venting negative or neutral draft (non-pressurized) appliances including fireplaces. Constructed of type 304 stainless steel and inclusive of high temperature mineral fiber. Maximum rated flue gas temperatures of 1000°F continuous and 2100°F at ten minutes.

14. Glass Front and Back: Tempered glass; impact and thermal shock tested. Dual pane, rectangular shape with dimensions of 72" wide by 24" high and 1/4" thick. Tested with the appliance.

SAMPLE

Date Issued:	Project No:	Client	Report No:	Revision No:
December 11, 2017	14563	Acucraft Fireplaces	14563-7G	0

FIGURES / DIAGRAMS

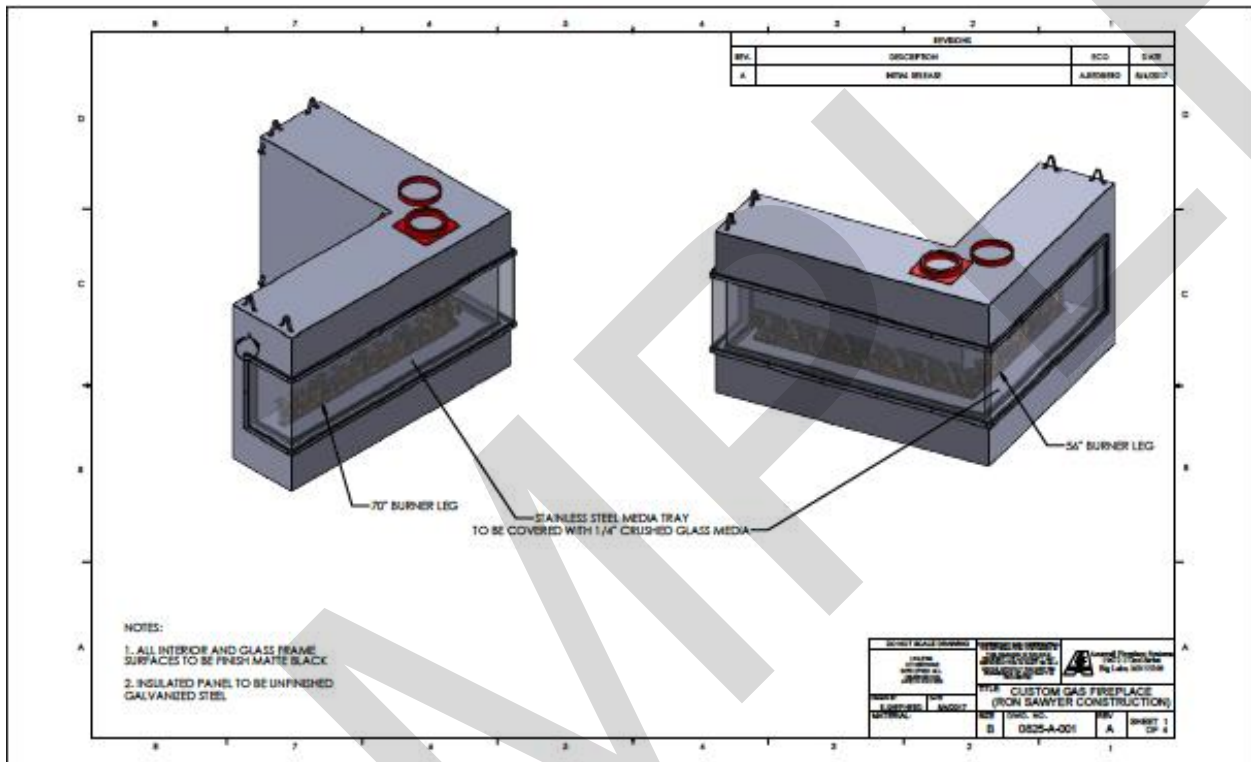

Figure 1 – Custom Gas L-Shaped Fireplace Design Drawing

Date Issued:	Project No:	Client	Report No:	Revision No:
December 11, 2017	14563	Acucraft Fireplaces	14563-7G	0

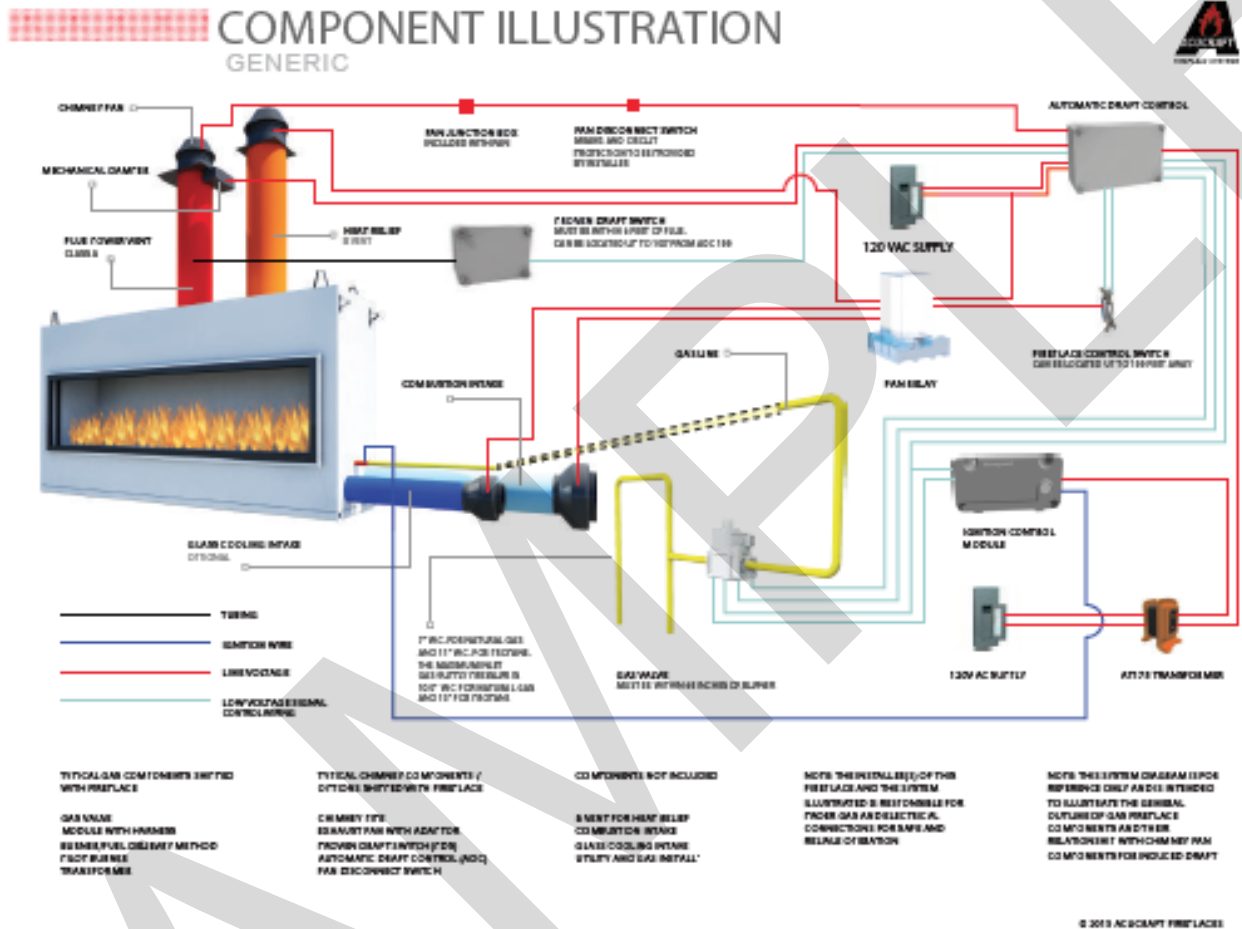

Figure 2 – Custom Gas L-Shaped Fireplace Component Illustration Example

Date Issued:	Project No:	Client	Report No:	Revision No:
December 11, 2017	14563	Acucraft Fireplaces	14563-7G	0

SPECIFICATIONS		
Height = 54 1/2" Width = 90" Depth = 78 3/16" Appx Weight. = 2500lbs Gas Type = Natural Gas Flue Size = 10" Flue Type = 103HT Electrical = Single 15AMP service	NATURAL GAS Input Rating (BTU/hr) 0-1370 m = 200,000 BTUs/hr. Minimum inlet pressure (in.w.c.) = 7.0 in. W.C. Maximum inlet pressure (in.w.c.) = 10.5 in. W.C. Combustion Air inlet size= Dual 8" Ducts Glass Cooling Air inlet size = Dual 8" Ducts	Based on testing that was performed, the following results have been recorded. Minimum Clearances to combustibles Unit to back wall of enclosure = 2 inches Unit to sidewall of enclosure = 2 inches Unit top to enclosure top = 4 inches NOTE: A 12" B-Vent used as a duct to remove heat from the top to the outdoors must be installed to maintain these clearances. (SUPPLIED BY OTHER)
Note: The chimney flue for the appliance should never be connected to another chimney flue in any way.		

Figure 3 – Custom Gas L-Shaped Fireplace Product Specifications

Date Issued:	Project No:	Client	Report No:	Revision No:
December 11, 2017	14563	Acucraft Fireplaces	14563-7G	0

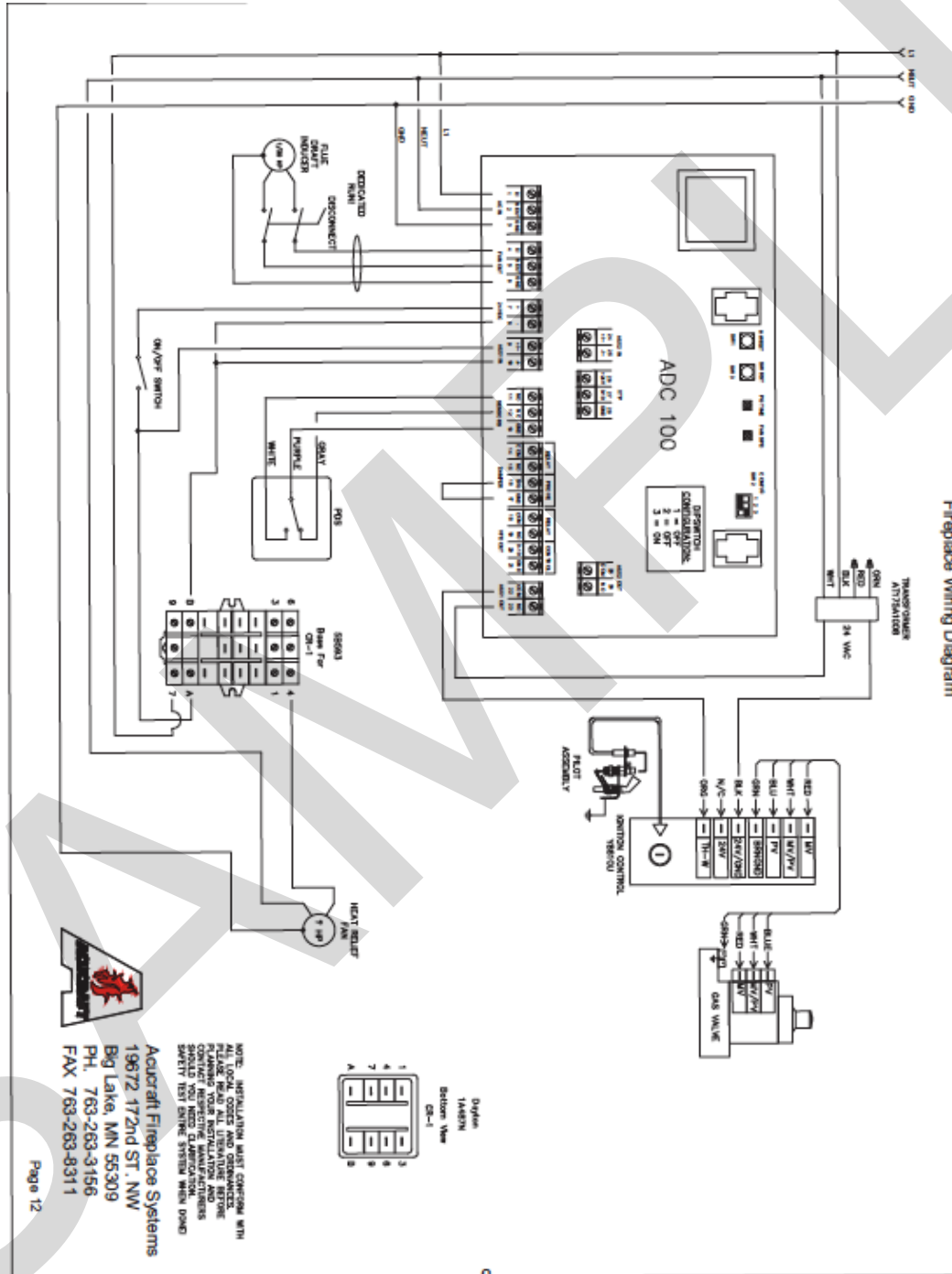

Figure 4 – Custom Gas L-Shaped Fireplace Wiring Diagram

Date Issued:	Project No:	Client	Report No:	Revision No:
December 11, 2017	14563	Acucraft Fireplaces	14563-7G	0

PICTURES



Picture 1 – Custom Gas L-Shaped Fireplace Front View

LISTING REPORT

Date Issued:	Project No:	Client	Report No:	Revision No:
December 11, 2017	14563	Acucraft Fireplaces	14563-7G	0



Picture 2 – Custom Gas L-Shaped Fireplace Front and Side View

Date Issued:	Project No:	Client	Report No:	Revision No:
December 11, 2017	14563	Acucraft Fireplaces	14563-7G	0



Picture 3 – Custom Gas L-Shaped Fireplace View of Dual Pane Glass with Glass Cooling Space

Date Issued:	Project No:	Client	Report No:	Revision No:
December 11, 2017	14563	Acucraft Fireplaces	14563-7G	0



Picture 4 – Custom Gas L-Shaped Fireplace Flue Vent Pipe with Chimney Fan Component

Date Issued:	Project No:	Client	Report No:	Revision No:
December 11, 2017	14563	Acucraft Fireplaces	14563-7G	0



Picture 5 – Custom Gas L-Shaped Fireplace Glass Cooling Air Intake and Combustion Air Intake

Date Issued:	Project No:	Client	Report No:	Revision No:
December 11, 2017	14563	Acucraft Fireplaces	14563-7G	0



Picture 6 – Custom Gas L-Shaped Fireplace Proven Draft Switch Component

Date Issued:	Project No:	Client	Report No:	Revision No:
December 11, 2017	14563	Acucraft Fireplaces	14563-7G	0



Picture 7 – Custom Gas L-Shaped Fireplace Automatic Gas Valve Component

Date Issued:	Project No:	Client	Report No:	Revision No:
December 11, 2017	14563	Acucraft Fireplaces	14563-7G	0

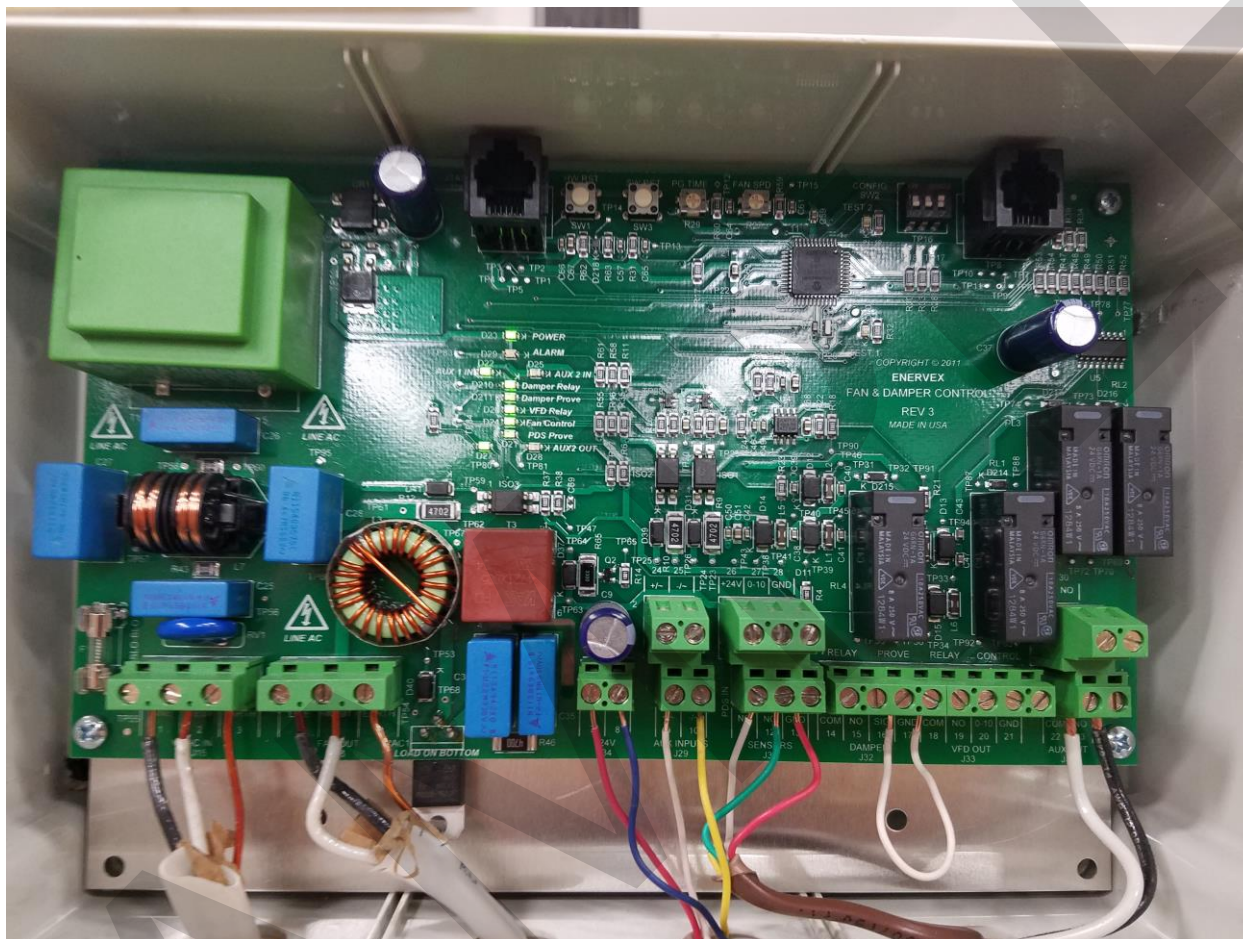

Picture 8 – Custom Gas L-Shaped Fireplace Draft Control Component

LISTING REPORT

Date Issued:	Project No:	Client	Report No:	Revision No:
December 11, 2017	14563	Acucraft Fireplaces	14563-7G	0



Picture 9 – Custom Gas L-Shaped Fireplace Transformer Component

LISTING REPORT

Date Issued:	Project No:	Client	Report No:	Revision No:
December 11, 2017	14563	Acucraft Fireplaces	14563-7G	0



Picture 10 – Custom Gas L-Shaped Fireplace Pilot Ignition Module Component

Date Issued:	Project No:	Client	Report No:	Revision No:
December 11, 2017	14563	Acucraft Fireplaces	14563-7G	0



Picture 11 – Custom Gas L-Shaped Fireplace Automatic Gas Valve Component

Date Issued:	Project No:	Client	Report No:	Revision No:
December 11, 2017	14563	Acucraft Fireplaces	14563-7G	0

INSTALLATION AND OPERATING MANUAL



Acucraft Custom Gas L-Shaped Fireplace

Serial #: 0825

This is a vented decorative gas appliance: not a source of heat; not for use with solid fuel.

WARNING:
FIRE OR EXPLOSION HAZARD
Failure to follow safety warnings exactly could result in serious injury, death, or property damage.

- Do not store or use gasoline or other flammable vapors and liquids in the vicinity of this or any other appliance.

- WHAT TO DO IF YOU SMELL GAS

- Do not try to light any appliance.
- Do not touch any electrical switch; do not use any phone in your building.
- Leave the building immediately.
- Immediately call your gas supplier from a neighbor's phone. Follow the gas supplier's instructions.
- If you cannot reach your gas supplier, call the fire department.

- Installation and service must be performed by a qualified installer, service agency or the gas supplier.

INSTALLER: Leave this manual with the appliance.
CONSUMER: Retain this manual for future reference



www.acucraft.com 888-317-6499

Installation/Operator's Manual

Rev2

Date Issued:	Project No:	Client	Report No:	Revision No:
December 11, 2017	14563	Acucraft Fireplaces	14563-7G	0

TABLE OF CONTENTS

Introduction	pg 3
Safety / Warnings	pg 4-6
Installation Guide	
System Illustration	pg 7
Wiring Diagrams	pg 8
Positioning the Fireplace	pg 9
Installing the Ventilation System	pg 10-12
Connecting the Gas Valve & Ignition System	pg 13
Installing the Glass Panel	pg 14
 Blaze 6 Components	
Component Quick Reference Guide & Replacement Parts...	pg 15
Draft Controller	pg 16-18
Gas Valve & Ignition Module	pg 19-23
Draft Switch	pg 24-25
Inline Fan	pg 26
Chimney Fan	pg 27-32
Notes	pg 33
 Operation Guide	
Specifications	pg 34-36
Operation Guide	pg 37-38
Troubleshooting	pg 39
Maintenance & Care	pg 40
Notes	pg 41
 Warranty	 pg 42

Date Issued:	Project No:	Client	Report No:	Revision No:
December 11, 2017	14563	Acucraft Fireplaces	14563-7G	0

INTRODUCTION

Dedication to innovation, honesty, excellence, and hard work ensure that we can provide solutions to each and every one of our customers.

Our team stays up-to-date on all the latest trends and technologies to ensure we can provide customers with the perfect solution for their project. Our passion for excellence paves the way for our world-class products, systems & customer service. Our goal is to revolutionize the fireplace industry not by being the biggest, but by being the best. We push ourselves to do more than we think we are capable of. We are a family first organization, and we strive to be good stewards locally, nationally, and internationally.

Please review this manual carefully before installing your new fireplace.

Acucraft Custom Gas L-Shaped Fireplace
Serial #: 0825



Acucraft Fireplaces
19672 172nd Street
Big Lake, MN 55309

www.acucraft.com 888-317-6499

Date Issued:	Project No:	Client	Report No:	Revision No:
December 11, 2017	14563	Acucraft Fireplaces	14563-7G	0

SAFETY

INSTALLATION GUIDELINES:

- Acucraft does not install fireplace systems.
- Contact a licensed installer for proper installation.

Installation and repair should be done by a qualified service person. The appliance should be inspected before use and at least annually by a professional service person. More frequent cleaning may be required due to excessive lint from carpeting, bedding material, etc. It is imperative that control compartments, burners, and circulating air passageways of the appliance be kept clean.

Instructions are included for removal and re-installation of the glass panels. Only tempered glass is certified for use with this appliance. This fireplace is NOT certified to be used without a glass front and sides. DO NOT use if any portion or pane of glass is broken, cracked, damaged, or otherwise visually flawed. Contact a technician to replace the damaged panel immediately.

Do not use this appliance if any part has been under water. Immediately call a qualified service technician to inspect the appliance and to replace any part of the control system and any gas control which has been under water.

This appliance is not for use with glass doors.

INSTALLATION SAFETY CODES:

These instructions should be used as a guideline only, and do not supersede local codes in any way. Please check with local codes before installation.

In the absence of local codes, use the current National Fuel Gas Code – ANSI Z223.1 (NFPA 54) or CAN/CGA B149 Installation Code.

The appliance, when installed, must be electrically grounded in accordance with local codes or, in the absence of local codes, with the National Electrical Code, ANSI/NFPA 70, or the Canadian Electrical Code, Part 1 CSA C22.1.

Installed venting must conform to local codes or, in the absence of local codes, to National Fuel Gas Code (ANSI-Z223.1) or to CAN/CSA-B149.1

SAFETY STATEMENTS:

Safety is very important and is referenced throughout this manual in different ways. There are two different safety levels that you should be aware of. Warning statements will occur when there is a possibility of bodily harm present. Caution statements will occur when there presents a risk of damage to the unit if the statements are not followed correctly. Below are examples of what the statements look like.



WARNING

This statement is used when personal injury may result if not followed properly.







CAUTION

This statement is used when equipment damage may result if not followed properly.

LISTING REPORT

Date Issued:	Project No:	Client	Report No:	Revision No:
December 11, 2017	14563	Acucraft Fireplaces	14563-7G	0

SAFETY

 WARNING	
	<p style="text-align: center;">FIRE & EXPLOSION HAZARD</p> <p>Gasoline or flammable vapors can ignite or explode. Do not store or use gasoline or other flammable vapors and liquids in the vicinity of this or any other appliance. Follow lighting instructions provided on the label of the fireplace and in this manual. If the information in these instructions are not followed exactly, a fire or explosion may result causing property damage, personal injury or loss of life.</p>
	<p style="text-align: center;">VENTILATION</p> <p>Make sure the appliance has proper ventilation as instructed in this manual. Gas vapors can cause personal injury or loss of life.</p> <p>What to do if you smell gas:</p> <ul style="list-style-type: none"> • Do not try to light any appliance • No not touch any electrical switch • Immediately call gas supplier from a neighbor's phone. Do not use any phone in the building. • Follow the gas supplier's instructions • If you can not reach your gas supplier, call the fire department.
	<p style="text-align: center;">HOT SURFACE HAZARD</p> <p>The glass on the fireplace will become hot while in use. Hot glass will cause burns. Keep children away from hot surface to avoid burns or clothing ignition. Never touch glass until cooled. If burns occur, seek immediate medical attention.</p>

Date Issued:	Project No:	Client	Report No:	Revision No:
December 11, 2017	14563	Acucraft Fireplaces	14563-7G	0

SAFETY

Due to high temperatures, the appliance should be located out of traffic and away from furniture and draperies.

Clothing or other flammable material should not be placed on or near the appliance.

Children and adults should be alerted to the hazards of high surface temperature and should stay away to avoid burns or clothing ignition.

Young children should be carefully supervised when they are in the same room as the appliance. Toddlers, young children and others may be susceptible to accidental contact burns. A physical barrier is recommended if there are at-risk individuals in the house. To restrict access to a fireplace or stove, install an adjustable safety gate to keep toddlers, young children and other at-risk individuals out of the room and away from hot surfaces.

Any safety screen or guard removed for servicing an appliance, including glass panels, must be replaced prior to operating the appliance.

Date Issued:	Project No:	Client	Report No:	Revision No:
December 11, 2017	14563	Acucraft Fireplaces	14563-7G	0

INSTALLATION GUIDE

This is a vented decorative gas appliance: not a source of heat; not for use with solid fuel.

IMPORTANT NOTE TO INSTALLER:

1. This appliance is not intended or designed to be installed in a mobile or manufactured home.
2. If this appliance is installed on carpeting, tile, or any combustible material other than wood flooring, the appliance shall be installed on a metal, concrete, or wood panel extending the full width and depth of the fireplace.
3. The appliance and its main gas valve must be disconnected from the gas supply piping system during any pressure testing of that system at test pressures in excess of ½ psi. (3.5 k/Pa) The appliance must be isolated from the gas valve supply piping system by closing the equipment shutoff valve during any pressure testing of the gas supply piping system at test pressures equal to or less than ½ psi (3.5 k/Pa)

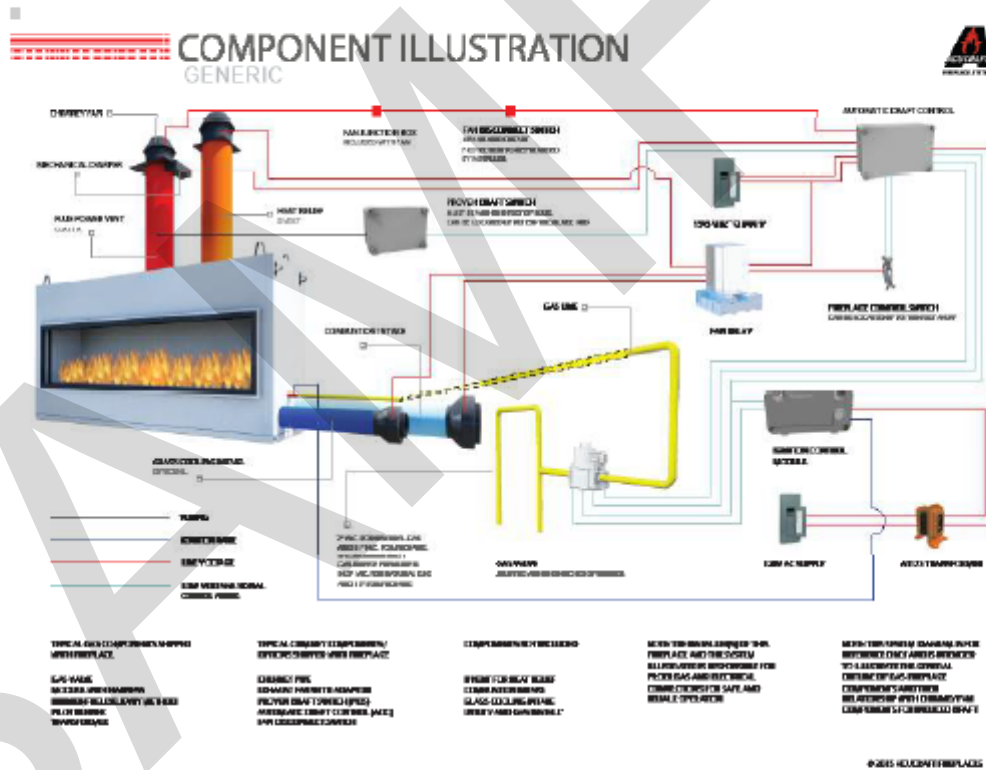

Date Issued:	Project No:	Client	Report No:	Revision No:
December 11, 2017	14563	Acucraft Fireplaces	14563-7G	0

INSTALLATION GUIDE

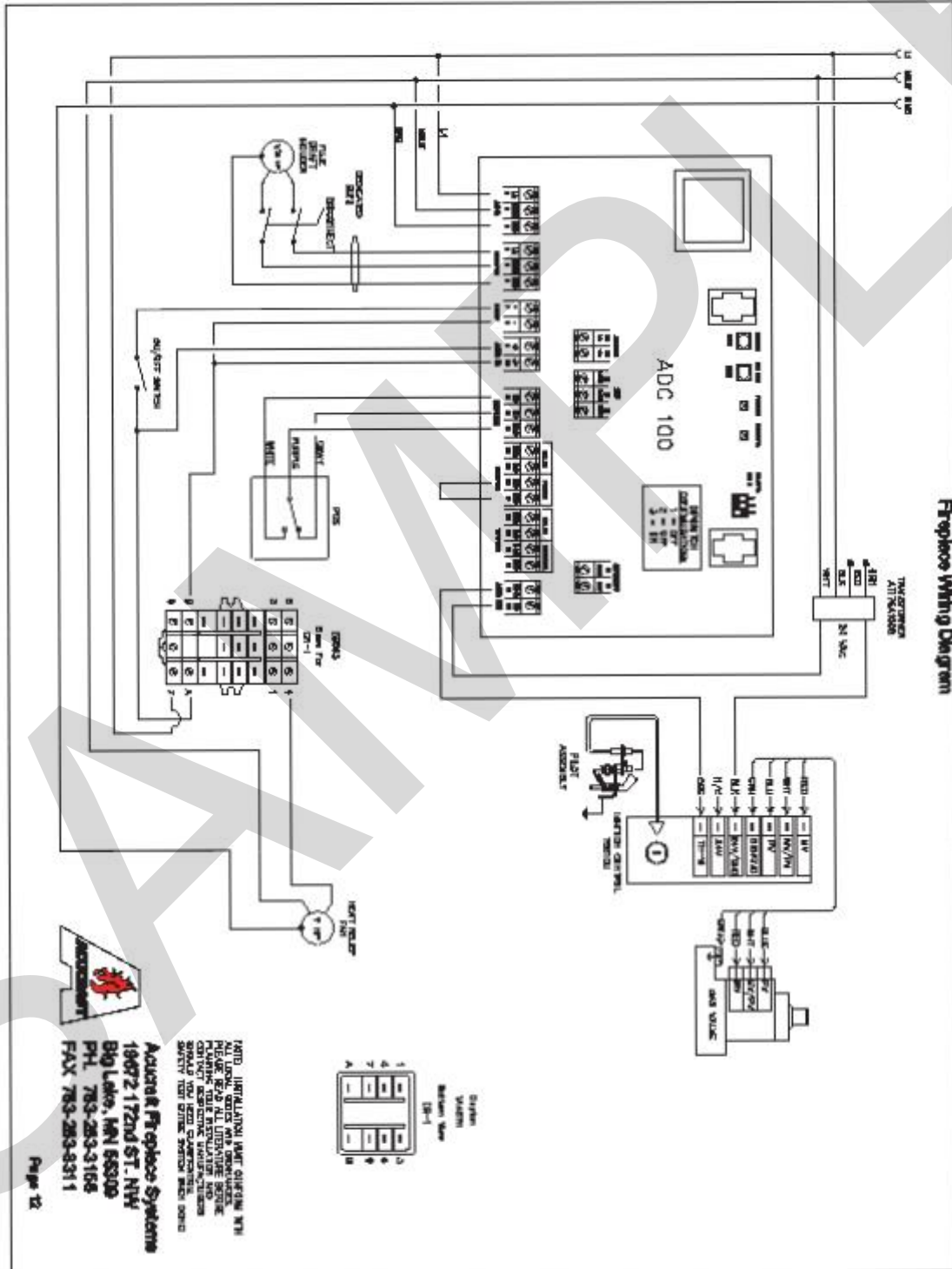

Date Issued:	Project No:	Client	Report No:	Revision No:
December 11, 2017	14563	Acucraft Fireplaces	14563-7G	0

INSTALLATION GUIDE

Positioning the Fireplace

Using a hand truck or other appropriate equipment, that is rated to handle the weight of the fireplace safely move the fireplace into position. (estimated weight 1500 lbs)



Clearance to combustibles:

- Top of appliance = 4"
- Sides of appliance = 2"
- Back of appliance = 2"
- Bottom of appliance = 0"

Vent clearance to combustibles:

- Class A exhaust flue = 2"
- B-vent heat relief venting = 1"

IMPORTANT: Clearances must be in accordance with local installation codes and the requirements of the gas supplier.

Les dégagements sont conformes aux codes d'installation locaux et aux exigences du fournisseur de gaz.

Determine the location of the appliance to ensure that the combustion air supply and the flue gas/chimney pipe connections are to be made as designed. The appliance is designed to sit either directly on the floor or to sit on a base designed to support the weight of the appliance for proper elevation. If shimming is required to level the appliance due to uneven surfaces, shimming the perimeter of the base is the preferred method. Anchor the appliance adequately to prevent future movement.

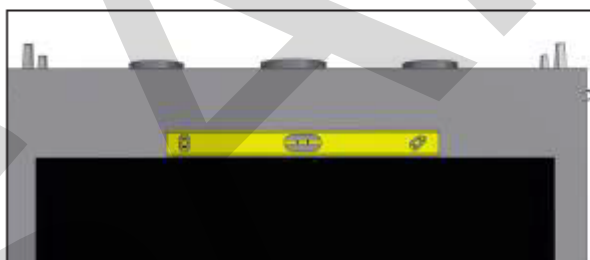
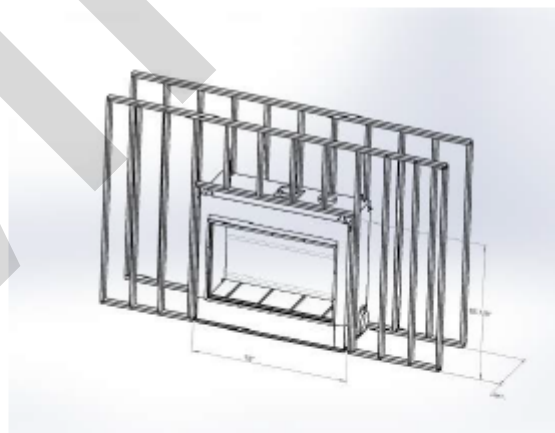

Note: The appliance should be positioned in a manner that planned electrical and gas line access is available with adequate clearance for servicing.

Date Issued:	Project No:	Client	Report No:	Revision No:
December 11, 2017	14563	Acucraft Fireplaces	14563-7G	0

INSTALLATION GUIDE

Vent terminal locations to intersecting walls, overhangs or eaves, window openings, air intakes, above-ground grade or deck shall maintain the clearances specified as shown below.
Vent terminals shall not be recessed into a wall or siding.

Installing the Ventilation

The entire ventilation system, including Class A exhaust flue, fresh air intakes, and B-Vent heat relief venting are predetermined on this appliance.

The venting configuration may or may not include any or all of the following components, depending on design: auto draft control model ADC-100, proven draft switch model PDS-1, or ventilation fans.

Exhaust Flue: When installing the UL103HT (Class A) chimney pipe from the fireplace, it must be attached securely to the provided anchor plate. Please consult and follow the manufacturer's instructions included with the chimney pipe and supplied with this manual. If a damper is to be installed in the flue, it must be at a location that meets the manufacturer's specifications, and that is serving only the appliance exhaust.

CAUTION: Extreme temperatures if damper is not used!

Combustion air supply: It is always recommended to minimize any turns or elbows in these supply lines that would cause restriction.

Heat relief venting: Requires connecting a single B-Vent flue to a starter collar located and marked on top of the appliance, running from the top of the appliance.

Vent Terminal Locations

Vents terminating above roofs, whether flat or pitched, must be a minimum of 12" higher than the termination, as shown below.

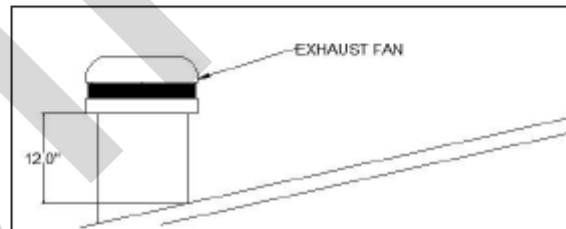

Below drawing: dimensions are located on subsequent page (p.12).

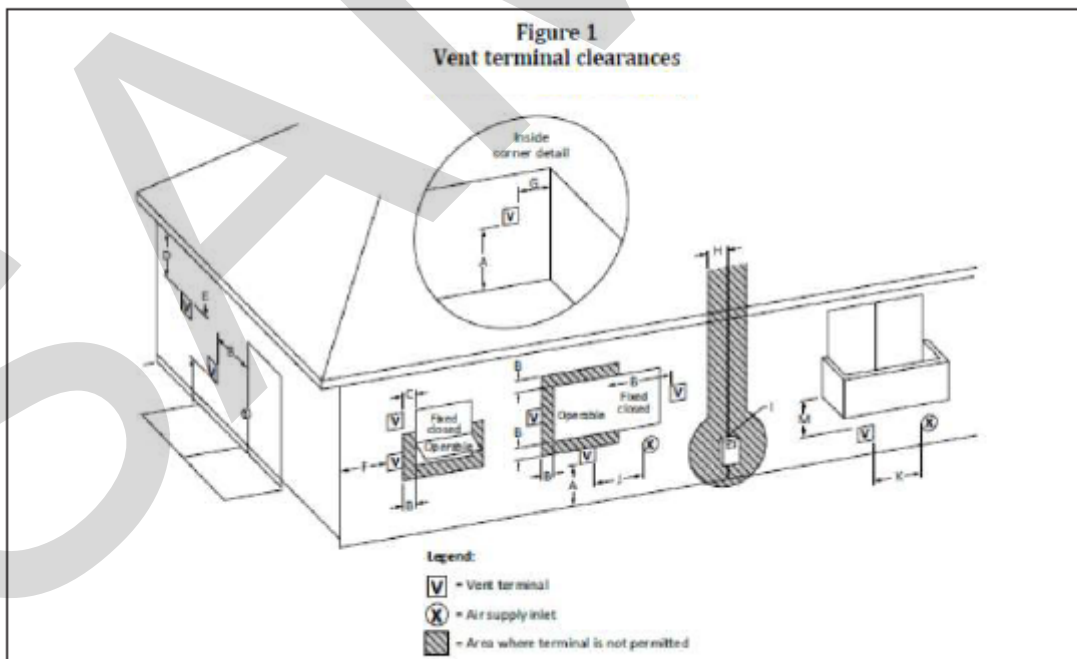

Date Issued:	Project No:	Client	Report No:	Revision No:
December 11, 2017	14563	Acucraft Fireplaces	14563-7G	0

INSTALLATION GUIDE

		US installations ²
A	Clearance above grade, veranda, porch, desk or balcony	12in (30 cm)
B	Clearance to window or door that may be opened	6 in (15 cm) for appliances ≤ 10,000 Btuh (3 kW), 9 in (23 cm) for appliances > 10,000 Btuh (3 kW) and ≤ 50,000 Bruh (15 kW), 12 in (30 cm) for appliances > 50,000 Btuh (15 kW)
C	Clearance to permanently closed window	*
D	Vertical clearance to ventilated soffit located above the terminal within a horizontal distance of 2 feet (61 cm) from the center line of the terminal	*
E	Clearance to unventilated soffit	*
F	Clearance to outside corner	*
G	Clearance to inside corner	*
H	Clearance to each side of center line extended above meter / regulator assembly	*
I	Clearance to service regulator vent outlet	*
J	Clearance to nonmechanical air supply inlet to building or the combustion air inlet to any other appliance	6 in (15 cm) for appliances ≤ 10,000 Btuh (3 kW), 9 in (23 cm) for appliances > 10,000 Btuh (3 kW) and ≤ 50,000 Bruh (15 kW), 12 in (30 cm) for appliances > 50,000 Btuh (15 kW)
K	Clearance to a mechanical air supply inlet	3 ft (91 cm) above if within 10 ft (3 m) horizontally
L	Clearance above paved sidewalk or paved driveway located on public property	*
M	Clearance under veranda, porch deck, or balcony	*

Notes:

1) In accordance with the current CSA B149.1, Natural Gas and Propane Installation Code.

2) In accordance with the current ANSI Z223.1/NFPA 54, National Fuel Gas Code.

*For clearances not specified in ANSI Z223.1/NFPA 54 or CSDA B149.1, one of the following shall be indicated:

a) A minimum clearance value determined by testing in accordance with Clause 5.25.5, or;

b) A reference to the following footnote:

"Clearance in accordance with local installation codes and requirements of the gas supplier."

† A vent shall not terminate directly above a sidewalk or paved driveway that is located between two single family dwellings and serves both dwellings.

‡ Permitted only if veranda, porch, deck, or balcony is fully open on a minimum of two sides beneath the floor.

LISTING REPORT

Date Issued:	Project No:	Client	Report No:	Revision No:
December 11, 2017	14563	Acucraft Fireplaces	14563-7G	0

SUPPLEMENTAL MATERIAL

VENT REQUIREMENTS

Vent Requirements

- The gas appliance and vent system must be vented directly to the outside of the building, and never be attached to a chimney serving a separate solid fuel or gas-burning appliance. Each direct vent gas appliance must use its own separate vent system.
- In addition to the requirements listed here, follow the requirements provided with the vent.

Vent Installation

- Slide the vent sections together, use screws provided with flue (3 screws at each joint).
- No silicone is required
- Wall supports are required at a minimum of every 8 feet.

Vent Clearances

- The vent must maintain the required clearance to combustible materials to prevent a fire. Do not fill air spaces with insulation.
- Minimum Vent Configurations (elbow directly off fireplace):
- Clearances are in accordance with local installation codes and requirements of the gas supplier.
- Les dégagements sont conformes aux codes d'installation locaux et aux exigences du fournisseur de gaz.

Minimum Clearance Above Vent	2"
Minimum Clearance to Sides & Below Vent	2"

Vent Firestop

- A firestop is required whenever the vent penetrates a wall, floor, or ceiling (passes through framing members)

Approved Vent

- Installation instructions for ICC Excel Factory Built Chimney may be found at: www.icc-rsf.com

Date Issued:	Project No:	Client	Report No:	Revision No:
December 11, 2017	14563	Acucraft Fireplaces	14563-7G	0

INSTALLATION GUIDE

Connecting the Gas Valve & Ignition System

IMPORTANT:

All connections and components should be made and installed by qualified persons only and checked and tested for leaks prior to wiring of valve module.

Gas supply should be connected as shown below.

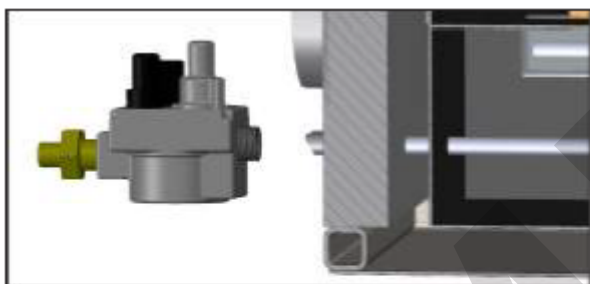

The location of the stubbed gas line port and electrical pass through port for running the ignition cable are determined during design. The location may either be directly with the fireplace, or these components may be remotely located nearby, but never in a location to exceed 5' length of ignition cable from the burner itself.

Please refer to the specific component installation manuals for the electronic gas valve, intermittent pilot module, pilot assembly, and transformer supplied with this fireplace and written by the manufacturer.

- Connect the ignition cable and other wiring to the valve and direct intermittent pilot module as shown below.

NOTE: These illustrations are not to scale and are for reference only. For more detailed schematics, refer to appropriate components in back of this manual.

Directions for Connecting a Gas Pressure Test Gauge

The gas control valve (shown to the right) has two test ports for testing input (line pressure) and output (manifold) pressure. Loosen the brass screw on either test port and place a 5/16" i.d. rubber or plastic tube over the tapered test port. Connect the tube to the test gauge.

WARNING: The brass screw must be tightened after testing to prevent gas leakage.

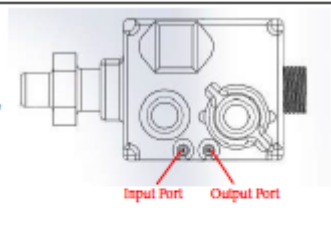

Date Issued:	Project No:	Client	Report No:	Revision No:
December 11, 2017	14563	Acucraft Fireplaces	14563-7G	0

INSTALLATION GUIDE

Installing the Dual Pane Glass

	 WARNING Always wear protective equipment when dealing with hot surfaces. Failure to follow this warning may result in serious injury.
---	---

Step 1: Install inner pane of glass in the channel



Step 2: Install the inner frame with the countersunk screws provided



Step 3: Install the outer glass in the channel



Step 4: Install the outer removable frame with the countersunk screws provided



Date Issued:	Project No:	Client	Report No:	Revision No:
December 11, 2017	14563	Acucraft Fireplaces	14563-7G	0

REPLACEMENT COMPONENTS INFORMATION

IMPORTANT:

This fireplace system consists of several components that are designed specifically for this appliance. No parts on this appliance may be substituted or replaced with anything other than original components. Replacement parts as listed below can be obtained by contacting Acucraft Customer Service by phone or email.

Acucraft Customer Service Contact Information:

- Phone: (763) 263-3156
- Email: info@acucraft.com

COMPONENT DESCRIPTION	INSTALL INFORMATION PAGE(s)
Flue / Venting	10-12
Glass Panels	14
Draft Controller	16-18
Gas Valve & Ignition Module	19-23
Draft Switch	24-25
Inline Fan	26
Chimney Fan	27-32

WARNING:

Failure to position the parts in accordance with these diagrams or failure to use only parts specifically approved with this appliance may result in property damage or personal injury.

LISTING REPORT

Date Issued:	Project No:	Client	Report No:	Revision No:
December 11, 2017	14563	Acucraft Fireplaces	14563-7G	0

SUPPLEMENTAL MATERIAL

Draft Controller

Product Information

USE:

The Control Board is a fan speed and appliance control used to control draft for a gas appliance such as a fireplace, stove or furnace. It may be interlocked with the appliance and is for use in systems where modulation is not required. It controls the speed of a fan to maintain proper draft and pressure in a chimney system. The Control Board is for use with chimney fans.

FUNCTION:

The Control Board comes with the Draft Switch. The Draft Switch is a required safety function used to ensure a negative pressure is maintained in the chimney. It also prevents appliance operation during an electrical or mechanical failure in the system. The Control Board can operate the chimney fan in manual or automatic mode. Manual mode allows the user to adjust the speed of the fan at any time using the potentiometer on the board. In Automatic Mode, the Control Board will ignore the potentiometer and ramp the fan up until the Draft Switch closes. If the Draft Switch opens, the control will ramp up the fan until there is enough draft to re-close the switch.

CONSTRUCTION:

The housing is NEMA 1 rated ABS plastic.

CODE COMPLIANCE:

System installation must conform to the requirements of the authority having jurisdiction. When required by the authority having jurisdiction, the installation must also conform to the NFPA31, NFPA54 or NFPA211. All electrical wiring must be in accordance with the requirements of the authority having jurisdiction or, in absence of such requirements, with the National Electric Code, NFPA 70.

Shipping Information

The Control Board includes the control unit, Draft Switch, stack probe and silicone tubing.

* If other components are shipped, they will appear as separate items on the packing list.

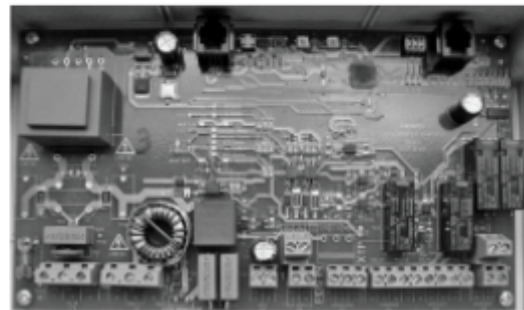

Date Issued:	Project No:	Client	Report No:	Revision No:
December 11, 2017	14563	Acucraft Fireplaces	14563-7G	0

SUPPLEMENTAL MATERIAL

Draft Controller

Specifications

Dimensions & Capacities:	
Power Supply = V	1x120 VAC
Amperage = A	6.3
Operating Temp = °F/°C	-4 to 122 / -20 to 50
Control Signal = mA	max. 10
Control relay	max. 120 VAC / 8A
Output	VAC = 10-120 VDC = 0-10
Post Purge Time	0-3 Minutes
Alarm Delay Time	15 Seconds
Dimensions (see below)	
Weight = lbs/kg	2.8 / 1.2

Dimensions		
Control Board	A	9.6 in / 244 mm
	B	6.3 in / 160 mm
	C	3.5 in / 90 mm
Chimney Probe	D	4.25 in / 108 mm
	E	3.50 in / 89 mm

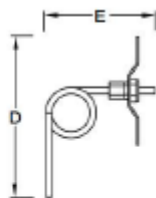
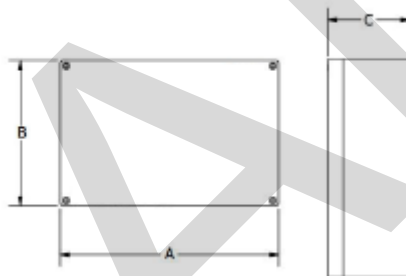

Mechanical Installation

LOCATION:

The Control Board must be installed indoors. As shown in the diagram below, the control will be wired directly to a 120/1/60 VAC power supply. The control will also be connected to the fan, appliance and damper (if used). For detailed wiring information, see Electrical Installation.

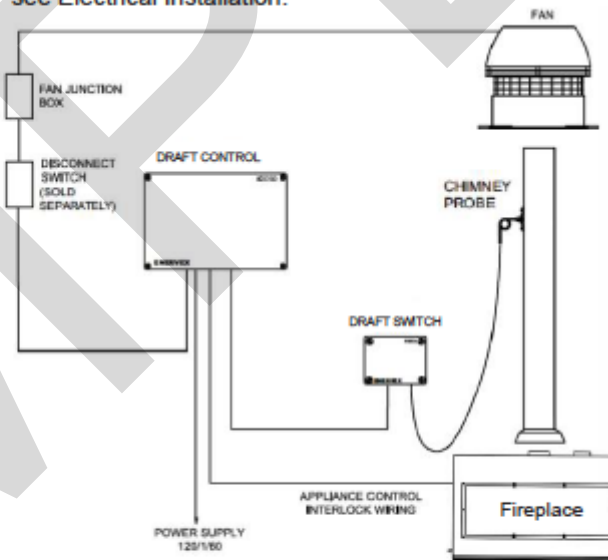

MOUNTING THE CONTROL UNIT:

The Control Board may be mounted directly to a wall. To mount, remove the cover and locate the (4) mounting holes. Using the hole-pattern shown below, mount the control using #6 screws. Once it is attached, wire the unit in accordance with Electrical Installation section of this manual.

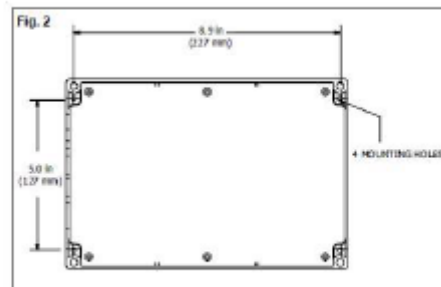

Date Issued:	Project No:	Client	Report No:	Revision No:
December 11, 2017	14563	Acucraft Fireplaces	14563-7G	0

SUPPLEMENTAL MATERIAL

Draft Controller

CONNECTION OF THE DRAFT SWITCH AND STACK PROBE:

The Draft Switch must be installed indoors, in the vertical position (pre-drilled knockouts face down). Mount the control upright to a wall or other flat surface. Do NOT lay the control down or mount horizontally.

A Draft Switch must be used with the Control Board as a system safety device. The Draft Switch monitors the pressure inside the stack and signals the control to shut down the appliance if insufficient draft exists. A stack probe senses the pressure read by the Draft Switch and is connected via silicone tubing.

The silicone tubing supplied with the Draft Switch should be connected to the NEGATIVE (-) port of the Draft Switch. This is the bottom port on the switch. The standard tube length is 6 feet. The distance can be extended up to 25 feet by using 1/4" rigid plastic or copper tubing as temperature allows (not supplied).

The image below is for reference only; the draft switch must be installed in a vertical position.

INSTALLATION OF THE CHIMNEY PROBE:

The probe must be installed between the appliance and the exhaust fan. If a damper is used in the system, the probe should be installed between the appliance and damper.

Locate the probe at least a distance three (3) vent diameters away from any elbow, tee or damper. For fireplace installations, the probe should be installed close to the fan inlet as shown below.

To produce an accurate pressure reading, the probe should be installed flush with the inner wall of the chimney or stack. If double walled stack is used, the probe should be flush with the inner most wall.

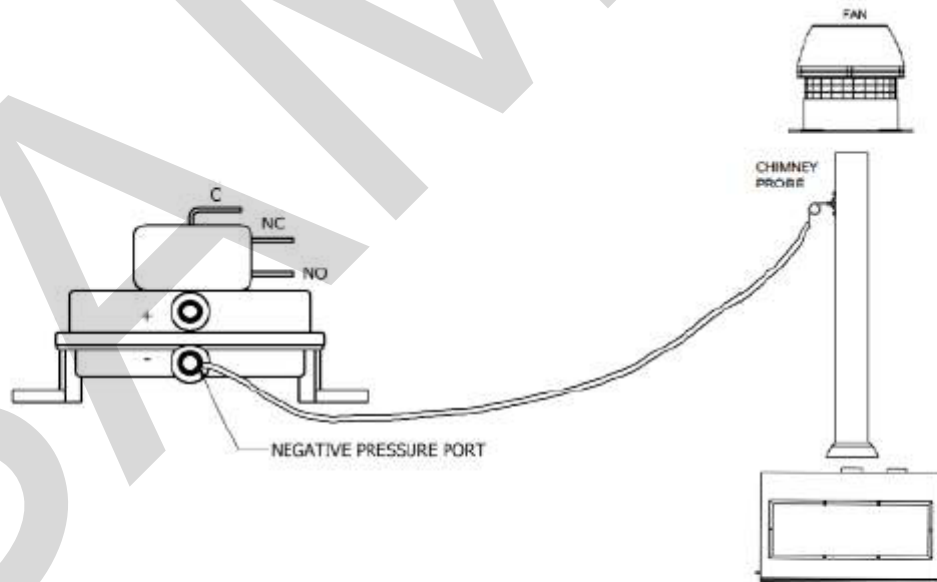

Date Issued:	Project No:	Client	Report No:	Revision No:
December 11, 2017	14563	Acucraft Fireplaces	14563-7G	0

SUPPLEMENTAL MATERIAL

Gas Valve & Ignition Module

Application

Pilot burners provide main burner ignition for standing pilot natural and LP gas systems. Used with a thermocouple to provide automatic pilot safety control. Used with a thermopile in a self-powered system. See Table 1 for model specifications.

TABLE 1—MODEL SPECIFICATIONS.

Model	Primary Aerated	Type of Orifice	Pilot Tip Type	Includes
Q314A	No	Insert	Target	Includes natural and LP gas orifices, 1/4 in. compression fitting, "F," "K," or "L" tip styles, "B" mounting bracket, and "A" mounting bracket adapter.
Q327A	Yes	Spud	Target	Includes natural and LP gas orifices, 1/4 in. compression fitting, and "B" mounting bracket with screws.

Installation

WHEN INSTALLING THIS PRODUCT...

1. Read these instructions carefully. Failure to follow instructions can damage product or cause a hazardous condition.
2. Check ratings given in instructions and on product to make sure product is suitable for your application.
3. Make sure installer is a trained, experienced service technician.
4. After completing installation, use these instructions to check out product operation.

⚠ WARNING

FIRE OR EXPLOSION HAZARD CAN CAUSE PROPERTY DAMAGE, SEVERE INJURY, OR DEATH

Follow these warnings exactly.

1. Disconnect power supply before wiring to prevent electrical shock or equipment damage.
2. To avoid dangerous accumulation of fuel gas, turn off gas supply at appliance service valve before starting installation and perform Gas Leak Test after completion of installation.
3. Do not bend pilot tubing at the control or pilot after compression nut has been tightened. Gas leakage at the connection may result.

Follow appliance manufacturer's instructions if available; otherwise, use instructions provided below.

LOCATION

1. Position pilot burner for easy access, observation, and lighting. In replacement applications, replace pilot burner

with an identical unit and position new pilot burner in the same location and orientation as the original pilot burner.

2. Mount pilot burner on main burner. Mounting surfaces other than the main burner can shift, bend, or warp as furnace expands and contracts while operating. See Fig. 1.
3. Mount pilot burner so the ignition flame remains properly positioned with respect to the main burner flame. See Fig. 2.
4. Supply pilot flame with ample air free of combustion products.
5. Do not impinge pilot flame on adjacent parts. Do not impinge main burner flame on pilot burner.
6. Do not expose pilot flame to falling scale which could impair ignition of main burner.
7. Do not expose pilot burner to main burner rollout while igniting or extinguishing.
8. Do not expose pilot flame to drafts that push or pull pilot flame away from the thermocouple or thermopile.

Fig. 1—Mount pilot burner on main burner.

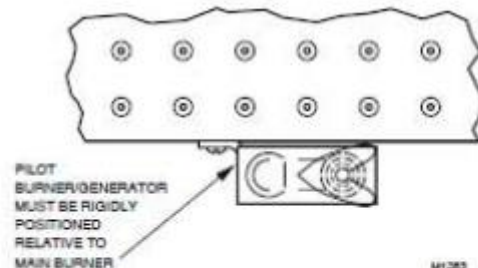

Date Issued:	Project No:	Client	Report No:	Revision No:
December 11, 2017	14563	Acucraft Fireplaces	14563-7G	0

SUPPLEMENTAL MATERIAL

Gas Valve & Ignition Module

Fig. 2—Location of pilot burner.

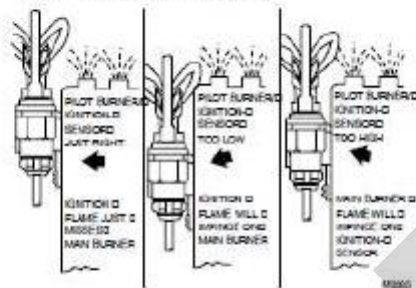

CONNECT PILOT GAS TUBING

1. Cut tubing to desired length and bend as necessary for routing to pilot burner. Do not make sharp bends or deform tubing. Do not bend tubing at control after compression nut has been tightened, as this can result in gas leakage at connection.
2. Square off and remove burrs from end of tubing.
3. Push tubing into compression nut clearance hole until tubing bottoms.

NOTE: When replacing a pilot burner or orifice, cut off old compression fitting and replace with new compression fitting provided with new pilot burner. Never use old compression fitting as it may not provide a gas-tight seal. See Fig. 3.

4. While holding tubing all the way in, engage threads and turn until finger tight.
5. Using a wrench, turn compression nut one turn beyond finger tight. **DO NOT OVERTIGHTEN.**
6. Connect other end of tubing to gas control according to gas control manufacturer instructions.

Fig. 3—Always use new compression fitting.

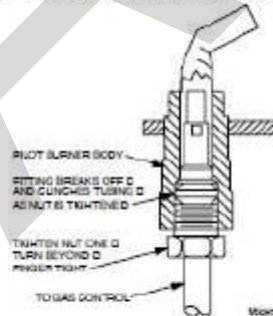

INSTALL THERMOCOUPLE OR THERMOPILE PUSH-IN DESIGN

1. Insert thermocouple or thermopile tip into hole or barrel provided beneath pilot burner. See Fig. 4.
2. Push in firmly until thermocouple or thermopile is locked into place.

ATTACHMENT NUT DESIGN

1. Insert thermocouple or thermopile tip into hole or barrel provided beneath pilot burner. See Figs. 4 and 5.
2. Engage attachment nut threads and tighten until thermocouple or thermopile is locked into place.

Fig. 4—Installing thermocouple or thermopile.

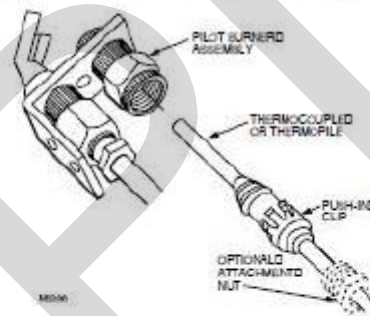
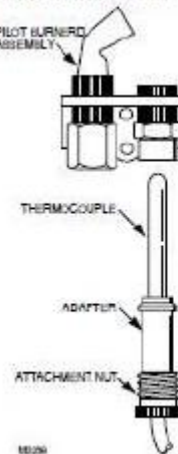

Fig. 5—Installing Q390 Thermocouple.

SCREW-IN TYPE



INSTALL BLEED GAS TUBING (if used):

1. Route bleed gas tubing from bleed tapping on gas control to the pilot burner.
2. Push clip into place. See Fig. 6.
3. Insert bleed gas tubing until 3/8 inch (10 mm) of tubing is above pilot burner bracket. Tip of bleed gas tubing must not extend into pilot flame.

INSTALL "A" MOUNTING BRACKET ADAPTER (optional)

To convert mounting bracket from "B" mounting bracket to "A" mounting bracket, install the "A" mounting bracket adapter to the pilot burner mounting bracket. Then install pilot burner to main burner.

Date Issued:	Project No:	Client	Report No:	Revision No:
December 11, 2017	14563	Acucraft Fireplaces	14563-7G	0

SUPPLEMENTAL MATERIAL

Gas Valve & Ignition Module

Fig. 6—Bleed gas tube installation.

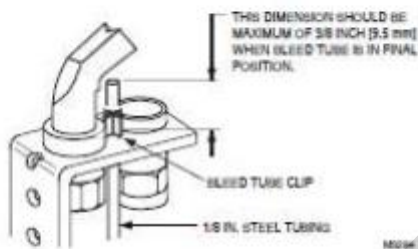
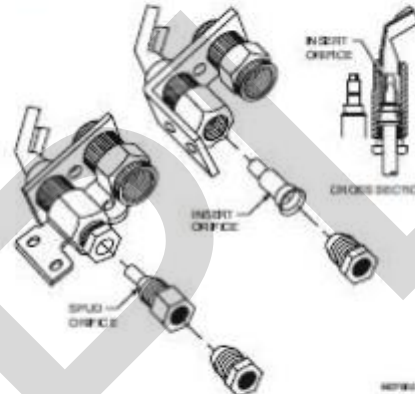

Fig. 7—Changing spud and insert orifices.



CHANGE INSERT ORIFICES (See Fig. 7)

1. Disconnect pilot tubing from the pilot burner and remove insert orifice. Sometimes a light force is required to remove the orifice.
2. Cut off old compression fitting.

NOTE: When replacing an orifice, cut off old compression fitting and replace with a new compression fitting. Never use old compression fitting as it may not provide a gas-tight seal. See Fig. 3.

3. Square off end of pilot tubing and remove all burrs.
4. Insert new compression nut over pilot tubing and slide out of the way.
5. Insert new orifice into pilot burner and push pilot tubing into the pilot burner until it bottoms.
6. While holding tubing all the way in, slide compression fitting into place and engage threads. Turn until finger tight.
7. Using a wrench, tighten compression fitting one turn beyond finger tight.

CHANGE SPUD ORIFICES (See Fig. 7)

1. Disconnect pilot tubing from orifice.
2. Unscrew old spud orifice and discard.
3. Cut off old compression fitting.

NOTE: When replacing an orifice, cut off old compression fitting and replace with a new compression fitting. Never use old compression fitting as it may not provide a gas-tight seal. See Fig. 3.

4. Square off end of pilot tubing and remove all burrs.
5. Insert new compression nut over pilot tubing and slide out of the way.
6. Insert new orifice into pilot burner and tighten securely.
7. Push pilot tubing into orifice until it bottoms.
8. While holding tubing all the way in, slide compression fitting into place and engage threads. Turn until finger tight.
9. Using a wrench, tighten compression fitting one turn beyond finger tight.

Startup and Checkout

PERFORM GAS LEAK TEST



WARNING

**FIRE OR EXPLOSION HAZARD
CAN CAUSE PROPERTY DAMAGE,
SEVERE INJURY, OR DEATH**

Check for gas leaks with soap and water solution any time work is done on a gas system.

GAS LEAK TEST:

1. Ensure that gas supply is turned on at the appliance service valve.
2. Paint pipe connections upstream of pilot burner with rich soap and water solution. Bubbles indicate gas leak.
3. If leak is detected, tighten pipe connections.
4. Stand clear of main burner while lighting to prevent injury caused from hidden leaks which could cause flashback in the appliance vestibule. Light main burner.
5. With main burner in operation, paint pipe joints (including adapters) and gas control inlet and outlet with rich soap and water solution.
6. If another leak is detected, tighten adapter screws, joints, and pipe connections.
7. Replace part if leak can not be stopped.

ADJUST PILOT FLAME

The pilot flame should envelop 3/8 to 1/2 in. [10 to 13 mm] of the thermocouple or thermopile tip. See Fig. 8. To adjust pilot flame:

1. Remove pilot adjustment cover screw from gas control.
2. Turn inner pilot adjustment screw clockwise ↻ to decrease or counterclockwise ↻ to increase pilot flame.
3. Always replace pilot adjustment cover screw and tighten firmly after completing adjustment to ensure proper operation.

Date Issued:	Project No:	Client	Report No:	Revision No:
December 11, 2017	14563	Acucraft Fireplaces	14563-7G	0

SUPPLEMENTAL MATERIAL

Gas Valve & Ignition Module

Fig. 8—Thermocouple or thermopile tip must be in pilot flame.

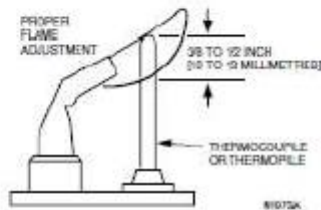

IGNITE PILOT BURNER

1. Before lighting pilot burner, turn thermostat to its lowest setting. Wait for unburned gas to vent.

NOTE: LP gas is heavier than air and will not vent upward. Small for LP gas next to floor. If you smell gas, shut off the main valve in the gas piping, or, ONLY LP, AT THE TANK. Perform Gas Leak Test to rereck all connections.

2. Light pilot burner according to appliance manufacturer's instructions.

Service

WARNING

**FIRE OR EXPLOSION HAZARD
CAN CAUSE PROPERTY DAMAGE,
SEVERE INJURY, OR DEATH**
Perform Gas Leak Test anytime work is done to the system.

PILOT OUTAGE

1. If pilot flame goes out during normal operation, but is properly adjusted, rereck Mounting and Location instructions on page 1.

2. If all mounting and location instructions are followed but pilot continues to go out, construct shielding to protect pilot flame from main burner ignition and extinction and drafts. See Fig. 9.

3. Check pilot flame characteristics.

- Check the pilot flame with the main burner operating.
- Ensure the pilot flame continuously covers the tip of the thermocouple or thermopile, the spark gap and 3/8 to 1/2 in. [10 to 13 mm] of the ground rod. See Fig. 8.
- Ensure the pilot flame is blue (a yellow tipped flame is acceptable on LP systems), soft and steady. See Fig. 9 for examples of possible pilot flame problems and their causes.
- If pilot burner is damaged, replace it with an identical pilot burner and mount and position in the same location and orientation.

Fig. 9—Examples of unsatisfactory pilot flames.

APPEARANCE	CAUSE
SMALL BLUE FLAME 	CHECK FOR LACK OF GAS FLOW: + CLOGGED ORIFICE FILTER + CLOGGED INLET FILTER + LOW GAS SUPPLY PRESSURE + PILOT ADJUSTMENT AT MINIMUM
LAZY YELLOW FLAME 	CHECK FOR LACK OF AIR FLOW: + LARGE ORIFICE + BERRY LINE OBSTRUCTION, IF USED + BERRY PRIMARY AIR OPENING, IF THERE IS ONE + PILOT ADJUSTMENT AT MINIMUM
WAVING BLUE FLAME 	CHECK FOR: + EXCESSIVE DRAFT AT PILOT LOCATION + RECIRCULATING PRODUCTS OF COMBUSTION
NOISE LIFTING BLOWING FLAME 	CHECK FOR: + HIGH GAS PRESSURE
HARD SHARP FLAME 	THIS FLAME IS CHARACTERISTIC OF MANUFACTURED GAS. CHECK FOR: + HIGH GAS PRESSURE + ORIFICE TOO SMALL

PILOTSTAT SAFETY CONTROL POWER UNIT FAILURE

1. Ensure pilot flame is properly adjusted.
2. Ensure power unit connections clean and tight.
3. If power unit still fails to hold in, use the W129A Millivoltmeter to obtain the open and closed circuit voltage generated by the thermocouple or generator.
4. Compare measured open and closed circuit voltage values to Acceptable Range Charts in W129A Manual.
5. If W129A Millivoltmeter or other meter is not available, replace thermocouple or thermopile. If this does not correct the condition, replace power unit.

THERMOCOUPLE OR THERMOPILE PERFORMANCE

Thermocouples and thermopiles require proper temperature differential between the hot-junction (tip) and cold-junction (base) to provide satisfactory operation of gas controls. Thermocouples and thermopiles perform less effectively when exposed to excessive cold-junction or hot-junction temperatures.

Excessive cold-junction temperatures can be caused by heat radiation from adjacent surfaces or high ambient air temperatures. Excessive cold-junction temperatures can be eliminated by shielding the pilot flame, see Fig. 10, or constructing a baffle to direct secondary air over the pilot burner base.

Excessive hot-junction temperatures can be eliminated by proper pilot flame adjustment. To adjust pilot flame, see Adjust Pilot Flame section.

Date Issued:	Project No:	Client	Report No:	Revision No:
December 11, 2017	14563	Acucraft Fireplaces	14563-7G	0

SUPPLEMENTAL MATERIAL

Gas Valve & Ignition Module

Fig. 10—Proper shielding of pilot flame.

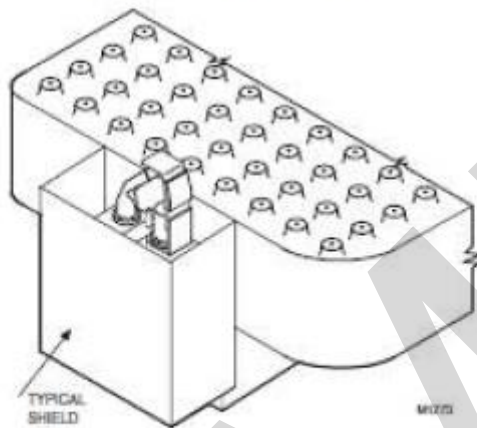

PILOT TURNDOWN TEST (30 mV safety control systems)

The Pilot Turndown Test assures that the pilot flame ignites the main burner within four seconds from the time gas reaches the main burner. In this test, the pilot flame is just sufficient enough to hold in the power unit or just above the point of flame extinction (whichever occurs at a higher pilot gas flow rate).

1. With the pilot and main burner operating, shut off the main burner by either lowering the thermostat temperature setting or turning the gas control knob to the PILOT position.

NOTE: If using a Honeywell W129A Millivoltmeter, turn the pilot gas adjustment screw until the thermocouple open circuit voltage is 2 mV. Omit steps 2,3, and 4 and proceed with step 5.

2. Turn the pilot gas adjustment screw clockwise until the pilot begins to decrease in size. Then, turn the pilot gas adjustment screw clockwise 1/4 turn a time (waiting one minute between each turn to allow the thermocouple to cool) until safety shutoff power unit just drops, causing safety shutdown.

3. Turn pilot gas adjustment screw counterclockwise slightly.
4. Relight pilot burner. The power unit should hold in.
5. Turn gas control knob to ON position and set thermostat temperature setting above room temperature. Main burner should light within four seconds without flame rollout. If not, check pilot mounting and location instructions in Location section and repeat Pilot Turndown Test.
6. Readjust pilot burner flame. See Adjust Pilot Flame section.

EFFECTIVE IGNITION TEST (750 mV SYSTEMS)

The Effective Ignition Test assures that the pilot flame ignites the main burner within four seconds from the time gas reaches the main burner. In this test, the pilot flame is just sufficient to open the main gas valve.

1. Light the main burner according to the appliance manufacturer's instructions and allow to burn at least five minutes.
2. Remove one thermostat lead (TH) at the gas control terminal.
3. Using the pilot gas adjustment screw, decrease the pilot flame until it begins to pull away from the thermopile. Allow thermopile to cool for one minute.
4. Temporarily jumper the thermostat terminals (TH) on the gas control.
5. If the main burner ignites, reduce the pilot flame by turning the pilot adjustment screw 1/4 turn at a time until the valve fails to pull in. Allow the thermocouple to cool at least one minute between each reduction in the pilot flame level.
6. Increase the pilot flame just enough to pull in the gas control main valve.
7. Jumper the thermostat terminals. The main burner should light within four seconds and without flame roll-out. If it does not, check the Location and Mounting instructions on page 1 and repeat steps 1 through 6.
8. If main burner still does not light, replace thermopile and repeat steps 1 through 6.
9. Remove the jumper to shut off the main burner.
10. Readjust pilot burner flame. See Adjust Pilot Flame section.
11. Reconnect the thermopile lead and ensure all connections are correct and the system is functioning properly.

Date Issued:	Project No:	Client	Report No:	Revision No:
December 11, 2017	14563	Acucraft Fireplaces	14563-7G	0

SUPPLEMENTAL MATERIAL

Draft Switch

Mechanical Installation

INSTALLATION OF DRAFT SWITCH

The Draft Switch is for indoor installation only. The Draft Switch must be installed in a vertical position with the pressure connection pointing down. Secure the switch by using the mounting holes as shown on the gure. After installation connect the tubing from the probe onto the port marked accessible through the small of the plastic enclosure. Connect tubing to the **NEGATIVE (-)** port on the Draft Switch.

Factory wiring comes with three wires that are already crimped onto the Draft Switch. The purpose of these wires is to provide a point in which you can extend the length of the wire by using wire nuts and additional wire (not provided).

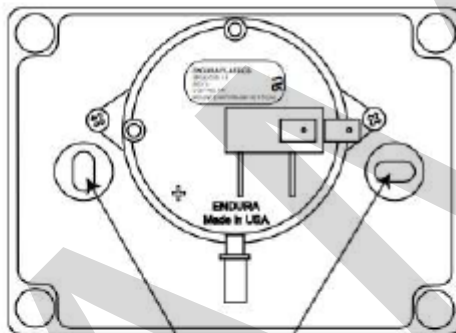

Mounting holes

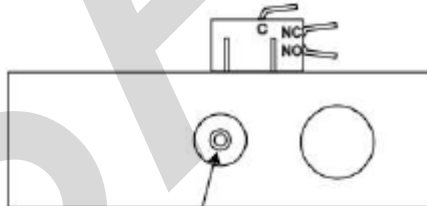

Connection for tubing at the bottom of the enclosure

INSTALLATION OF STACK PROBE FOR PDS 1:

A stack probe is used with Draft Switch. The Draft Switch monitors the pressure inside the stack and signals the control to shut down the appliance if insufficient draft exists inside the stack. The probe must be installed between the appliance and the exhaust fan.

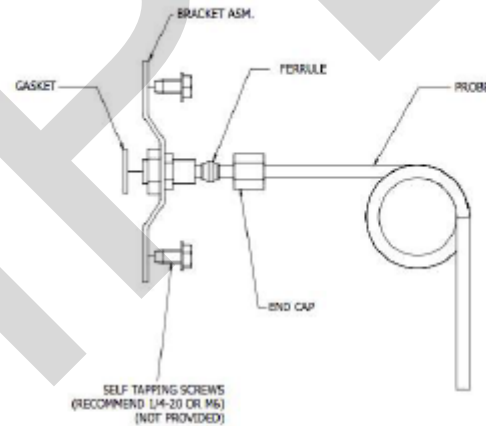

For all installations, the stack probe must be placed so the flow through the stack is perpendicular to the tip of the probe. Locate the probe at least the distance "A" away from any elbows or tees in the stack.

The distance "A" is designed as at least three (3) vent diameters; $A \geq 3 * V$ (see figure below). To prevent condensation from entering the probe or Draft Switch when installed on a horizontal stack, the probe must be installed above the centerline of the stack. For replace installations, the stack probe should be installed as close to the exhaust fan as possible.

Date Issued:	Project No:	Client	Report No:	Revision No:
December 11, 2017	14563	Acucraft Fireplaces	14563-7G	0

SUPPLEMENTAL MATERIAL

Draft Switch

For all installations, the stack probe must be placed so the flow through the stack is perpendicular to the tip of the probe. Locate the probe at least the distance "A" away from any elbows or tees in the stack. The distance "A" is designed as at least three (3) vent diameters; $A \geq 3 * V$ (see figure below). To prevent condensation from entering the probe or Draft Switch when installed on a horizontal stack, the probe must be installed above the centerline of the stack. For replace installations, the stack probe should be installed as close to the exhaust fan as possible.

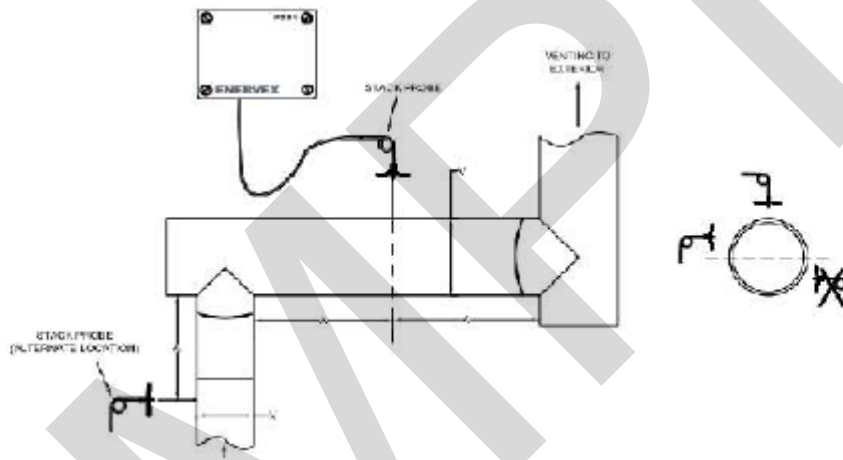

Mechanical Installation (cont.)

INSTALLATION OF STACK PROBE FOR Draft Switch (cont.):

For the Draft Switch to function properly, the probe must be placed in a location that can produce at least 0.05 in/WC in the stack. In order to produce an accurate pressure reading, the tip of the probe must be mounted flush with the inside of the stack wall (it should never extend more than 1/16" beyond the wall). For a double walled stack, the tip should be flush with the inner most wall.

To mount the probe, drill a clearance hole through the stack wall(s). Insert the probe and attach the bracket to the stack using (2) customer provided self-tapping machine screws. Tighten the end cap to compress the ferrule and permanently install the stack probe. Attach the supplied silicon tubing at the other end of the probe.

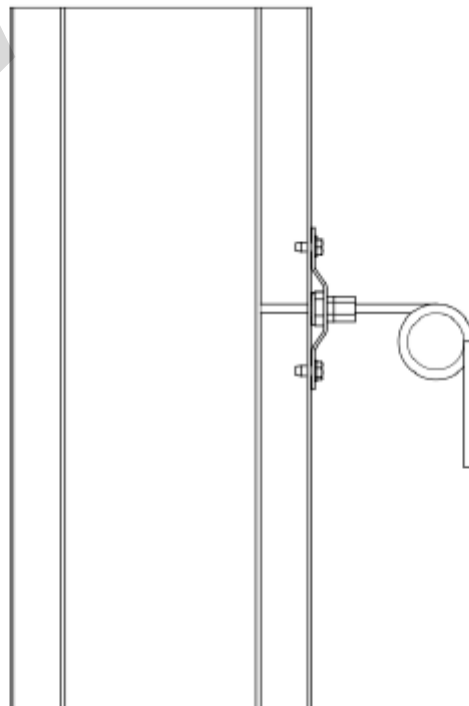

Date Issued:	Project No:	Client	Report No:	Revision No:
December 11, 2017	14563	Acucraft Fireplaces	14563-7G	0

SUPPLEMENTAL MATERIAL

Inline Fan

Installation and Maintenance

INSTALLATION (cont.):

DIMENSION MODEL FG Dimensions in in

Model	A	C	D	E	F
8, 8XL	8	13 ³ / ₈	6	1 ¹ / ₈	1 ¹ / ₈

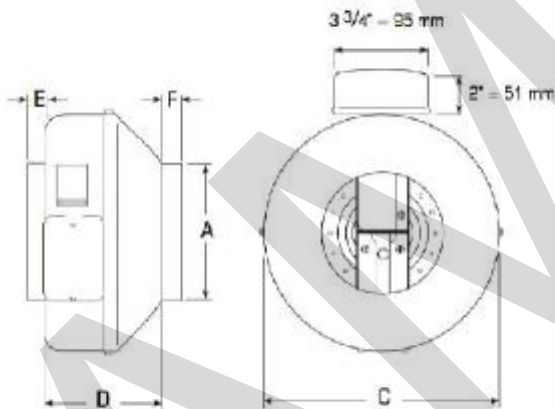

WIRING:

! CAUTION

All installation should be wired according to the following diagrams.
Failure to comply will cause the motor to "hum" or not work.

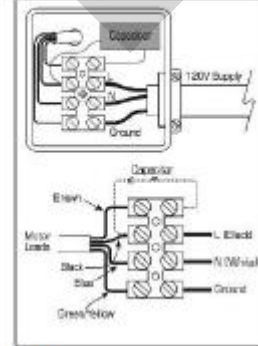

Instruction for all model FG fans

With motor speed controller

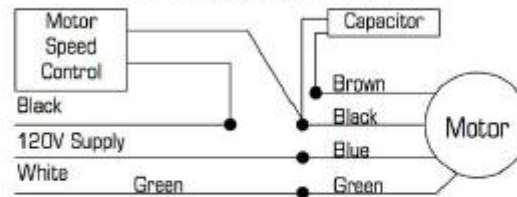

Without motor speed controller

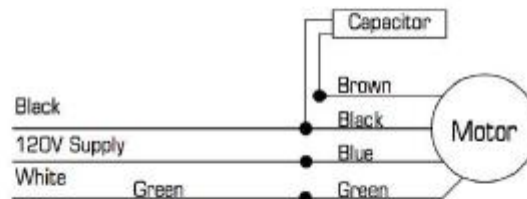

Date Issued:	Project No:	Client	Report No:	Revision No:
December 11, 2017	14563	Acucraft Fireplaces	14563-7G	0

SUPPLEMENTAL MATERIAL

Chimney Fan

Dimensions & Capacities

Model	Chimney Fan
Discharge	Horizontal
Fan Type	Axial Vane
Motor Type	Totally enclosed, variable speed, Class H
Voltage (VAC)	1 x 120
RPM	1600
CFM (0.0Ps)	450
Amperage (Amps)	0.5
Motor Output (HP)	1/30
Motor Output (kW)	0.025
Weight (lbs)	29
Weight (kg)	13
Dimensions A (In)	10.2
Dimensions A (mm)	259
B x B (In)	11.7
B x B (mm)	296
C (In)	10.8
C (mm)	275
D (In)	3.0
D (mm)	75
E (In)	9.4
E (mm)	238
Temperature (Intern.)	575°F/300°C

Sound Data:

Lw dB (measured in accordance with ISO 3744)							Lp dB(A)
125Hz	250Hz	500Hz	1000Hz	2000Hz	4000Hz	8000Hz	
54	50	47	43	38	31	25	21

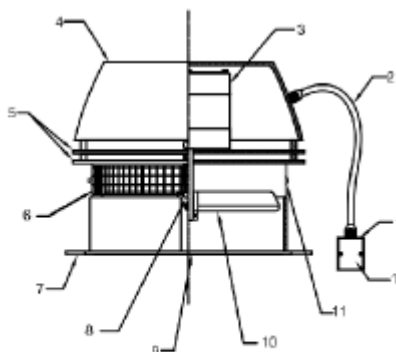
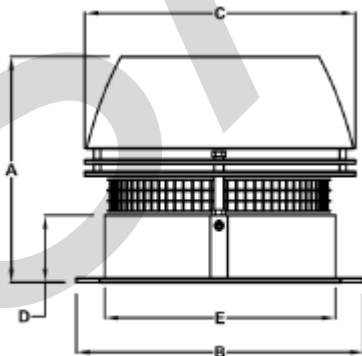

1. Junction Box
2. Conduit / Cord
3. Motor
4. Motor Housing
5. Cooling Plates
6. Bird Screen
7. Base Plate
8. Locking Nut
9. Inlet
10. Axial Vane
11. Hinges
12. Capacitor (Inside Junction Box)

LISTING REPORT

Date Issued:	Project No:	Client	Report No:	Revision No:
December 11, 2017	14563	Acucraft Fireplaces	14563-7G	0

SUPPLEMENTAL MATERIAL

Chimney Fan

Planning Ahead

WARNING

1. Observe proper combustion air requirements.
2. Provide a firm support system for the chimney fan.
3. Determine the type of system involved.
4. Observe proper safety measures are taken to assure safe use of the wood burning appliances.

Support system for the chimney fan: Prior to installation of the chimney fan, it must be assured the chimney can safely carry the weight of the chimney fan.

A steel chimney should be well supported at the roof penetration point.

Combustion Air Requirements: Provisions for combustion air must be in accordance with applicable local codes.

If the heating system is installed in an unconfined space, adequate air will be available via normal infiltration.

If the heating system is installed in a confined space, (a space with a volume less than 50 cubic feet per 1,000 Btu/hr of input for all fuel burning equipment) or building construction is unusually tight, adequate air for combustion must be provided by two openings: one located about 6" below the ceiling, the other about 6" above the floor. Each opening must have a minimum free area as follows:

1. One square inch per 2,000 Btu/hr when communication through horizontal ducts to the outside.
2. One square inch per 1,000 Btu/hr when ventilation air is provided by openings in doors, etc. to adjoining spaces having adequate infiltration.

WARNING

Adequate fresh air must be provided for combustion; otherwise, improper operation and inadequate venting of deadly flue gases may result.

Date Issued:	Project No:	Client	Report No:	Revision No:
December 11, 2017	14563	Acucraft Fireplaces	14563-7G	0

SUPPLEMENTAL MATERIAL

Chimney Fan

Single Fan on Steel Chimney

Step 1: Prepare fan location

The steel chimney adapter (SCA) slides right into the chimney, where the long collar engagement ensures safe anchoring.

Step 2: Preparation of fan

Locate the installation brackets in the grooves on the underside of the fan base, using the bolts and nuts supplied to secure the brackets. Note that the bolts shall be installed from the bottom side in the two inner holes.

Adjust the final position of the installation brackets ensuring that there is a small gap between the brackets and the flue wall/adapter throat. Tighten the nuts. If the brackets touch the flue wall, it may create some vibration noise.

Step 3: Attaching the fan

The chimney fan is now ready for installation on the top of the chimney. It is not necessary to bolt the fan to the chimney.

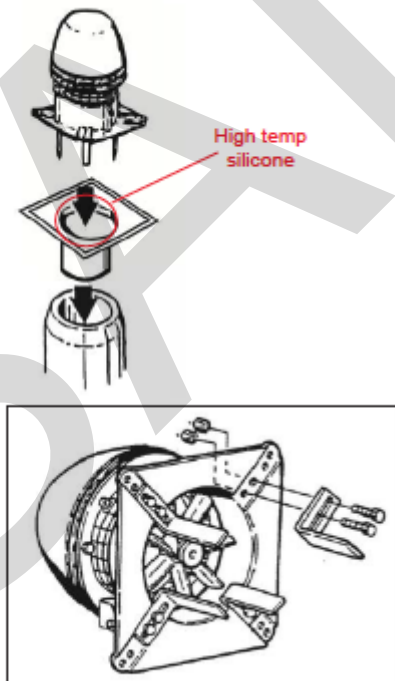

! CAUTION

Under conditions with extremely strong winds surrounding the top of the chimney, the chimney fan must be secured by steel wires supplied with the fan.

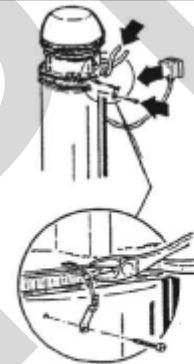

Wall Mounting of Chimney Fan

When mounting the chimney fan on a wall, the installation instructions for installation on a steel chimney should be followed. Use of the adapter SCA can make the installation easier.

To ease installation, detach the fan base by removing the bolts holding the hinges together. Center the fan base over the outlet and bolt the base onto the wall with the hinges pointing upwards.

After mounting the base securely, attach the fan motor housing by reassembling the fan hinges. Seal with high temp silicone all around the edges.

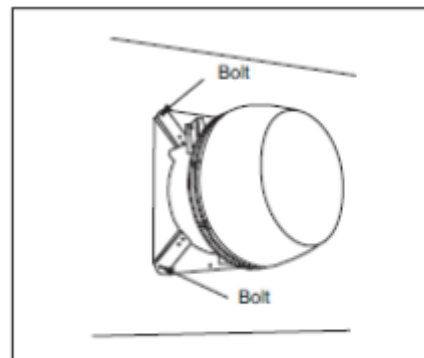

Date Issued:	Project No:	Client	Report No:	Revision No:
December 11, 2017	14563	Acucraft Fireplaces	14563-7G	0

SUPPLEMENTAL MATERIAL

Chimney Fan

CAUTION

A safety device that prevents the heating appliance operation, in case of a power failure or inadequate draft situation, must be installed.

Termination of Venting System

In order to achieve optimal performance and energy consumption for the RS Fan the duct must be installed as shown below and the distances observed. From the last elbow to the termination point the distance has to be 3 times the diameter of the flue. For example if you using 12in flue (12 X 3 = 36in). So the distance from the last elbow to the fan termination point should be 36 inches.

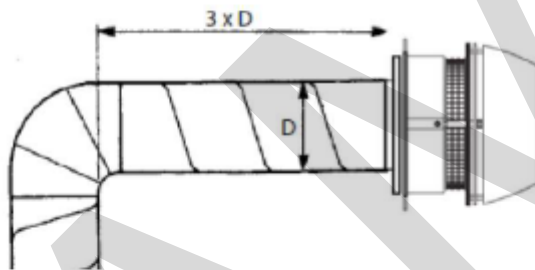

A venting system that terminates in the sidewall of a structure shall terminate at least 3 ft (0.9 m) above any air inlet to the structure that is within 10 ft (3 m) of the termination point.

Exception No. 1: This requirement shall not apply to the combustion air intake of a direct vent appliance.

Exception No. 2: This requirement shall not apply to the separation distance between the circulating air inlet and the vent discharge of a listed outdoor appliance.

The flue gas outlet of an appliance other than a direct vent appliance shall terminate at least 4 ft (1.2 m) below, 4 ft (1.2 m) horizontally from, or 1 ft (0.3 m) above any door, window, or gravity air inlet of the structure. The outlet also shall terminate at least 1 ft (0.3 m) above grade.

The combustion air inlet and flue gas outlet of a direct vent appliance or the flue gas outlet of an appliance other than a direct vent appliance shall terminate at least 1 ft (0.3 m) from the soffit of the roof of the structure and at least 3 ft (0.9 m) from an inside corner of an L-shaped structure.

The flue gas outlet terminal of a direct vent application with an input of 50,000 Btu/hr (0.35 gal/hr) or less shall be located at least 9 in. (230 mm) from any door, window, or air inlet to the structure. The vent terminal of a direct vent appliance with an input over 50,000 Btu/hr (0.35 gal/hr) shall be located at least 1 ft (0.3 m) from any door, window, or air inlet to the structure. Regardless of input, the flue gas outlet terminal shall also terminate at least 1 ft (0.3 m) above grade.

The exit terminals of mechanical draft systems shall not be less than 7 ft (2.1 m) above grade when located adjacent to public walkways.

Any air inlet and any flue gas outlet of any appliance shall terminate at least 5 ft (1.6 m) from the vent outlet of a supply tank.

Electrical Installation

WARNING

Turn off electrical power before servicing. Contact with live electric components can cause shock or death.

All electrical wiring must be in accordance with requirements of authority having jurisdiction or, in absence of such requirements, with National Electrical Code NFPA 70 — latest edition. If an external electrical source is utilized, system must be electrically grounded in accordance with requirements of the authority having jurisdiction or, in the absence of such requirements, with the National Electrical Code NFPA 70 — latest edition.

Date Issued:	Project No:	Client	Report No:	Revision No:
December 11, 2017	14563	Acucraft Fireplaces	14563-7G	0

SUPPLEMENTAL MATERIAL

Chimney Fan

Start-Up and Configuration

SYSTEM TESTING

Before any adjustments are made to the system, follow these procedures:

1. Turn the chimney fan ON and make sure that it is operating. Increase and decrease the speed of the fan by adjusting the fan speed control to make sure it is operating properly.
2. Turn the fan OFF and make sure the pressure switch opens, so the power to the circuit, it controls, is disconnected.

CARE AND CLEANING

The Chimney Fan System is designed for prolonged use. The fan should be inspected at least once a year when the chimney is inspected. Fuel residues and other deposits should be removed from the fan blades and the bottom of the motor housing. The top of the fan is hinged and can be opened in order to ease the cleaning.

! WARNING

Check other heating appliances (water heater, furnace, fireplace etc.) for proper operation while the chimney fan is operating. Make sure no flue gases are spilling out as this can lead to carbon monoxide poisoning.

! WARNING

Do not open the motor housing unless power to the chimney fan has been disconnected.

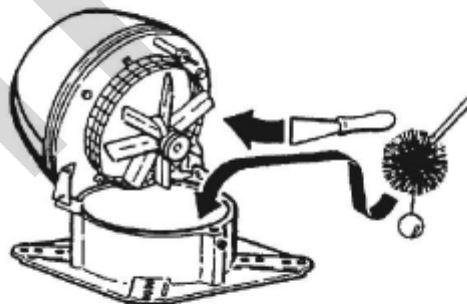

Maintenance

PRIOR TO CLEANING

Remove butterfly nut or screw from each hinge prior to cleaning.

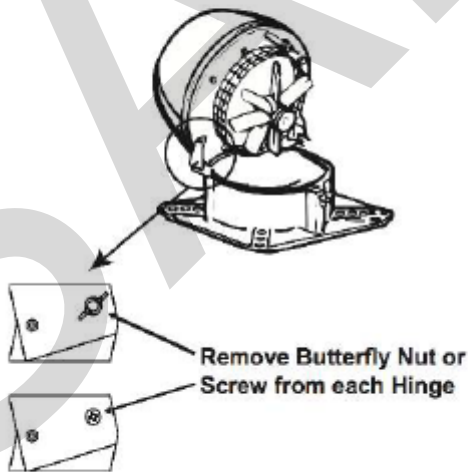

Date Issued:	Project No:	Client	Report No:	Revision No:
December 11, 2017	14563	Acucraft Fireplaces	14563-7G	0

SUPPLEMENTAL MATERIAL

Chimney Fan

Maintenance (cont.)

CHIMNEY CLEANING INTERVALS

It is extremely important to keep the chimney flue clean from products of combustion and deposits. Unburned oil residues can cause a chimney fires.

Cleaning intervals depend on the use of the appliance. The more the appliance is used, the more often the chimney flue needs cleaning. As there are no firm guidelines for cleaning intervals, have the chimney inspected on a regular basis (every quarter or so) to determine what the interval should be. Then follow this interval.

No matter how much used, a chimney flue should be cleaned and inspected at least once every year.

NOTE: The chimney should be cleaned by a trained professional. We recommend using a "Certified Chimney Sweep" certified by Chimney Safety Institute of American. You can find a Certified Chimney Sweep at www.csia.org or www.ncsg.org or by calling (317) 837-5362 or (317) 837-1500.

Troubleshooting

OBSERVATION	PROBLEM	SOLUTION
There is no power going to the fan	<ul style="list-style-type: none"> - The circuit breaker may be off - Fan speed control is off - Bad electrical connections 	<ul style="list-style-type: none"> - Check the circuit breaker - Turn fan speed control on - Check and correct problem
There is power to the fan but it is not operating	<ul style="list-style-type: none"> - Bad electrical connections - The fan speed control's low voltage setting is too low - The fan speed control is bad 	<ul style="list-style-type: none"> - Check and correct problems with connections. Pay special attention to the wiring in the junction box - Increase the setting with the plastic screw on the fan speed control's front plate - Replace the fan speed control
There is power to the fan but it hums and does not turn	<ul style="list-style-type: none"> - The motor run capacitor may be bad. - Creosote may stick 	<ul style="list-style-type: none"> - Check capacitor and replace if necessary - Clean fan
The fan seems to work fine, but there is not enough draft	<ul style="list-style-type: none"> - The fan may be undersized 	<ul style="list-style-type: none"> - Replace with a larger fan
The fan vibrates	<ul style="list-style-type: none"> - The motor shaft may be bent - The hinges may be bent 	<ul style="list-style-type: none"> - Replace motor - Straighten out hinges
There is airflow noise from the draft hood	<ul style="list-style-type: none"> - The flue is undersized. - The fan is oversized and running too fast 	<ul style="list-style-type: none"> - There is not much to do about it - Reduce the fan speed
Mechanical noise can be heard	<ul style="list-style-type: none"> - Foreign matter may be stuck - Motor bearings may be worn out 	<ul style="list-style-type: none"> - Remove foreign matter - Replace bearings

LISTING REPORT



Date Issued:	Project No:	Client	Report No:	Revision No:
December 11, 2017	14563	Acucraft Fireplaces	14563-7G	0

NOTES



Blank lined area for notes, overlaid with a large 'SAMPLE' watermark.

LISTING REPORT

Date Issued:	Project No:	Client	Report No:	Revision No:
December 11, 2017	14563	Acucraft Fireplaces	14563-7G	0

PRODUCT SPECIFICATIONS

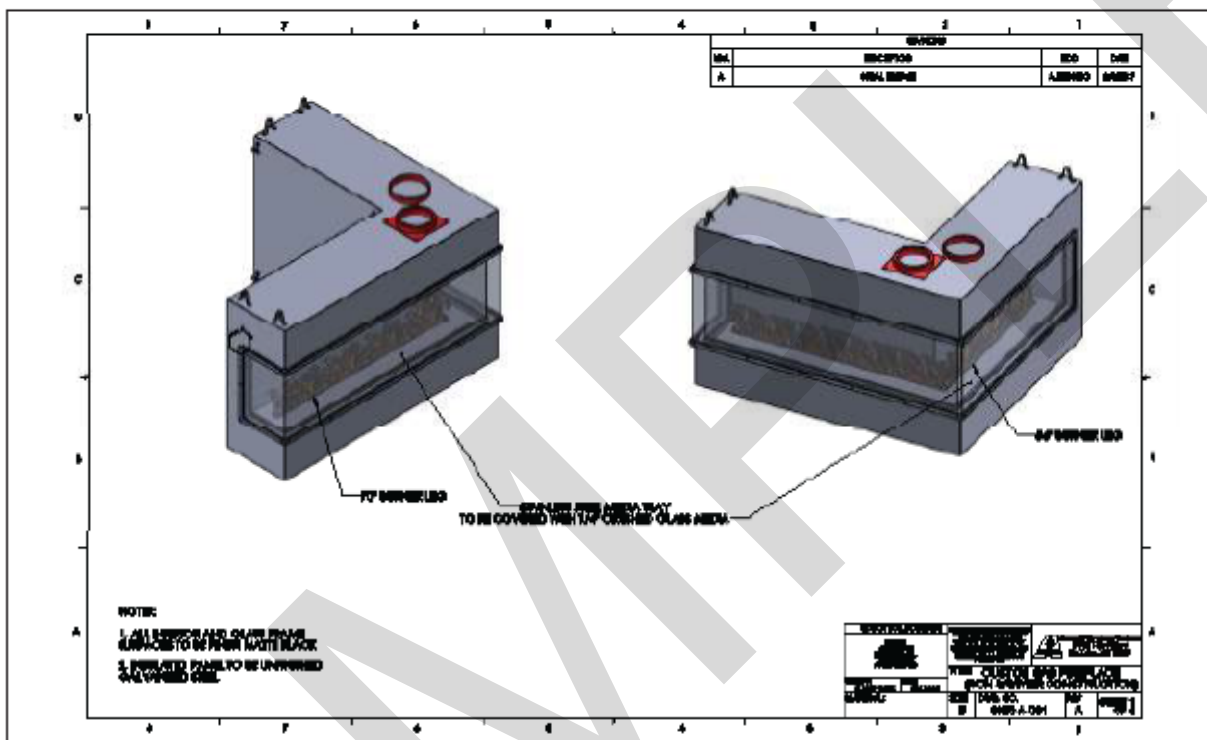

SPECIFICATIONS		
Height = 54 1/2" Width = 90" Depth = 78 3/16" Appx Weight. = 2500lbs Gas Type = Natural Gas Flue Size = 10" Flue Type = 103HT Electrical = Single 15 AMP service	NATURAL GAS Input Rating (BTU/hr) 0-1370 m = 200,000 BTUs/hr. Minimum inlet pressure (in.w.c.) = 7.0 in. W.C. Maximum inlet pressure (in.w.c.) = 10.5 in. W.C. Combustion Air inlet size= Dual 8" Ducts Glass Cooling Air inlet size = Dual 8" Ducts	Based on testing that was performed, the following results have been recorded. Minimum Clearances to combustibles Unit to back wall of enclosure = 2 inches Unit to sidewall of enclosure = 2 inches Unit top to enclosure top = 4 inches NOTE: A 12" B-Vent used as a duct to remove heat from the top to the outdoors must be installed to maintain these clearances. (SUPPLIED BY OTHER)
Note: The chimney flue for the appliance should never be connected to another chimney flue in any way.		

LISTING REPORT

Date Issued:	Project No:	Client	Report No:	Revision No:
December 11, 2017	14563	Acucraft Fireplaces	14563-7G	0

PRODUCT SPECIFICATIONS

MANUFACTURER: VENTED GAS FIREPLACE Serial #/En. Série: 6925 Acucraft Fireplaces MODEL/ MODELE: Acucraft Custom Gas L-Shaped Fireplace 18672 172nd St Big Lake, MN 55309 (763) 263-3156	
GAS TYPE / TYPE DE GAZ: Natural Gas (Gaz naturel) (INPUT RATING (ENTRÉE NOTE) (Btu/hr) 0-610m: 200,000 ORIFICE SIZE (DIMENSIONS DE L'ORIFICE) (DMS) 0-610m: L (INPUT RATING (ENTRÉE NOTE) (Btu/hr) 610-1370m: 200,000 ORIFICE SIZE (DIMENSIONS DE L'ORIFICE) (DMS) 610-1370m: L MANIFOLD PRESSURE (PRESSION D'ADMISSION) (in. w.c.kPa): 0.5(0.9) MINIMUM INLET PRESSURE (MINIMUM PRESSION D'ENTRÉE) (in. w.c.kPa): 7.0(1.74) ELECTRICAL (ÉLECTRIQUE) 120 Vac, less than 2 Amps (Moins de 2 amperes)	
VENTED GAS FIREPLACE. NOT FOR USE WITH SOLID FUEL. NOT FOR USE WITH GLASS DOORS. ÉVACUATION FOYER DE GAZ. NE PAS UTILISER AVEC DES COMBUSTIBLES SOLIDES. NE PAS UTILISER AVEC PORTES EN VERRE.	
Follow installation instruction. Suivez les instructions d'installation.	Minimum clearances to combustibles: Unit to back wall of enclosure: 2 inches Unit to sidewall of enclosure: 2 inches Unit top to enclosure cap: 4 inches
CERTIFIED FOR CANADA / CERTIFIÉ POUR LE CANADA ANSI Z21.60, CSA 2.22-2016 DO NOT REMOVE THIS LABEL N'ENLEVEZ PAS CETTE ETIQUETTE	
Lab Test 	

Date Issued:	Project No:	Client	Report No:	Revision No:
December 11, 2017	14563	Acucraft Fireplaces	14563-7G	0

PRODUCT SPECIFICATIONS

FOR YOUR SAFETY, READ BEFORE OPERATING

WARNING: If you do not follow these instructions exactly, a fire or explosion may result causing property damage, personal injury, or loss of life.

- | | |
|---|--|
| <p>A. This appliance has a pilot. It is equipped with an ignition device which automatically lights the burner. Do <u>not</u> try to light the burner by hand.</p> <p>B. BEFORE OPERATING smell all around the appliance area for gas. Be sure to smell next to the floor because some gas is heavier than air and will settle on the floor.</p> <p style="text-align: center;">WHAT TO DO IF YOU SMELL GAS:</p> <ul style="list-style-type: none"> • Do not try to light any appliance • Do not touch any electric switch; do not use any phone in your building. • Immediately call your gas supplier from a neighbor's phone. Follow the gas supplier's instructions. | <ul style="list-style-type: none"> • If you cannot reach your gas supplier, call the fire department. <p>C. Only use your hand to push in or turn the gas control knob. Never use tools. If the knob will not push in or turn by hand, don't try to repair it, call a qualified service technician. Force or attempted repair may result in a fire or explosion.</p> <p>D. Do not use this appliance if any part has been under water. Immediately call a qualified service technician to inspect the appliance and to replace any part of the control system and any gas control which has been under water.</p> |
|---|--|

OPERATING INSTRUCTIONS

1. STOP! Read the safety information above on this label.
2. Turn off all electric power to the appliance.
3. This appliance is equipped with an ignition system which automatically lights the burner. Do not try to light the burner by hand.

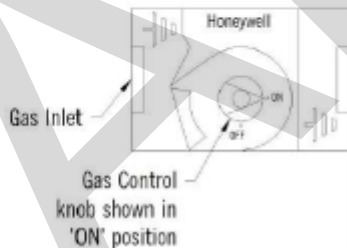

4. Push in gas control knob slightly and turn clockwise to "OFF"

Note: Knob cannot be turned to "OFF" position unless knob is pushed in slightly. Do not force.

5. Wait five (5) minutes to clear out any gas. Then smell for gas, including near the floor. If you smell gas, STOP! Follow "B" in the safety information above on this label. If you don't smell gas, go to the next step.
6. Turn gas control knob counterclockwise to "ON"
7. Replace control access panel.
8. Turn on all electric power to the appliance.
9. If the appliance will not operate, follow the instructions "To Turn Off Gas To Appliance" and call your service technician or gas supplier.

TO TURN OFF GAS TO APPLIANCE

- | | |
|--|--|
| <ol style="list-style-type: none"> 1. Turn off all electric power to the appliance if service is to be performed. 2. Remove control access panel | <ol style="list-style-type: none"> 3. Push in control knob slightly and turn clockwise to "OFF" Do not force 4. Replace control access panel |
|--|--|

LISTING REPORT

Date Issued:	Project No:	Client	Report No:	Revision No:
December 11, 2017	14563	Acucraft Fireplaces	14563-7G	0

OPERATION GUIDE

Basic Sequence of Operation

Listed below is a sequence of operation when the fireplace is functioning properly. If you are experiencing problems with the fireplace not operating normally, see the Troubleshooting section.

1. The fireplace control switch is turned on.
2. A signal is sent to Draft Controller turning on the exhaust fan as well as opening the damper.
3. The Draft Switch proves positive draft within the flue.
 - a. Draft proves (go to step 4)
 - b. Draft doesn't prove and system locks out.
(The process will need to be restarted.)
4. A signal is then sent back to the Draft Controller which then signals the valve module to open and ignite the pilot.
5. The pilot spark igniter will discontinue sparking after flame has been proven.
6. The pilot will then send gas to the burner as well as ignite gas and prove the flame is burning.
7. Operation normal.

Lighting the Ignition System (cont.)

For complete lighting instructions refer to "Lighting Instructions" on page 23

Turning gas off to the appliance

Please check with local codes. In the absence of local codes, use the current National Fuel Gas Code – ANSI Z223.1 (NFPA 54).

Turning the fireplace ON

To turn the fireplace ON refer to "Lighting Instructions" on page 23

Lighting the Ignition System

	WARNING
	Follow the instructions below exactly. Failure to follow this warning may result in serious injury or loss of life.
<p>IMPORTANT: This appliance is equipped with an ignition system which automatically lights the burner. DO NOT try to light the burner by hand. Only use your hand to push in or turn gas control. NEVER use tools. Call a qualified technician. Force or attempted repair may result in fire or explosion.</p>	

Date Issued:	Project No:	Client	Report No:	Revision No:
December 11, 2017	14563	Acucraft Fireplaces	14563-7G	0

DRAFT CONTROL OPERATION

Sequence of Operation

The sequence of operation flow chart is shown in the figure below.

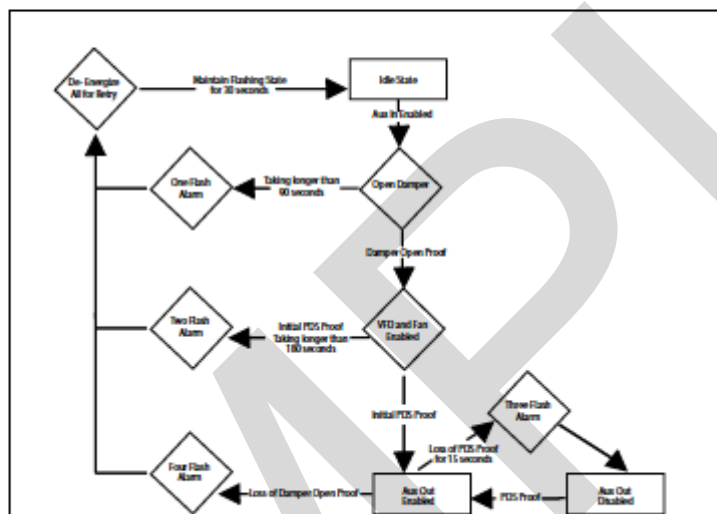

Stages

- Flashes 1 - if damperprove does not close 90 seconds after auxin, go into alarm for 30 seconds, followed by a full retry
- Flashes 2 - if initial pdsprove does not close 180 seconds after damperprove, go into alarm for 30 seconds, followed by a full retry
- Flashes 3 - if pds loses proof for 15 seconds after initial pdsprove, auxouts de-energize, stay in alarm until pdsprove returns and auxout will re-energize
- Flashes 4 - if at any point after auxout proves the damperprove is removed, the board immediately goes into alarm for 30 seconds, followed by a full retry
- Flashes 5 - *must have sw3 on* if pds is proved prior to auxin, board will go into alarm and no further states can be achieved until proof is removed

Start

Sequence

1. A call for heat from the appliance energizes the ADC100 inputs at terminals 9 and 10.
2. If a damper is connected, it begins to open. Once open, the damper prove contact closes (Terminals 16 and 17).
3. The ADC100 begins to ramp up the fan.
4. The Proven Draft Switch closes when adequate draft is achieved and ADC100 adjusts fan to speed setting on the potentiometer.
5. The ADC100 control releases the appliance for operation by closing dry contact between terminals 22 and 23 (and terminals 29 and 30).

Operating Sequence

- Manual Mode:
1. Fan runs at a constant speed and can be adjusted during normal operation using the potentiometer.
 2. If the Proven Draft Switch opens, a 15 second timing cycle starts.
 3. If the Proven Draft Switch has not been made within 15 seconds, the auxiliary out contact opens and an alarm condition exists.
 4. If the Proven Draft Switch closes, the control automatically resumes normal operation at set speed.

Date Issued:	Project No:	Client	Report No:	Revision No:
December 11, 2017	14563	Acucraft Fireplaces	14563-7G	0

TROUBLESHOOTING

PROBLEM	SOLUTION
Appliance does not light within 20 seconds.	<p>If the appliance does not light within 20 seconds, the gas valve will lock out automatically. Turn off switch, wait 10 seconds, and try turning it on again.</p> <p>If there is still no ignition, turn off switch and visually inspect wiring harness for loose connections and check to be sure the gas supply is connected and all valves are open.</p> <p>If the appliance still does not ignite, check the spark igniter to be sure it is operating correctly. It should have a visible spark and make a clicking sound as it sparks.</p> <p>If no spark is seen, verify that all connections are tight and secure at the ignition control module. If it still fails to ignite, the draft proving system may not be activating. Contact a qualified technician to verify that the venting is clear, the exhaust fan is operational, and that the draft proving system is functioning properly. The system will not start the ignition sequence until draft is proven.</p>
Spark Igniter is working, but does not ignite the flame.	It will stop sparking after 11 seconds as a safety, and will then lock out the gas valve. Turn off the switch and try again. If it is still sparking with no ignition, contact a qualified technician.
The appliance ignites, but shuts down shortly after ignition.	<p>The flame sensor may not be registering proper flame strength. Turn the appliance on and visually inspect the spark ignition sequence. If the igniter is still sparking after the flame is burning, it may indicate that the flame sensor rod is not making proper contact with the flames. The flame sensor must be located directly in the flame to get the proper signal. A DC current is created by the flame on the rod that must be present to prove there is a flame or the valve will lock out. If the flame is not making direct contact with the flame sensor, contact a qualified technician to make necessary adjustments.</p> <p>If the flame sensor appears to be red hot and within the flames, yet the igniter keeps sparking, the sensor is not sensing the flame properly and the valve will lock out after 11 seconds. Verify that all electrical connections to the ignition module are tight and secure. If it still does not stay lit, contact a qualified technician.</p>
The flames appear light and lazy on the burner.	Visually compare flame to those shown in the Installing the Media section of this manual. There may be a reduction in gas pressure or a blockage to the venting. Contact a qualified technician to diagnose.

Date Issued:	Project No:	Client	Report No:	Revision No:
December 11, 2017	14563	Acucraft Fireplaces	14563-7G	0

MAINTENANCE & CARE

Always use proper precautions and turn off fireplace before performing any maintenance.

Do not clean appliance when hot.

Clean the tempered glass with a basic household glass cleaner every 3 months to 1 year (depending on frequency of use). Never use abrasive cleaners or glass cleaner that contains ammonia, as it may etch the tempered glass.

Examination and inspection of the appliance, venting system, and all components including the burner, should be performed annually by a qualified service technician.

Examination and visual check of the burner & flame should be performed periodically to ensure proper operation. If the flame deviates greatly from the standard or if any portion of the burner has a large gap between flames, the burner orifices may need cleaning. Contact a qualified technician to diagnose, correct, and clean the burner orifices as needed.

Replacement of worn, broken, or non-functioning components should be left to a qualified service technician.

If glass panels suffer any type of impact, immediately cease use of fireplace until a qualified technician can assess the integrity of the panels and determine if they need replacement before continued use.

The area around the appliance must be kept clear and free from combustible materials, gasoline, and other flammable vapors and liquids.

Keep combustion and ventilation air flows unobstructed.

Date Issued:	Project No:	Client	Report No:	Revision No:
December 11, 2017	14563	Acucraft Fireplaces	14563-7G	0

WARRANTY

ALL WARRANTIES EFFECTIVE DATE OF SHIPMENTS

The Warranty

Acucraft warrants the gas appliance to be free from defects in materials and workmanship at the time of manufacture. On all gas appliances, there is a **lifetime warranty** on the firebox. There is a **five-year warranty** on the main burner. A **one-year warranty** is given to the pilot burner, gas control valve, glass media and logs, and other gas components.

No Warranty

Acucraft does not warrant any finish or plating on the system or any part thereof. Glass and refractory lining are exempt from warranty as well.

Remedy and Exclusions

The coverage of this warranty is limited to all components of the gas appliance manufactured by Acucraft. If the components of the gas appliance covered by this warranty are found to be defective within the time stated, Acucraft, at its option, will replace or repair defective components of the gas appliance manufactured by Acucraft at no charge, and may also choose pay for reasonable labor costs incurred in repairing components requiring approval prior to work commencing. This warranty covers only parts and labor as provided above. In no case shall Acucraft be responsible for materials, components, or construction which are not manufactured or supplied by Acucraft, or for the labor necessary to install, repair or remove such materials, components or construction. All replacement or repair components will be shipped F.O.B. back to Acucraft. A warranty credit will be issued upon receipt and testing of defective parts.

Qualifications to the Warranty

The gas appliance warranty outlined above is further subject to the following qualifications:

- (1) The gas appliance must be installed in accordance with Acucraft installation instructions and local building codes. The warranty on this Acucraft gas appliance covers only the component parts manufactured by Acucraft. The use of components manufactured by others with the Acucraft gas appliance could create serious safety hazards, and may result in the denial of certification by recognized national safety agencies, and could be in violation of local building codes. This warranty does not cover any damages occurring from the use of any components not manufactured or supplied by Acucraft.
- (2) The Acucraft gas appliance must be subjected to normal use. The gas appliances are designed to burn gas only. Burning conventional fireplace fuels such as wood, coal or any other solid fuel will cause damage to the gas appliance, will produce excessive temperatures and will result in a fire hazard.

Limitations on Liability

It is expressly agreed and understood that Acucraft's sole obligation, and purchaser's exclusive remedy under this warranty, under any other warranty, expressed or implied, or in contract, tort or otherwise, shall be limited to replacement, repair, or refund, as specified above.

In no event shall Acucraft be responsible for any incidental or consequential damages caused by defect in its products, whether such damage occurs or is discovered before or after replacement or repair, and whether or not such damage is caused by Acucraft negligence. Some states do not allow the exclusion or limitation of incidental or consequential damages, so the above limitation or exclusion may not apply to you. The duration or any implied warranty with respect to this Acucraft gas appliance is limited to the duration of the foregoing warranty. Some states do not allow limitation on how long an implied warranty lasts, so the above may not apply to you.

Investigation of Claims against Warranty

- Acucraft reserves the right to investigate any and all claims against this warranty and to decide upon method of settlement.
- Acucraft is not responsible for work done without consent.
- Acucraft shall in no event be responsible for any warranty work done without first obtaining Acucraft's written consent.
- Resellers have no authority to alter this warranty.
- Acucraft employees and resellers have no authority to make any warranties nor to authorize any remedies in addition to or inconsistent with those stated above.

How to Register a Claim against Warranty

In order for any claim under this warranty to be valid, Acucraft must be notified of the claimed defect by emailing service@acucraft.com, as soon as reasonably possible after the defect is discovered. Claims against this warranty must include the date of installation, and a description of the defect.

In order to validate your warranty you must complete the warranty form at www.acucraft.com/warranty within thirty (30) days of receiving your fireplace. Without a warranty validation you will not be able to submit any warranty claims for your Acucraft appliance.

LISTING REPORT



Date Issued:	Project No:	Client	Report No:	Revision No:
December 11, 2017	14563	Acucraft Fireplaces	14563-7G	0



SAMPLE



FIRE IS OUR PASSION

www.acucraft.com 888-317-6499

Acucraft Fireplaces
19672 172nd Street
Big Lake, MN 55309

Date Issued:	Project No:	Client	Report No:	Revision No:
December 11, 2017	14563	Acucraft Fireplaces	14563-7G	0

FACTORY PRODUCTION TESTS

FOLLOW-UP SERVICE INSPECTIONS

The LabTest Certification Inc. Field Representative shall determine that the product is manufactured in accordance with this Report, and that label procedures are followed.

Label Control - Record serial numbers of labels if applicable, in the plant. Inspect label log sheets. The following information should be recorded in the label log sheets by the manufacturer:

1. Label numbers, product labeled, date labeled or shipped, and destination.
2. Labels removed from, returned, freight damage, or rejected products should be picked up.

Examination of Product - At each Follow-up Service Inspection the LabTest Field Representative shall determine that the product which is intended to bear the LabTest Certification Mark is manufactured in accordance with the specified standards as per the test program and stated herein. The LabTest Field Representative shall pay special attention to the following:

1. Materials used must be free from defects that could affect the performance of the product.
2. Suitable protective packaging.
3. Complete Safety and Installation Instructions are supplied with each product. No modification to these instructions shall be made without LabTest authorization.

Examination of Applicant's Inspection Programs - At each Follow-up Service Inspection, the LabTest Field Representative shall determine that the Applicant's methods of inspection conform to the specifications included in the quality control procedures. The LabTest Field Representative will pay attention to:

1. The Applicant's Quality Control report is complete and conforms to the procedure accepted by LabTest and included in this Report.
2. The equipment used for inspection conforms to the specification in the quality control procedure.
3. The work area is suitable for a good quality control program.
4. Regular manufacturing production line tests are carried out by the Applicant.

Periodic unannounced Follow-up Service Inspections of the manufacturing facility shall be conducted by LabTest Certification Inc. A Follow-up Service Inspection Report shall be issued after each visit. Special attention will be given to the following:

1. Conformance of the manufactured product to the descriptions in this Report.
2. Conformance of the use of the LabTest Certification Mark with the requirements of this Report and the LabTest Certification Agreement.
3. In-plant quality control procedures and personnel.
4. Manufacturing processes and changes.
5. Performance of specified Manufacturing and Production tests.

Date Issued:	Project No:	Client	Report No:	Revision No:
December 11, 2017	14563	Acucraft Fireplaces	14563-7G	0

In the event that the LabTest representative identifies non-conformance(s) to any provision of this Report, the Applicant shall take one or more of the following actions:

- Correct the non-conformance(s).
- Remove the LabTest Certification Mark from non-conforming product.
- Contact the LabTest Certification Inc. office that issued this Report for additional instructions.

Records - Records of the use of the LabTest Certification Mark must be maintained by the Applicant and must be available for review during normal business hours.

Shipping - As practically as possible, each Listed product is to be shipped completely assembled and incorporate the necessary safety and installation instructions.

The manufacturer shall check, inspect and test the components and the assemblies, of each appliance in the following manner:

- Inspect all raw materials and purchased components.
- Test fire each burner and manifold and control assembly for proper burner and gas valve operation and verify the gas-tightness of the manifold and control assembly.
- Test each appliance to determine the electrical components, function properly. This test shall be conducted on completely assembled appliances when feasible.
When not feasible, either:
 - Subassemblies shall be tested separately; or
 - When components are to be wired in the field, written assurance from the component manufacturers that operational tests have been conducted on their devices and shall be kept on file.
- Conduct dielectric withstand tests on each factory assembled appliance incorporating high voltage electrical circuits.

NOTE: If the appliance employs solid-state components, which can be damaged by the dielectric potential, the test may be conducted before these components are electrically connected. The tests shall consist of the application of the 60-hertz potential between high-voltage current carrying parts and the casing, frame and similar non-current carrying parts of the appliance with any switch contacts both, open and closed. The test potential shall be in accordance with the dielectric withstand test specified.

Date Issued:	Project No:	Client	Report No:	Revision No:
December 11, 2017	14563	Acucraft Fireplaces	14563-7G	0

One completely assembled appliance from a weekly production batch, or one unit for every 100 units produced or whichever is more frequent of the two shall be tested to determine satisfactory operation with respect to:

- Burner Operating Characteristics
- Ignition Systems and Pilot Safety Shut-Off Devices
- Combustion
- Surface Temperatures
- Impact Test of Glazing
- Thermal Shock of Glazing
- Dielectric Withstand Tests, before Solid-State components are connected

The test methods shall be capable of relating back to the tests methods specified in the ANSI Z21.50-2016 / CSA 2.22-2016 – Vented Decorative Gas Appliances.

The results of these tests shall be recorded and maintained by manufacturer for review by LabTest Certification Inc.

Date Issued:	Project No:	Client	Report No:	Revision No:
December 11, 2017	14563	Acucraft Fireplaces	14563-7G	0

TEST DATA SECTION

The product samples listed in the following Evaluation and Test Checklists were considered representative of all model covered in this Listing Report and were tested for compliance with the standard clauses as listed below:

EVALUATION AND TEST CHECKLIST No.: 1

Project No:	14563	Product:	Indoor Vented Gas Fireplace
Model No(s):	Custom Gas L-Shaped Fireplace	Serial No:	0825
<input type="checkbox"/> Test Data Transferred from:	N/A	(Tests were conducted by an ISO 17025 accredited test lab recognized by Standard Council of Canada)	
<input checked="" type="checkbox"/> Standard used:	ANSI Z21.50-2016 / CSA 2.22-2016	(use a separate checklist for each standard)	
Testing Location:	Acucraft Fireplaces 19672 172 nd Street Big Lake, Minnesota 55309 USA	Date:	October 24, 2017

Standard Clause	Requirement / Test	Evaluation / Test Results	Verdict
5.3	Test Pressure and Burner Adjustments	The test results comply with the requirements of the standard	P
5.4	Combustion	The test results comply with the requirements of the standard	P
5.5	Appliance and Burner Durability Test	The test results comply with the requirements of the standard	P
5.6	Burner Operating Characteristics	The test results comply with the requirements of the standard	P
5.7	Loose Burner Materials	The test results comply with the requirements of the standard	P
5.8	Pilot operating Characteristics	The test results comply with the requirements of the standard	P
5.9	Pilot Burners and Safety Shut-off Devices	The test results comply with the requirements of the standard	P
5.11	Proved Igniter Systems	The test results comply with the requirements of the standard	P
5.12	Delayed Ignition and Integrity Tests for Direct Vent Gas Fireplaces	The test results comply with the requirements of the standard	P
5.13	Glass Fronts	The test results comply with the requirements of the standard	P
5.14	Burn Hazard Potential	The test results comply with the requirements of the standard	P
5.15	Impact Test of Glass Materials	The test results comply with the requirements of the standard	P
5.16	Water Shock Test	The test results comply with the requirements of the standard	P
5.17	Main Burner Temperatures	The test results comply with the requirements of the standard	P

LISTING REPORT



Date Issued:	Project No:	Client	Report No:	Revision No:
December 11, 2017	14563	Acucraft Fireplaces	14563-7G	0

5.18	Non-Load-Bearing Flue Gas Baffle Temperatures	The test results comply with the requirements of the standard	P
5.20	Gas Appliance Pressure Regulators	The test results comply with the requirements of the standard	P
5.21	Automatic Valves	The test results comply with the requirements of the standard	P
5.22	Safety Circuit Analysis	The test results comply with the requirements of the standard	P
5.23	Manifold and Control Assembly Capacity	The test results comply with the requirements of the standard	P
5.26	Wall, Floor, and Ceiling Temperatures	The test results comply with the requirements of the standard	P
5.28	Surface Temperatures	The test results comply with the requirements of the standard	P
5.29	Evaluation of Clothing Ignition Potential	The test results comply with the requirements of the standard	P
5.30	Venting	The test results comply with the requirements of the standard	P
5.32	Draft Tests for Appliances not Equipped with Draft Hoods	The test results comply with the requirements of the standard	P
5.34	Wind Tests (Sidewall Termination)	The test results comply with the requirements of the standard	P
5.35	Wind Tests (Vertical Termination)	The test results comply with the requirements of the standard	P
5.36	Vent and Vent-air Intake Terminal Assemblies	The test results comply with the requirements of the standard	P
5.37	Joints in Direct Vent Systems	The test results comply with the requirements of the standard	P
5.40	Marking Material Adhesion and Legibility	The test results comply with the requirements of the standard	P
7	Items Unique to the United States	The evaluation and test results comply with the requirements of the standard	P
8	Items Unique to Canada	The evaluation and test results comply with the requirements of the standard	P
8.1	Standard for Gas Appliances for Use at High Altitudes, CSA 2.17	The test results comply with the requirements of the standard	P
8.2	Testing Method for Measuring Annual Fireplace Efficiencies, CSA P.4.1.	The test results comply with the requirements of the standard Fireplace Efficiency: 75%	P

Date Issued:	Project No:	Client	Report No:	Revision No:
December 11, 2017	14563	Acucraft Fireplaces	14563-7G	0

UNLISTED COMPONENTS REQUIRING RE-EVALUATION-N/A

Item	Photo no:	Component	Manufacturer	Part No	Rating	Location	Frequency of re-evaluation	Sample size

END OF REPORT