

8 7 6 5 4 3 2 1

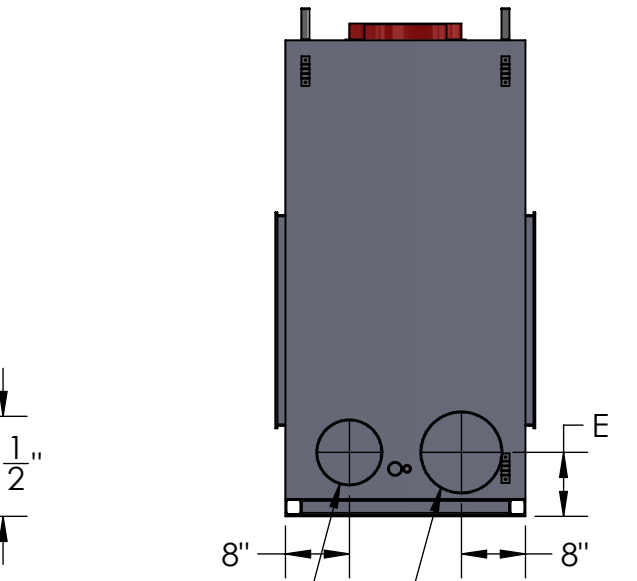
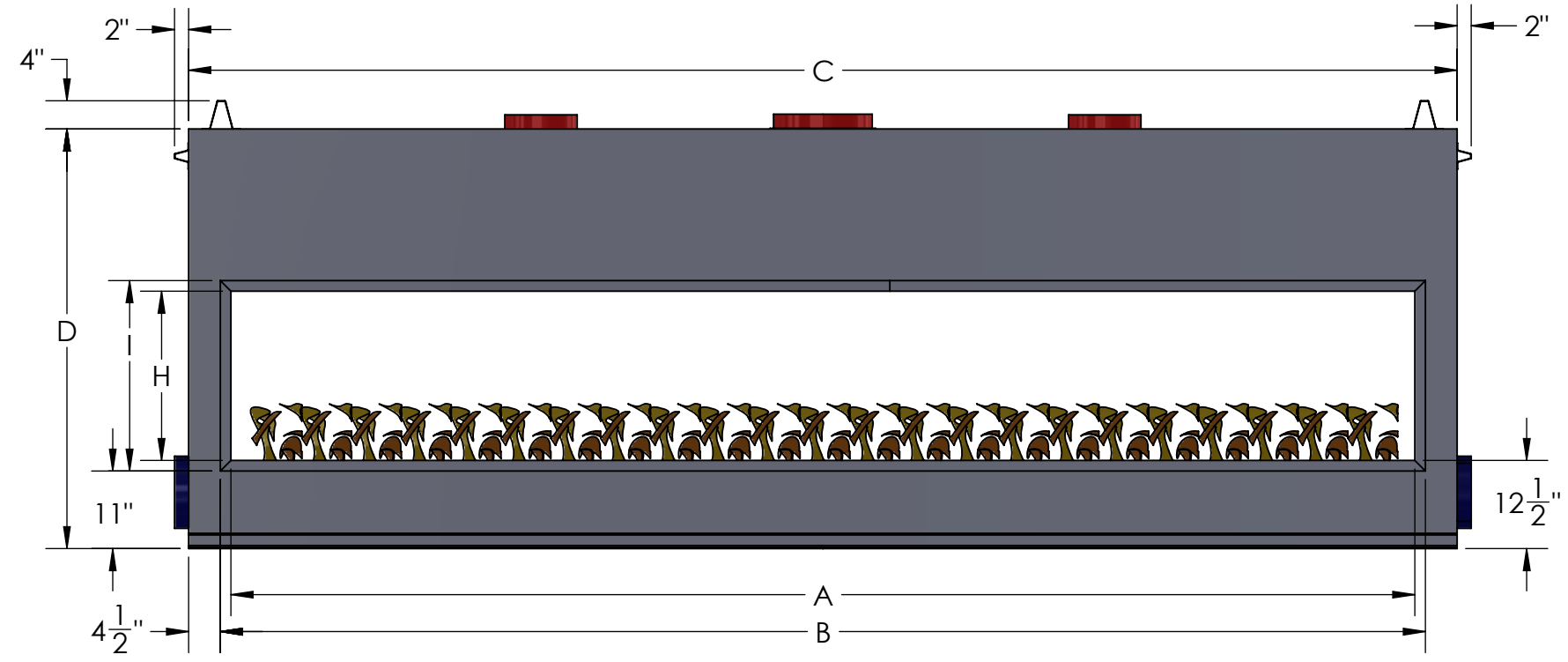
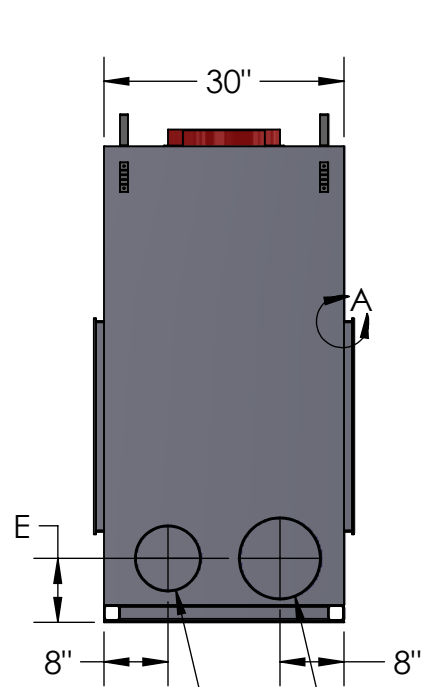
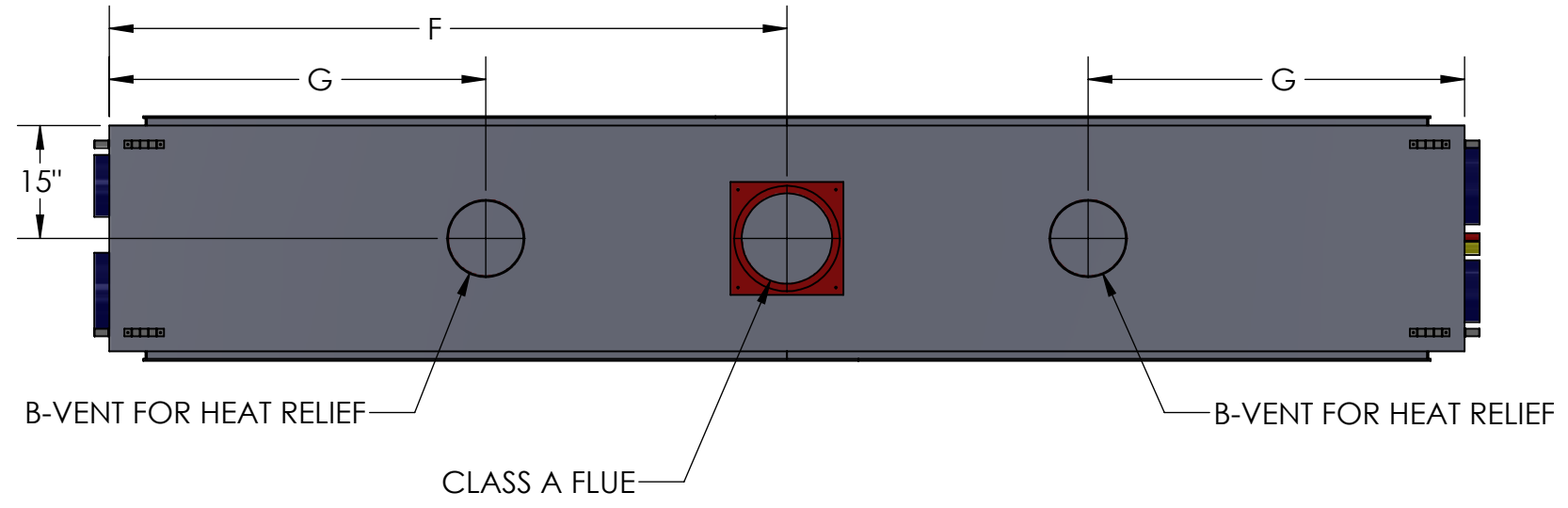
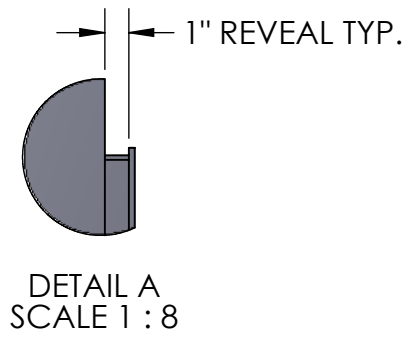

GLASS COOLING INTAKE #1

COMBUSTION AIR INTAKE #1

COMBUSTION AIR INTAKE #2

GLASS COOLING INTAKE #2

8 7 6 5 4 3 2 1

D
C
B
A

D
C
B
A