

8 7 6 5 4 3 2 1

REVISIONS			
REV.	DESCRIPTION	ECO	DATE

D  
C  
B  
A

D  
C  
B  
A

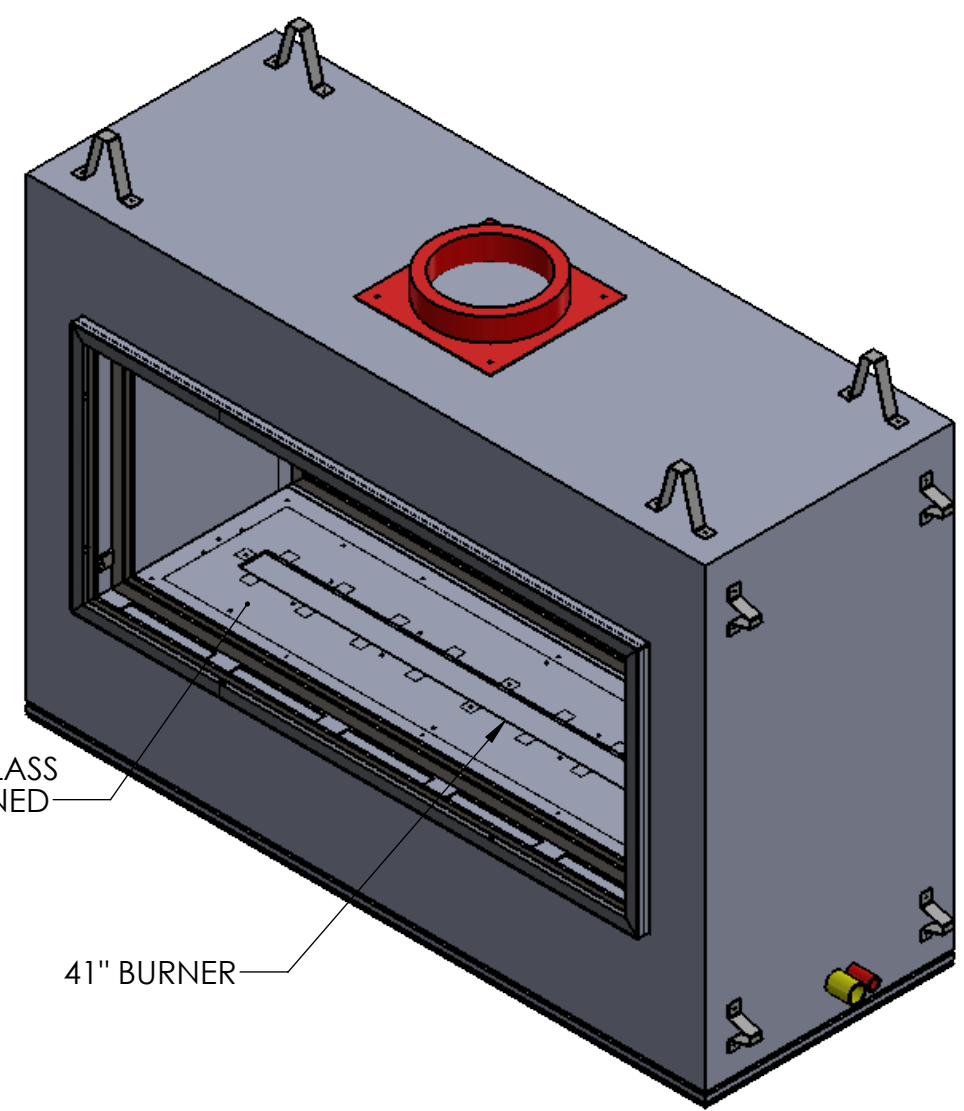

MESH TO BE COVERED WITH GLASS  
MEDIA COLOR TO BE DETERMINED

41" BURNER

- NOTES:
1. CLEARANCE TO COMBUSTIBLES TO BE 4" ON TOP AND 2" ON BACK AND SIDES
  2. FRAME AND FIREBOX TO BE FINISHED MATTE BLACK
  3. APPROXIMATE BTUS: 52,000

DO NOT SCALE DRAWING		<small>PROPRIETARY AND CONFIDENTIAL: THE INFORMATION CONTAINED IN THIS DRAWING IS THE SOLE PROPERTY OF ACUCRAFT. ANY REPRODUCTION IN PART OR AS A WHOLE WITHOUT THE WRITTEN PERMISSION OF ACUCRAFT IS PROHIBITED.</small>		 Acucraft Fireplace Systems 19672 172nd Street Big Lake, MN 55309	
UNLESS OTHERWISE SPECIFIED ALL DIMENSIONS ARE IN INCHES		TITLE: <b>SIG4 SEE THRU</b>			
DRAWN BY:	DATE:	5/23/2018			
MATERIAL:	SIZE	DWG. NO.	REV	SHEET 1 OF 2	
	<b>B</b>	<b>SIG4ST-A-002B</b>	1		

8 7 6 5 4 3 2 1

1" REVEAL



DETAIL B  
SCALE 1 : 8

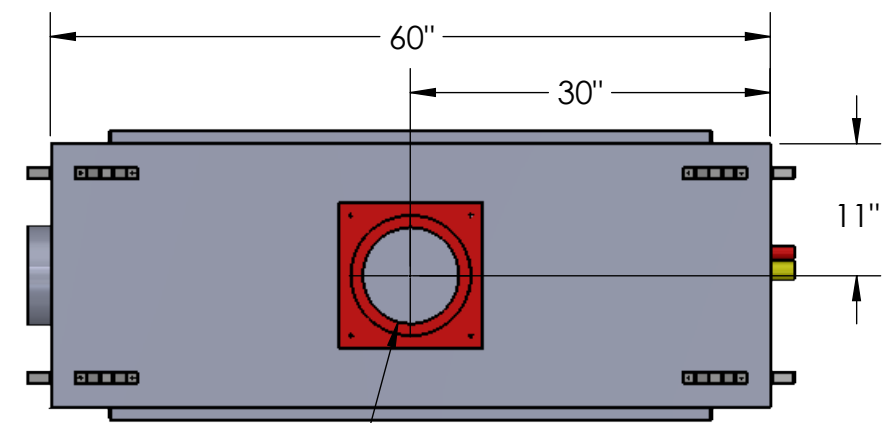

Ø 8" CLASS A FLUE

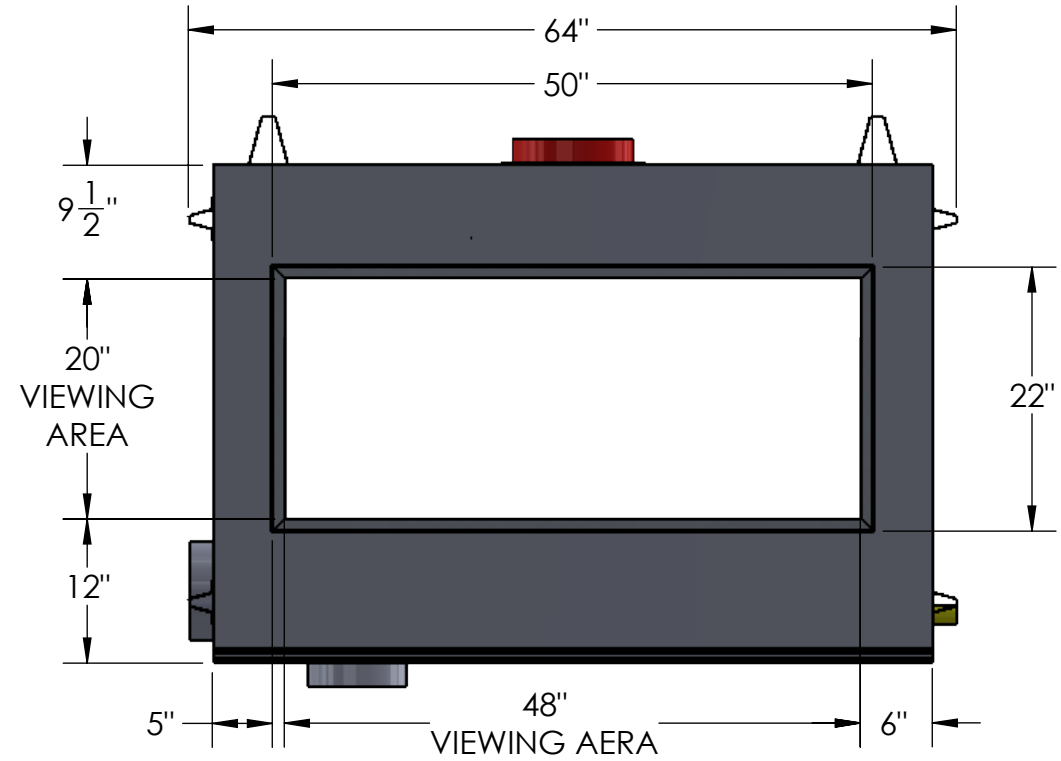

20" VIEWING AREA

48" VIEWING AREA

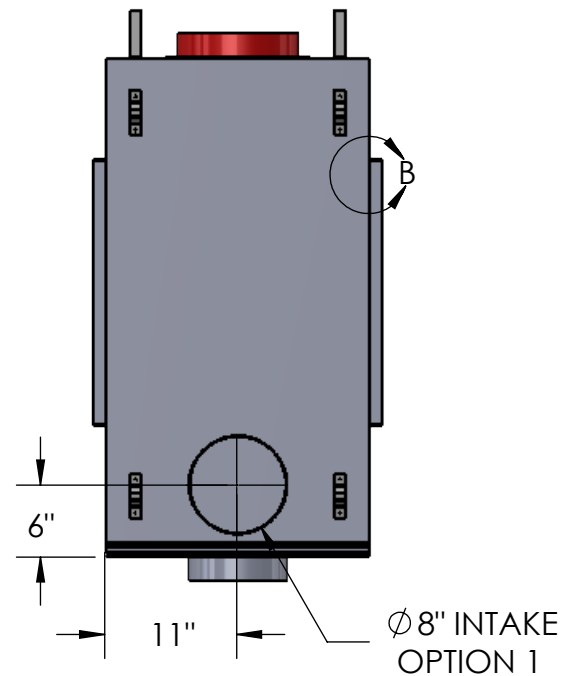

Ø 8" INTAKE  
OPTION 1

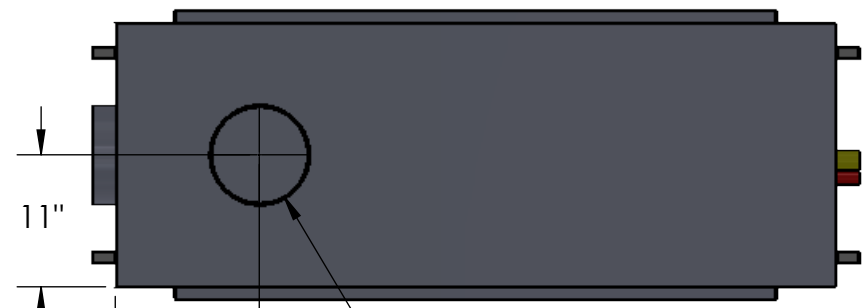

Ø 8" INTAKE  
OPTION 2

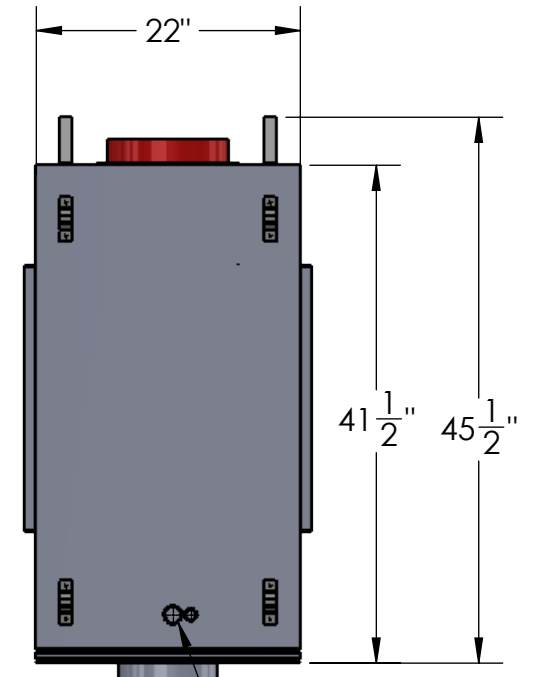

GAS AND ELECTRIC STUBS

DO NOT SCALE DRAWING		PROPRIETARY AND CONFIDENTIAL: THE INFORMATION CONTAINED IN THIS DRAWING IS THE SOLE PROPERTY OF ACUCRAFT. ANY REPRODUCTION IN PART OR AS A WHOLE WITHOUT THE WRITTEN PERMISSION OF ACUCRAFT IS PROHIBITED.		Acucraft Fireplace Systems 19672 172nd Street Big Lake, MN 55309	
UNLESS OTHERWISE SPECIFIED ALL DIMENSIONS ARE IN INCHES		TITLE: SIG4 SEE THRU			
DRAWN BY:	DATE:	5/23/2018			
MATERIAL:	SIZE	DWG. NO.	REV	SHEET 2 OF 2	
	B	SIG4ST-A-002B			